

SWING JOINTS

(FIG #1a).

- ELBOW #1 - TURNS AWAY FROM BUILDING.
- ELBOW #2 - TURNS PARALLEL TO BUILDING.
- ELBOW #3 - TURNS TOWARDS BUILDING.

(FIG #1).

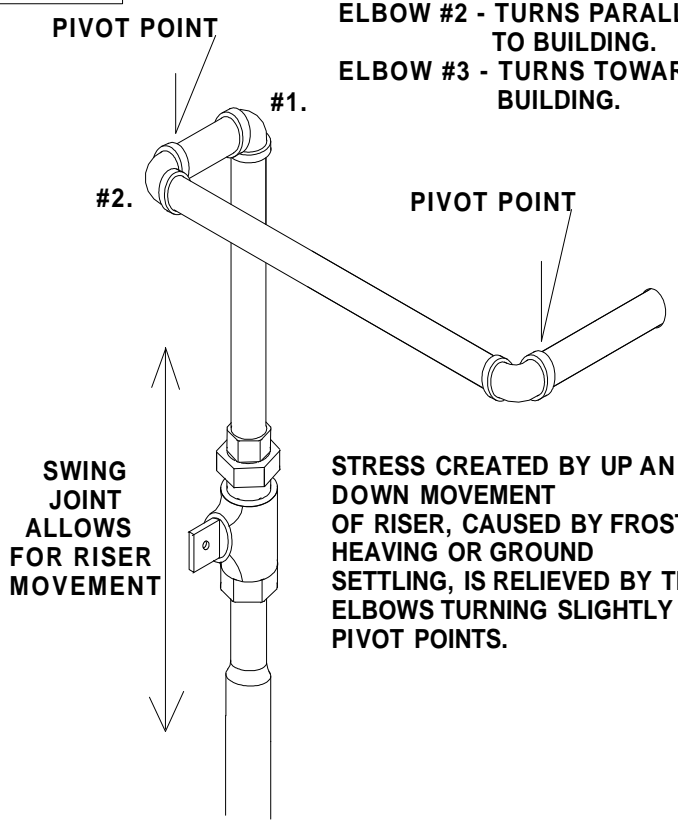
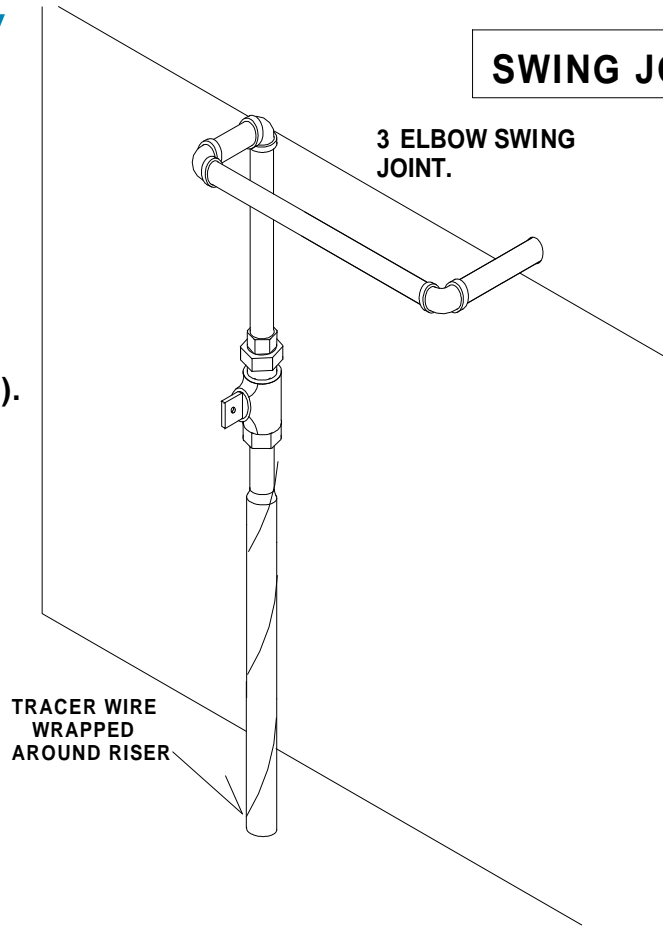

(FIG #2). COMMON MISTAKE

(FIG #3). Alternate Piping Configuration

