

CONNECT LANDSCAPE ARCHITECTURE INC. DOES NOT GUARANTEE THE EXISTENCE, LOCATION, AND ELEVATION OF UTILITIES AND / OR CONCEALED STRUCTURES AT THE PROJECT SITE.

THE CONTRACTOR IS RESPONSIBLE FOR DETERMINING THE EXISTENCE, LOCATION, AND ELEVATION OF ALL UTILITIES AND / OR CONCEALED STRUCTURES, AND IS RESPONSIBLE FOR NOTIFYING THE APPROPRIATE COMPANY, DEPARTMENT OR PERSON(S) OF ITS INTENTION TO CARRY OUT ITS OPERATIONS.

1550 EASTERN AVENUE

NORTH VANCOUVER, BC

RE-ISSUE FOR REZONING

LANDSCAPE DRAWING INDEX

DRAWING INDEX	
SHEET No.	SHEET NAME
L0.0	COVER SHEET AND DRAWING LIST
L0.1	DESIGN RATIONALE
L1.0	SITE PLAN/ LEVEL 1
L1.1	LANDSCAPE PLAN LEVEL 2
L1.2	LANDSCAPE PLAN LEVEL 4 AMENITY
L1.3	LANDSCAPE PLAN ROOF LEVEL
L1.4	LANDSCAPE OVERALL PLAN
L1.5	TREE RETENTION AND REMOVAL PLAN
L1.6	OVERALL LIGHTING PLAN
L2.0	PLANT MATERIALS AND PLANT LIST
L2.1	PLANTING PLAN LEVEL 1
L2.2	PLANTING PLAN LEVEL 2
L2.3	PLANTING PLAN LEVEL 4 AMENITY
L2.4	PLANTING PLAN ROOF LEVEL
L3.0	PRECEDENTS
L4.0	SECTIONS
L4.1	SECTIONS
L4.2	SECTIONS
L5.0	LANDSCAPE DETAILS
L5.1	LANDSCAPE DETAILS
L5.2	LANDSCAPE DETAILS
L5.3	LANDSCAPE DETAILS
L5.4	LANDSCAPE DETAILS
L5.5	LANDSCAPE DETAILS
L5.6	LANDSCAPE DETAILS

GENERAL NOTES

ALL LANDSCAPE ARCHITECTURAL DRAWINGS IN THIS PACKAGE SHALL BE READ IN CONJUNCTION WITH ALL OTHER LANDSCAPE ARCHITECTURAL DRAWINGS, DETAILS, SPECIFICATIONS, AND OTHER CORRESPONDANCE THAT MAY BE ISSUED DURING THE COURSE OF THE CONTRACT.

IF A DISCREPANCY OCCURS BETWEEN THE DRAWINGS AND THE SPECIFICATIONS OR ANY OTHER DOCUMENT ASSOCIATED WITH THE PROJECT, THE CONFLICT SHALL BE REPORTED IN WRITING TO THE LANDSCAPE ARCHITECT TO OBTAIN CLARIFICATION AND APPROVAL BEFORE PROCEEDING WITH WORKS.

THE CONTRACTOR SHALL VISIT THE SITE TO VERIFY THE TRUE EXISTING CONDITIONS. ANY UNCLEAR ISSUES SHALL BE CLARIFIED WITH THE LANDSCAPE ARCHITECT. NO CLAIM SHALL BE ALLOWED FOR EXTRAS WHICH MAY ARISE THROUGH NEGLIGENCE OF THIS ADVICE.

ALL EXISTING INFORMATION IS BASED ON AVAILABLE RECORDS AND SHALL NOT BE CONSTRUED TO BE COMPLETE OR ACCURATE.

LAYOUT OF HARDSCAPE, SITE FURNITURE, SOIL, PLANTING, AND ALL OTHER MATERIALS IS TO BE STAKED OUT AND APPROVED BY THE LANDSCAPE ARCHITECT PRIOR TO INSTALLATION.

ALL PLANTING SHALL BE IN ACCORDANCE WITH CANADIAN LANDSCAPE STANDARD, LATEST EDITION.

ALL LANDSCAPE AREAS TO BE IRRIGATED WITH HIGH EFFICIENCY IRRIGATION SYSTEM.

THE CONTRACTOR IS RESPONSIBLE FOR DETERMINING THE EXISTENCE, LOCATION, AND ELEVATION OF ALL UTILITIES AND CONCEALED STRUCTURES, AND IS RESPONSIBLE FOR NOTIFYING THE APPROPRIATE COMPANY, DEPARTMENT OR PERSON(S) OF ITS INTENTION TO CARRY OUT ITS OPERATIONS.

CONNECT LANDSCAPE ARCHITECTURE INC. DOES NOT GUARANTEE THE EXISTENCE, LOCATION, AND ELEVATION OF UTILITIES OR CONCEALED STRUCTURES AT THE PROJECT SITE.

FINAL SELECTION AND APPROVAL OF ALL STREET TREES TO BE DONE BY THE CITY OF NORTH VANCOUVER.

PROJECT INFORMATION

ARCHITECT:
 RAFII ARCHITECTS INC.
 CONTACT NAME: FOAD RAFII
 1600 HOWE STREET, VANCOUVER, BC, V6Z 2L9
 EMAIL: FOAD@RAFIIARCHITECTS.COM
 PH: (604) 688-3655

LANDSCAPE ARCHITECT:
 CONNECT LANDSCAPE ARCHITECTURE
 CONTACT NAME: MARINA ROMMEL/ KEN LARSSON
 2305 HEMLOCK STREET
 VANCOUVER, BC, V6H 2V1
 EMAIL: MARINA@CONNECTLA.CA
 PH: (604) 681-3303 EXT 223

13	RE-ISSUED FOR REZONING	22-07-19
12	RE-ISSUED FOR REZONING	22-02-23
11	RE-ISSUED FOR REZONING	22-01-19
10	ISSUED FOR VCH REVIEW	21-12-22
9	ISSUED FOR VCH REVIEW	21-09-08
8	ISSUED FOR ADP	21-07-14
7	ISSUED FOR VCH REVIEW	21-05-26
6	ISSUED FOR VCH REVIEW	21-03-26
5	ISSUED FOR REZONING	20-10-14
4	ISSUED FOR VCH REVIEW	20-10-07
3	ISSUED FOR REVIEW	20-09-18
2	ISSUED FOR REVIEW	20-07-10
1	ISSUED FOR REVIEW	20-06-29

REVISIONS

1550-EASTERN AVENUE

1550- Eastern Ave
 North Vancouver, BC

Scale:	AS SHOWN
Drawn:	MR
Reviewed:	KL
Project No.	06-705

COVER SHEET

CONNECT LANDSCAPE ARCHITECTURE INC. DOES NOT GUARANTEE THE EXISTENCE, LOCATION, AND ELEVATION OF UTILITIES AND / OR CONCEALED STRUCTURES AT THE PROJECT SITE.

THE CONTRACTOR IS RESPONSIBLE FOR DETERMINING THE EXISTENCE, LOCATION, AND ELEVATION OF ALL UTILITIES AND / OR CONCEALED STRUCTURES, AND IS RESPONSIBLE FOR NOTIFYING THE APPROPRIATE COMPANY, DEPARTMENT OR PERSON(S) OF ITS INTENTION TO CARRY OUT ITS OPERATIONS.

13	RE-ISSUED FOR REZONING	22-07-19
12	RE-ISSUED FOR REZONING	22-02-23
11	RE-ISSUED FOR REZONING	22-01-19
10	ISSUED FOR VCH REVIEW	21-12-22
9	ISSUED FOR VCH REVIEW	21-09-08
8	ISSUED FOR ADP	21-07-14
7	ISSUED FOR VCH REVIEW	21-05-26
6	ISSUED FOR VCH REVIEW	21-03-26
5	ISSUED FOR REZONING	20-10-14
4	ISSUED FOR VCH REVIEW	20-10-07
3	ISSUED FOR REVIEW	20-09-18
2	ISSUED FOR REVIEW	20-07-10
1	ISSUED FOR REVIEW	20-06-29
REVISIONS		GROUND LEVEL

DESIGN RATIONALE AND PRINCIPALS



WELCOMING BUILDING

Building entries have been designed to provide comfortable sheltered seating areas that promote social interaction and activate the street.

Layered Westcoast planting and materials reinforce the place identity of the North Shore.

Boulevard improvements and new street trees, as well as new lane sidewalks and street level patios with planters facing the lane, create a friendly improved street face.



PLACE IDENTITY

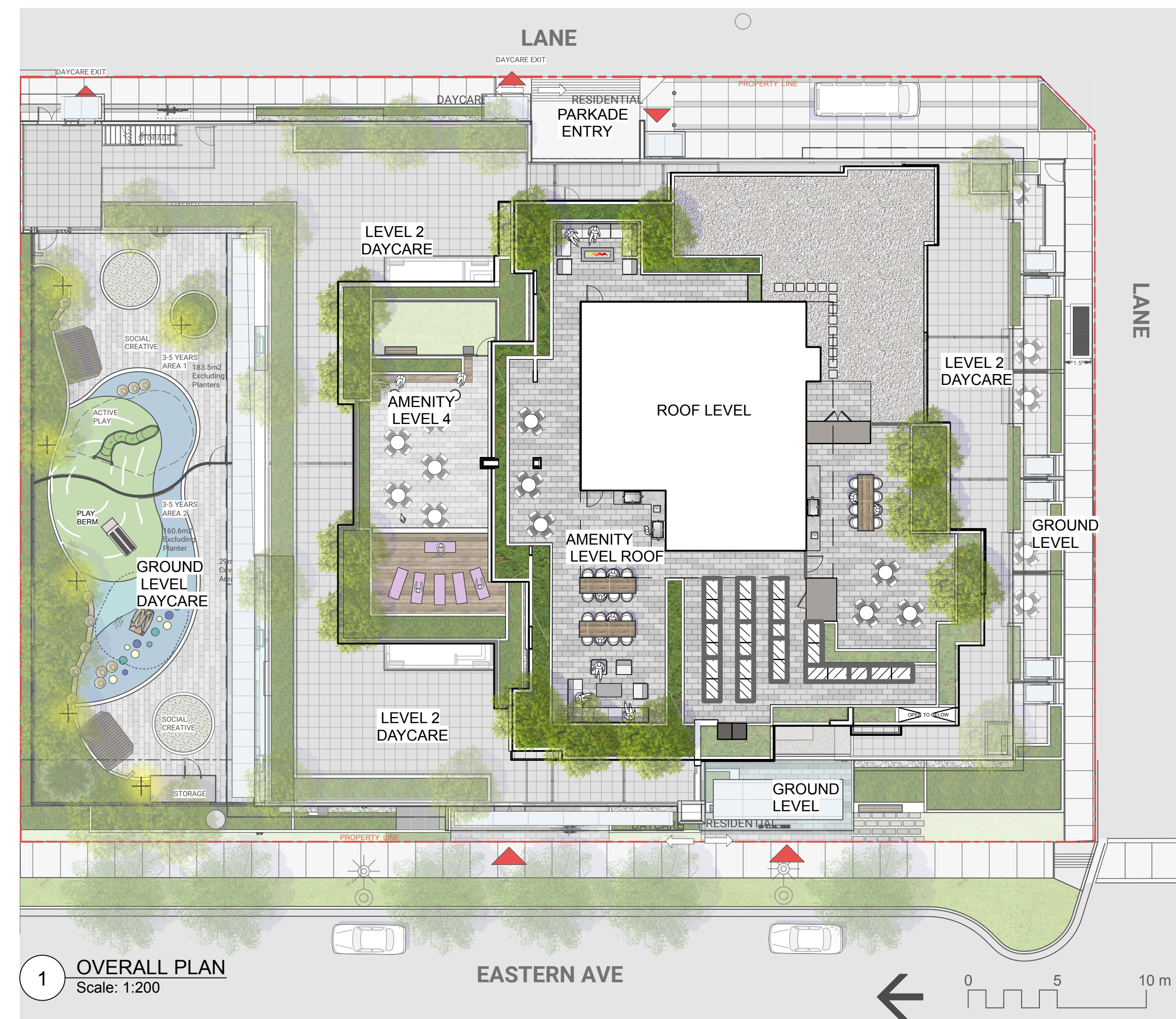

AMENITY SPACES FOR EVERYONE

Multiple daycare groups occupy the ground level and the second level outdoor space providing much needed child care spaces to the community.

The communal amenity deck on level 4 offers residents a wide variety of outdoor spaces.

A fenced pet retreat area, provides space for dogs and their owners. A terrace with movable seating and raised deck for exercise and lounging with views to the future park and nature promote a healthy lifestyle.

The sunny roof deck amenity adjacent to the indoor amenity features a family BBQ and dining area to the N-W and an adult BBQ and dining area to the S-W. Urban agriculture planter area to the south provides residents with the opportunity to grow their own food and connect to nature. A lounge seating area with fire place to the East adds to the social communal program of the terrace.



SPACES FOR EVERYONE



















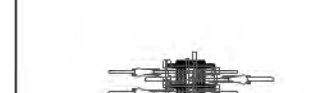

1550-EASTERN AVENUE

1550- Eastern Ave
North Vancouver, BC

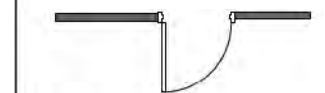
Scale:	AS SHOWN
Drawn:	MR
Reviewed:	KL
Project No.	06-705

DESIGN RATIONALE

MATERIALS LEGEND

-  PROPOSED TREES
-  PLANTING AREA
-  LAWN AREA
-  UNIT PAVING
-  2'x1' ARCHITECTURAL SLABS
-  2'x2' ARCHITECTURAL SLABS
-  CIP CONCRETE PAVING
-  TIMBER DECKING
-  POURED IN PLACE RUBBER PLAY FALL SURFACE
-  ROUND DRAIN ROCK
-  BIKE RACK (6 CLASS B STALLS EA)
-  CONCRETE SEAT WALL W/ BENCH TOP
-  3' METAL FENCE AND GATE AT DAYCARE
-  6' TIMBER FENCE AND WALL
-  3' DIVIDER FENCE
-  4' METAL FENCE AND GATE
-  TRAFFIC BOLLARD
-  LIGHT BOLLARD
-  BUILDING ENTRY

NOTES:
ALL OFFSITE BOULEVARD AND TREES TO BE IRRIGATED TO CNV STANDARDS. IRRIGATION PLANS TO BE PROVIDED AT BP.



CONNECT LANDSCAPE ARCHITECTURE INC. DOES NOT GUARANTEE THE EXISTENCE, LOCATION, AND ELEVATION OF UTILITIES AND / OR CONCEALED STRUCTURES AT THE PROJECT SITE.

THE CONTRACTOR IS RESPONSIBLE FOR DETERMINING THE EXISTENCE, LOCATION, AND ELEVATION OF ALL UTILITIES AND / OR CONCEALED STRUCTURES, AND IS RESPONSIBLE FOR NOTIFYING THE APPROPRIATE COMPANY, DEPARTMENT OR PERSON(S) OF ITS INTENTION TO CARRY OUT ITS OPERATIONS.

13	RE-ISSUED FOR REZONING	22-07-19
12	RE-ISSUED FOR REZONING	22-02-23
11	RE-ISSUED FOR REZONING	22-01-19
10	ISSUED FOR VCH REVIEW	21-12-22
9	ISSUED FOR VCH REVIEW	21-09-08
8	ISSUED FOR ADP	21-07-14
7	ISSUED FOR VCH REVIEW	21-05-26
6	ISSUED FOR VCH REVIEW	21-03-26
5	ISSUED FOR REZONING	20-10-14
4	ISSUED FOR VCH REVIEW	20-10-07
3	ISSUED FOR REVIEW	20-09-18
2	ISSUED FOR REVIEW	20-07-10
1	ISSUED FOR REVIEW	20-06-29

REVISIONS

1550-EASTERN AVENUE

1550- Eastern Ave
North Vancouver, BC

Scale: 1:100
Drawn: MR
Reviewed: KL
Project No. 06-705

CONNECT LANDSCAPE ARCHITECTURE INC.
DOES NOT GUARANTEE THE EXISTENCE,
LOCATION, AND ELEVATION OF UTILITIES AND /
OR CONCEALED STRUCTURES AT THE PROJECT
SITE.

THE CONTRACTOR IS RESPONSIBLE FOR
DETERMINING THE EXISTENCE, LOCATION, AND
ELEVATION OF ALL UTILITIES AND / OR
CONCEALED STRUCTURES, AND IS
RESPONSIBLE FOR NOTIFYING THE
APPROPRIATE COMPANY, DEPARTMENT OR
PERSON(S) OF ITS INTENTION TO CARRY OUT ITS
OPERATIONS.



13	RE-ISSUED FOR REZONING	22-07-19
12	RE-ISSUED FOR REZONING	22-02-23
11	RE-ISSUED FOR REZONING	22-01-19
10	ISSUED FOR VCH REVIEW	21-12-22
9	ISSUED FOR VCH REVIEW	21-09-08
8	ISSUED FOR ADP	21-07-14
7	ISSUED FOR VCH REVIEW	21-05-26
6	ISSUED FOR VCH REVIEW	21-03-26
5	ISSUED FOR REZONING	20-10-14
4	ISSUED FOR VCH REVIEW	20-10-07
3	ISSUED FOR REVIEW	20-09-18
2	ISSUED FOR REVIEW	20-07-10
1	ISSUED FOR REVIEW	20-06-29

REVISIONS

1550-EASTERN AVENUE

1550- Eastern Ave
North Vancouver, BC







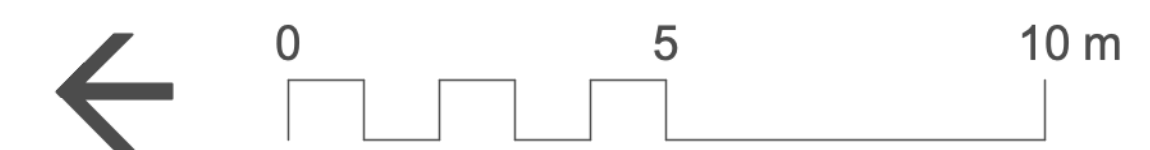

Scale:	1:100
Drawn:	MR
Reviewed:	KL
Project No.	06-705

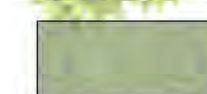
**LEVEL 2
LANDSCAPE PLAN**

1 LEVEL 2 LANDSCAPE PLAN
Scale: 1:100

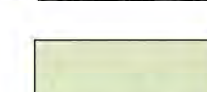

MATERIALS LEGEND LEVEL 4

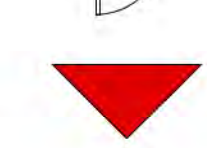
-  PROPOSED TREES
-  PLANTING AREA
-  UNIT PAVING
-  2'x2' ARCHITECTURAL SLABS
-  TIMBER DECKING
-  ROUND DRAIN ROCK
-  ARTIFICIAL TURF DOG RETREAT AREA
-  DOG WASTE STATION
-  BENCH
-  METAL FENCE AND GATE
-  BUILDING ENTRY

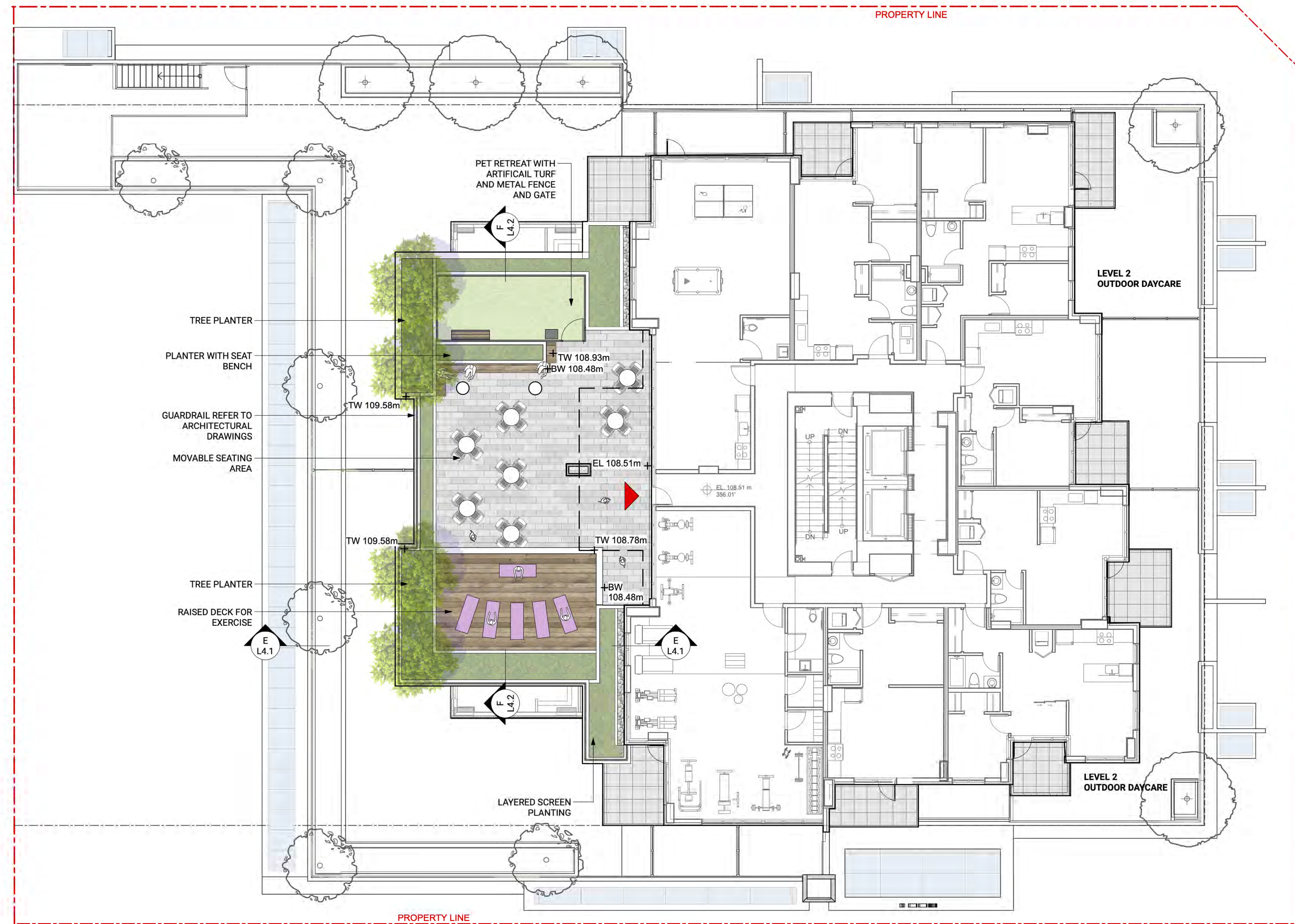

1 LEVEL 4 LANDSCAPE PLAN
Scale: 1:100

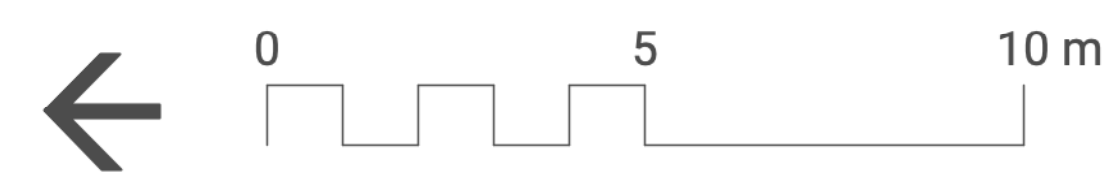

CONNECT LANDSCAPE ARCHITECTURE INC. DOES NOT GUARANTEE THE EXISTENCE, LOCATION, AND ELEVATION OF UTILITIES AND / OR CONCEALED STRUCTURES AT THE PROJECT SITE.

THE CONTRACTOR IS RESPONSIBLE FOR DETERMINING THE EXISTENCE, LOCATION, AND ELEVATION OF ALL UTILITIES AND / OR CONCEALED STRUCTURES, AND IS RESPONSIBLE FOR NOTIFYING THE APPROPRIATE COMPANY, DEPARTMENT OR PERSON(S) OF ITS INTENTION TO CARRY OUT ITS OPERATIONS.

13	RE-ISSUED FOR REZONING	22-07-19
12	RE-ISSUED FOR REZONING	22-02-23
11	RE-ISSUED FOR REZONING	22-01-19
10	ISSUED FOR VCH REVIEW	21-12-22
9	ISSUED FOR VCH REVIEW	21-09-08
8	ISSUED FOR ADP	21-07-14
7	ISSUED FOR VCH REVIEW	21-05-26
6	ISSUED FOR VCH REVIEW	21-03-26
5	ISSUED FOR REZONING	20-10-14
4	ISSUED FOR VCH REVIEW	20-10-07
3	ISSUED FOR REVIEW	20-09-18
2	ISSUED FOR REVIEW	20-07-10
1	ISSUED FOR REVIEW	20-06-29

REVISIONS

1550-EASTERN AVENUE

1550- Eastern Ave
North Vancouver, BC

Scale:	1:100
Drawn:	MR
Reviewed:	KL
Project No.	06-705

LEVEL 4 LANDSCAPE PLAN

CONNECT LANDSCAPE ARCHITECTURE INC. DOES NOT GUARANTEE THE EXISTENCE, LOCATION, AND ELEVATION OF UTILITIES AND / OR CONCEALED STRUCTURES AT THE PROJECT SITE.

THE CONTRACTOR IS RESPONSIBLE FOR DETERMINING THE EXISTENCE, LOCATION, AND ELEVATION OF ALL UTILITIES AND / OR CONCEALED STRUCTURES, AND IS RESPONSIBLE FOR NOTIFYING THE APPROPRIATE COMPANY, DEPARTMENT OR PERSON(S) OF ITS INTENTION TO CARRY OUT ITS OPERATIONS.

13	RE-ISSUED FOR REZONING	22-07-19
12	RE-ISSUED FOR REZONING	22-02-23
11	RE-ISSUED FOR REZONING	22-01-19
10	ISSUED FOR VCH REVIEW	21-12-22
9	ISSUED FOR VCH REVIEW	21-09-08
8	ISSUED FOR ADP	21-07-14
7	ISSUED FOR VCH REVIEW	21-05-26
6	ISSUED FOR VCH REVIEW	21-03-26
5	ISSUED FOR REZONING	20-10-14
4	ISSUED FOR VCH REVIEW	20-10-07
3	ISSUED FOR REVIEW	20-09-18
2	ISSUED FOR REVIEW	20-07-10
1	ISSUED FOR REVIEW	20-06-29

REVISIONS

1550-EASTERN AVENUE











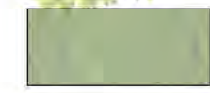

1550- Eastern Ave
North Vancouver, BC

Scale:	1:100
Drawn:	MR
Reviewed:	KL
Project No.	06-705

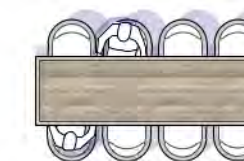
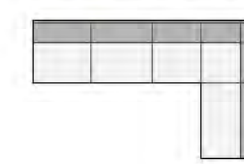
ROOF LEVEL LANDSCAPE PLAN

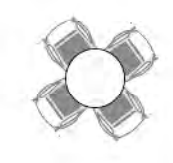
L1.3

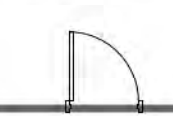
MATERIALS LEGEND ROOF

-  PROPOSED TREES
-  PLANTING AREA
-  RAISED METAL PLANTER (URBAN AGRICULTURE)
-  CIP CONCRETE PLANTER
-  ROOF BALLAST ROCK
-  2x1' ARCHITECTURAL SLABS NATURAL, CHARCOAL MIX
-  18" SQ ARCHITECTURAL SLABS, CHARCOAL
-  BBQ COUNTER & SINK
-  TABLE AND CHAIRS
-  LOUNGE AREA
-  GAS FIRE TABLE
-  MOVABLE TABLE AND CHAIRS BY OWNER
-  GREEN BIN & STORAGE HOSE BIB LOCATION FOR URBAN AGRICULTURE
-  6' METAL DIVIDER FENCE AND GATE
-  BUILDING ENTRY

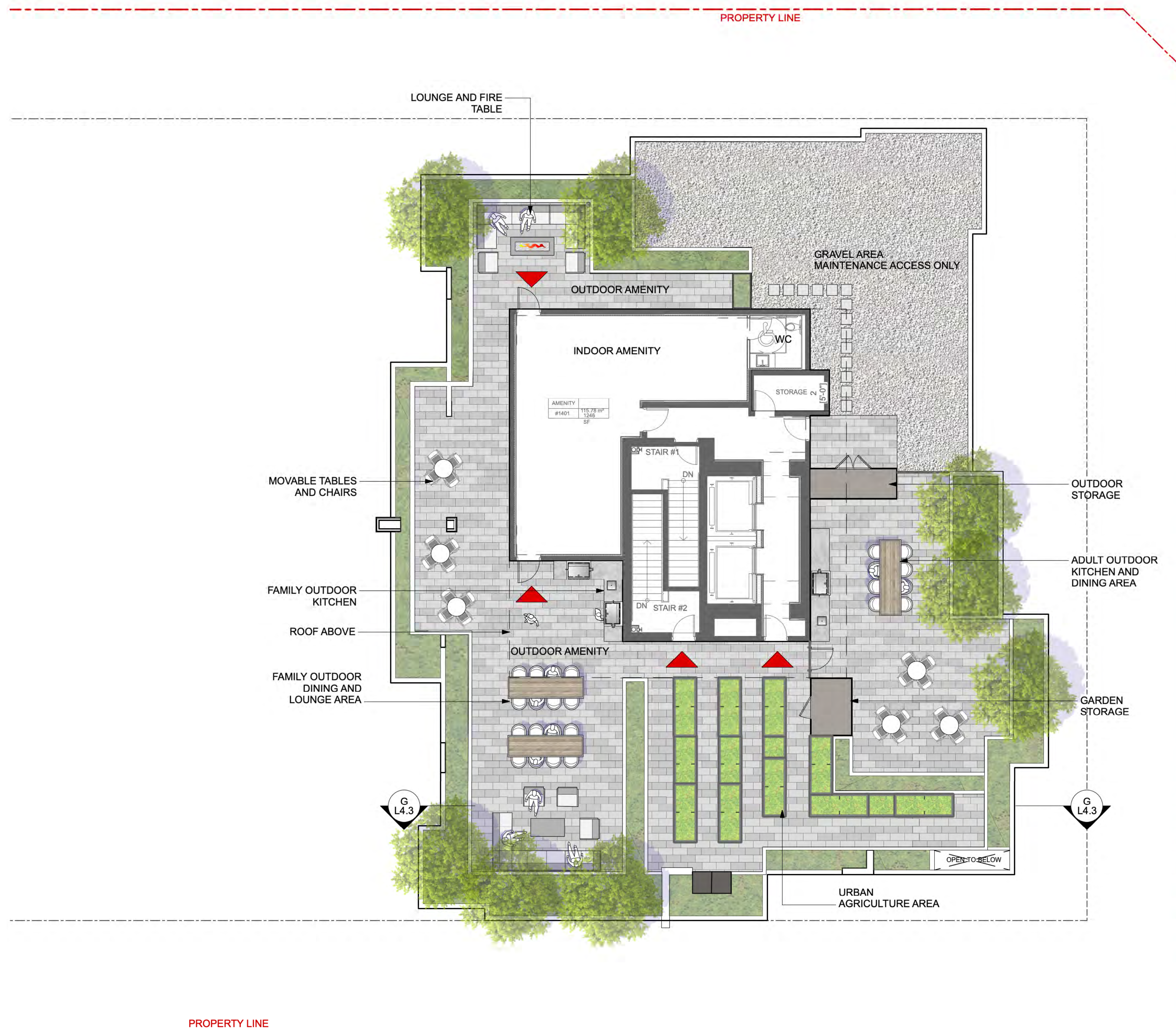

1 ROOF PLAN
Scale: 1:100

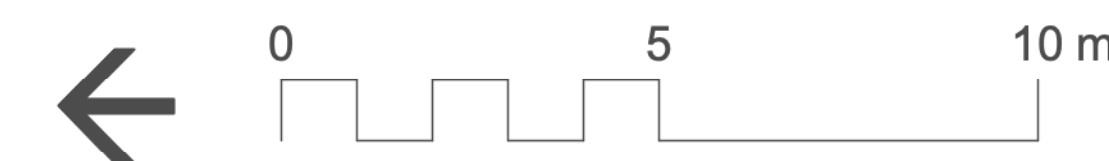

CONNECT LANDSCAPE ARCHITECTURE INC. DOES NOT GUARANTEE THE EXISTENCE, LOCATION, AND ELEVATION OF UTILITIES AND / OR CONCEALED STRUCTURES AT THE PROJECT SITE.

THE CONTRACTOR IS RESPONSIBLE FOR DETERMINING THE EXISTENCE, LOCATION, AND ELEVATION OF ALL UTILITIES AND / OR CONCEALED STRUCTURES, AND IS RESPONSIBLE FOR NOTIFYING THE APPROPRIATE COMPANY, DEPARTMENT OR PERSON(S) OF ITS INTENTION TO CARRY OUT ITS OPERATIONS.

13	RE-ISSUED FOR REZONING	22-07-19
12	RE-ISSUED FOR REZONING	22-02-23
11	RE-ISSUED FOR REZONING	22-01-19
10	ISSUED FOR VCH REVIEW	21-12-22
9	ISSUED FOR VCH REVIEW	21-09-08
8	ISSUED FOR ADP	21-07-14
7	ISSUED FOR VCH REVIEW	21-05-26
6	ISSUED FOR VCH REVIEW	21-03-26
5	ISSUED FOR REZONING	20-10-14
4	ISSUED FOR VCH REVIEW	20-10-07
3	ISSUED FOR REVIEW	20-09-18
2	ISSUED FOR REVIEW	20-07-10
1	ISSUED FOR REVIEW	20-06-29

REVISIONS

1550-EASTERN AVENUE

1550- Eastern Ave
North Vancouver, BC

Scale:	1:100
Drawn:	MR
Reviewed:	KL
Project No.	06-705

OVERALL LANDSCAPE PLAN

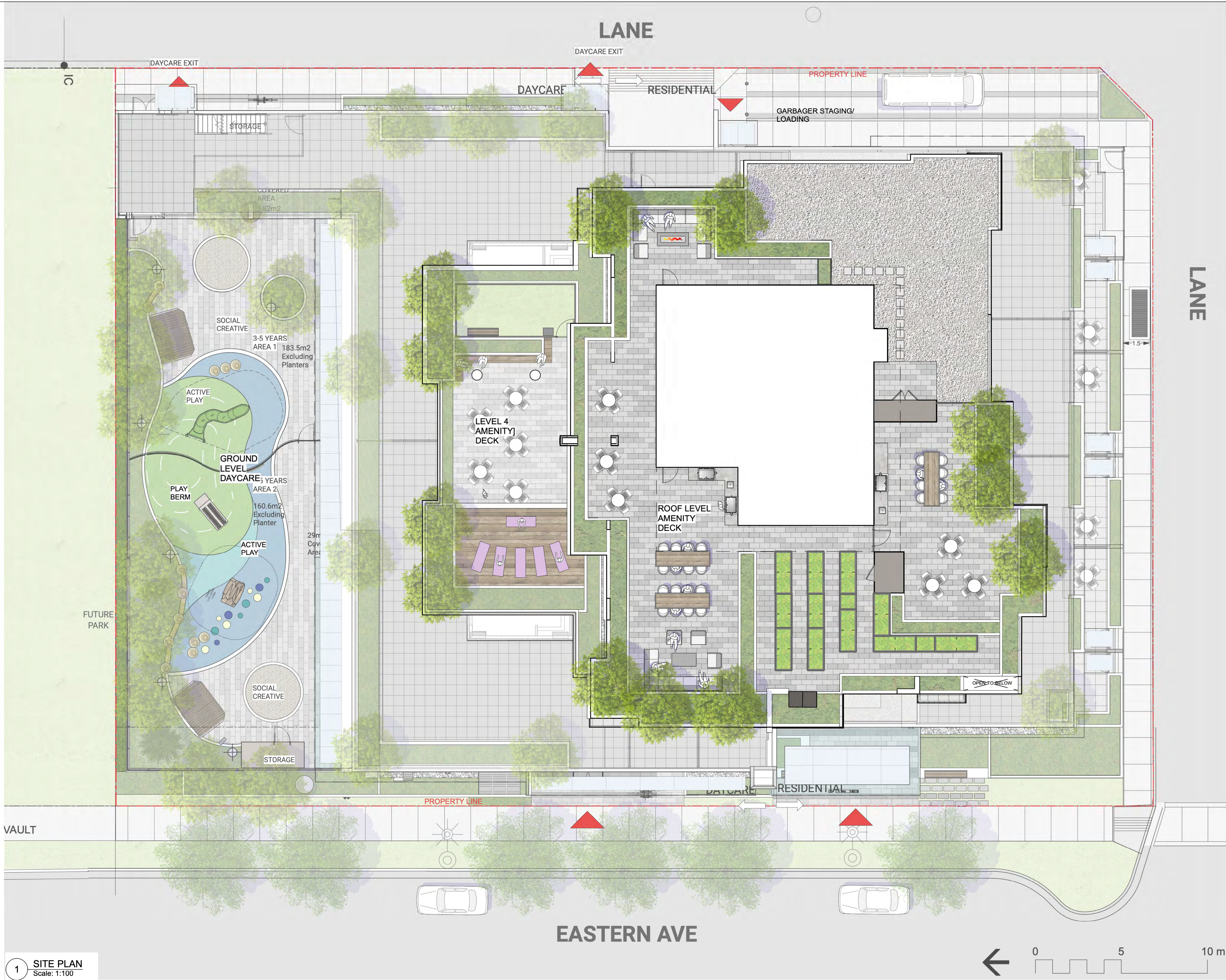

1 SITE PLAN
Scale: 1:100

CONNECT LANDSCAPE ARCHITECTURE INC. DOES NOT GUARANTEE THE EXISTENCE, LOCATION, AND ELEVATION OF UTILITIES AND / OR CONCEALED STRUCTURES AT THE PROJECT SITE.

THE CONTRACTOR IS RESPONSIBLE FOR DETERMINING THE EXISTENCE, LOCATION, AND ELEVATION OF ALL UTILITIES AND / OR CONCEALED STRUCTURES, AND IS RESPONSIBLE FOR NOTIFYING THE APPROPRIATE COMPANY, DEPARTMENT OR PERSON(S) OF ITS INTENTION TO CARRY OUT ITS OPERATIONS.

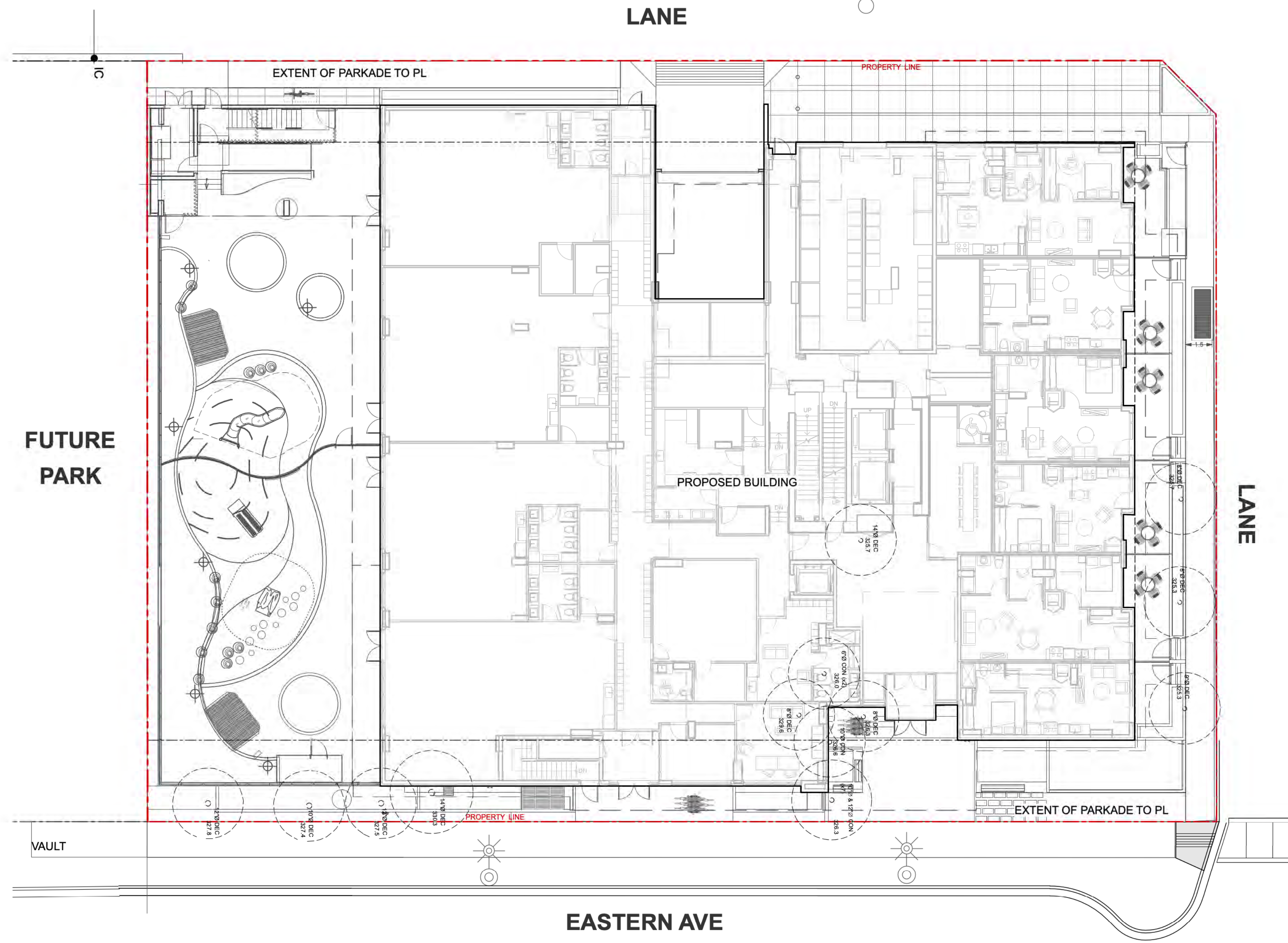

1 SITE PLAN
Scale: 1:150

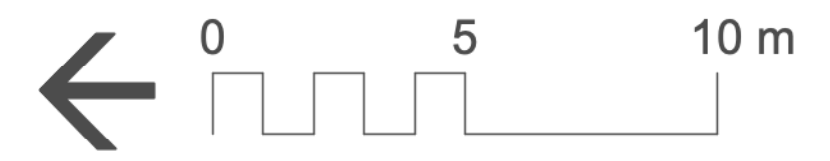

TREE RETENTION LEGEND
DESCRIPTION

EXISTING TREE TO BE RETAINED

EXISTING TREE TO BE REMOVED

SYMBOL

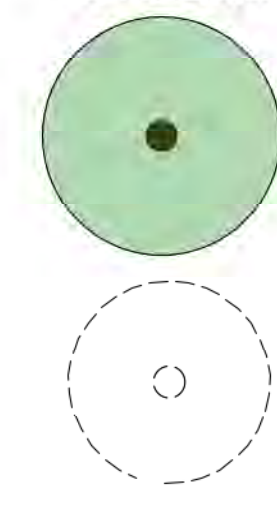

TREE RETENTION NOTES

1. REFER ALSO TO SURVEY DRAWINGS. ANY EXISTING TREES NOT IDENTIFIED ON DRAWINGS ARE TO BE PROTECTED UNTIL CONSULTANTS CAN REVIEW AND DETERMINE THE CIRCUMSTANCES.
2. WHERE REQUIRED INSTALL TREE PROTECTION BARRIER AROUND ALL TREES TO BE PRESERVED TO CITY OF NORTH VANCOUVER STANDARDS AND SPECIFICATIONS. INFORM LANDSCAPE ARCHITECT WHEN ALL TREE BARRIERS HAVE BEEN INSTALLED. ARBORIST TO PROVIDE WRITTEN INSPECTION AND APPROVAL OF ALL BARRIERS PRIOR TO CONSTRUCTION ACTIVITY.
3. DO NOT REMOVE OR RELOCATE ANY TREE. ALL RETAINED TREES ARE TO BE PRUNED AND PROTECTED BY CITY OF NORTH VANCOUVER TREE PROTECTION BY-LAWS. CONTRACTOR TO CONTACT CITY ARBORIST AND LANDSCAPE ARCHITECT 48 HOURS PRIOR TO ANY CONSTRUCTION WORK AFFECTING THE DRIP LINE OF TREES.
4. DO NOT ALTER EXISTING GRADE OR STORE MATERIALS UNDER THE DRIP LINE OR WITHIN TREE PROTECTION ZONE. EXCAVATION WITHIN DRIP LINES OF TREES IS NOT PERMISSABLE. TUNNEL UNDER AND AROUND ALL SIGNIFICANT ROOTS BY HAND DIGGING OR AIR SPADE. DO NOT CUT MAIN LATERAL ROOTS. FOR CARE AND PROTECTION OF ROOT CURTAIN SYSTEM, SEE IFC SPECIFICATIONS. TRENCHING FOR UTILITY CONNECTIONS TO BE COORDINATED WITH ENGINEERING DEPARTMENT TO ENSURE SAFE ROOT ZONES OF RETAINED TREES.

13	RE-ISSUED FOR REZONING	22-07-19
12	RE-ISSUED FOR REZONING	22-02-23
11	RE-ISSUED FOR REZONING	22-01-19
10	ISSUED FOR VCH REVIEW	21-12-22
9	ISSUED FOR VCH REVIEW	21-09-08
8	ISSUED FOR ADP	21-07-14
7	ISSUED FOR VCH REVIEW	21-05-26
6	ISSUED FOR VCH REVIEW	21-03-26
5	ISSUED FOR REZONING	20-10-14
4	ISSUED FOR VCH REVIEW	20-10-07
3	ISSUED FOR REVIEW	20-09-18
2	ISSUED FOR REVIEW	20-07-10
1	ISSUED FOR REVIEW	20-06-29

REVISIONS

1550-EASTERN AVENUE

1550- Eastern Ave
North Vancouver, BC

Scale:	1:150
Drawn:	MR
Reviewed:	KL
Project No.	06-705

TREE REMOVAL AND RETENTION PLAN

LIGHTING LEGEND

DESCRIPTION	SYMBOL
BOLLARD LIGHT	
WALL STEP LIGHT	
LED LIGHT STRIP RECESSED UNDER BENCH	
CANOPY LIGHT	
BUILDING ENTRY LIGHTING BY ARCHITECTS	
STREET LIGHT	

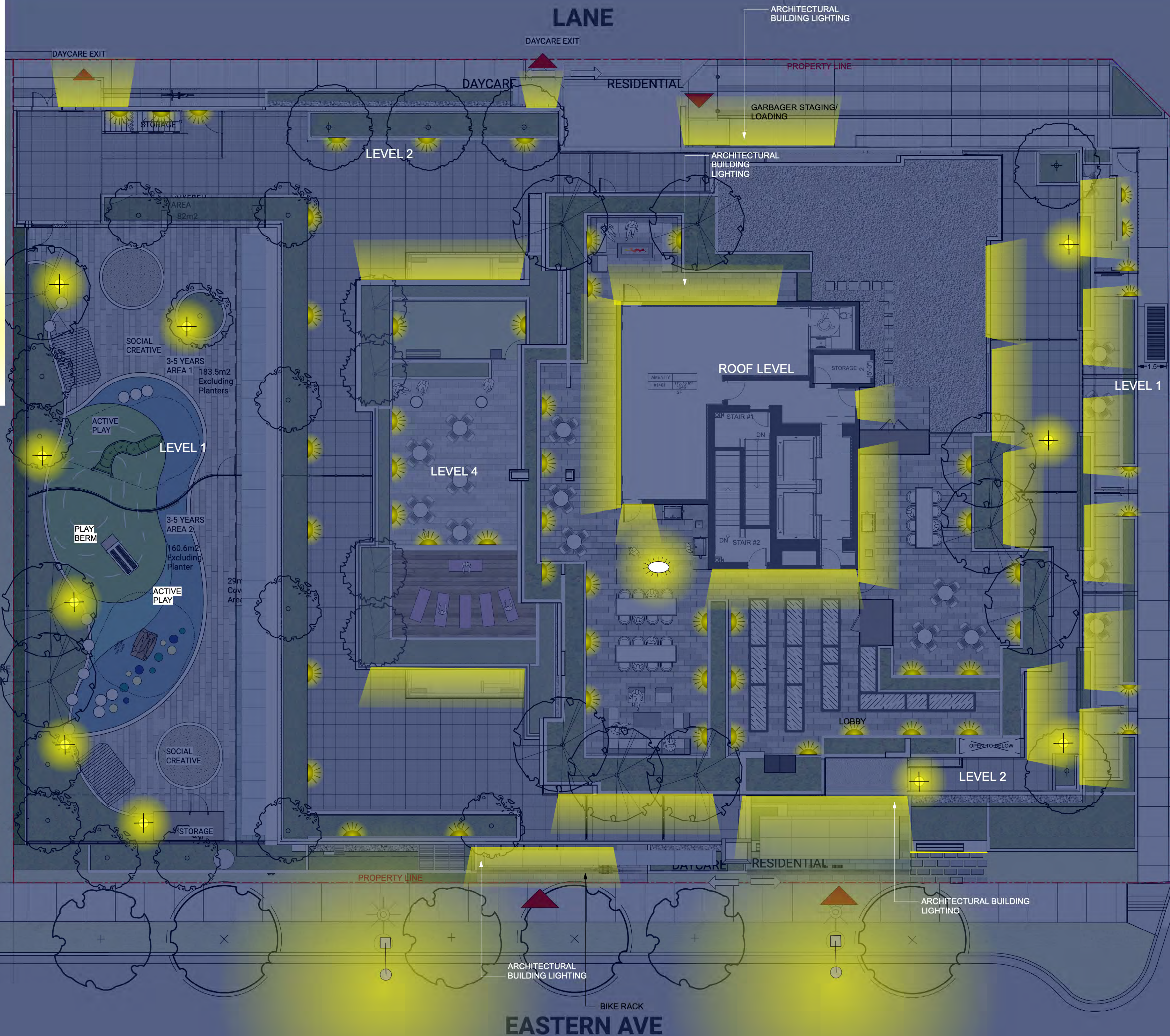

13	RE-ISSUED FOR REZONING	22-07-19
12	RE-ISSUED FOR REZONING	22-02-23
11	RE-ISSUED FOR REZONING	22-01-19
10	ISSUED FOR VCH REVIEW	21-12-22
9	ISSUED FOR VCH REVIEW	21-09-08
8	ISSUED FOR ADP	21-07-14
7	ISSUED FOR VCH REVIEW	21-05-26
6	ISSUED FOR VCH REVIEW	21-03-26
5	ISSUED FOR REZONING	20-10-14
4	ISSUED FOR VCH REVIEW	20-10-07
3	ISSUED FOR REVIEW	20-09-18
2	ISSUED FOR REVIEW	20-07-10
1	ISSUED FOR REVIEW	20-06-29

REVISIONS

1550-EASTERN AVENUE

1550- Eastern Ave
North Vancouver, BC

Scale:	1:100
Drawn:	MR
Reviewed:	KL
Project No.	06-705

OVERALL LANDSCAPE PLAN

Amended in Red
by
City of North Vancouver
May 2, 2023

Update Plant List to include coniferous trees to compensate the loss of existing coniferous trees on site.

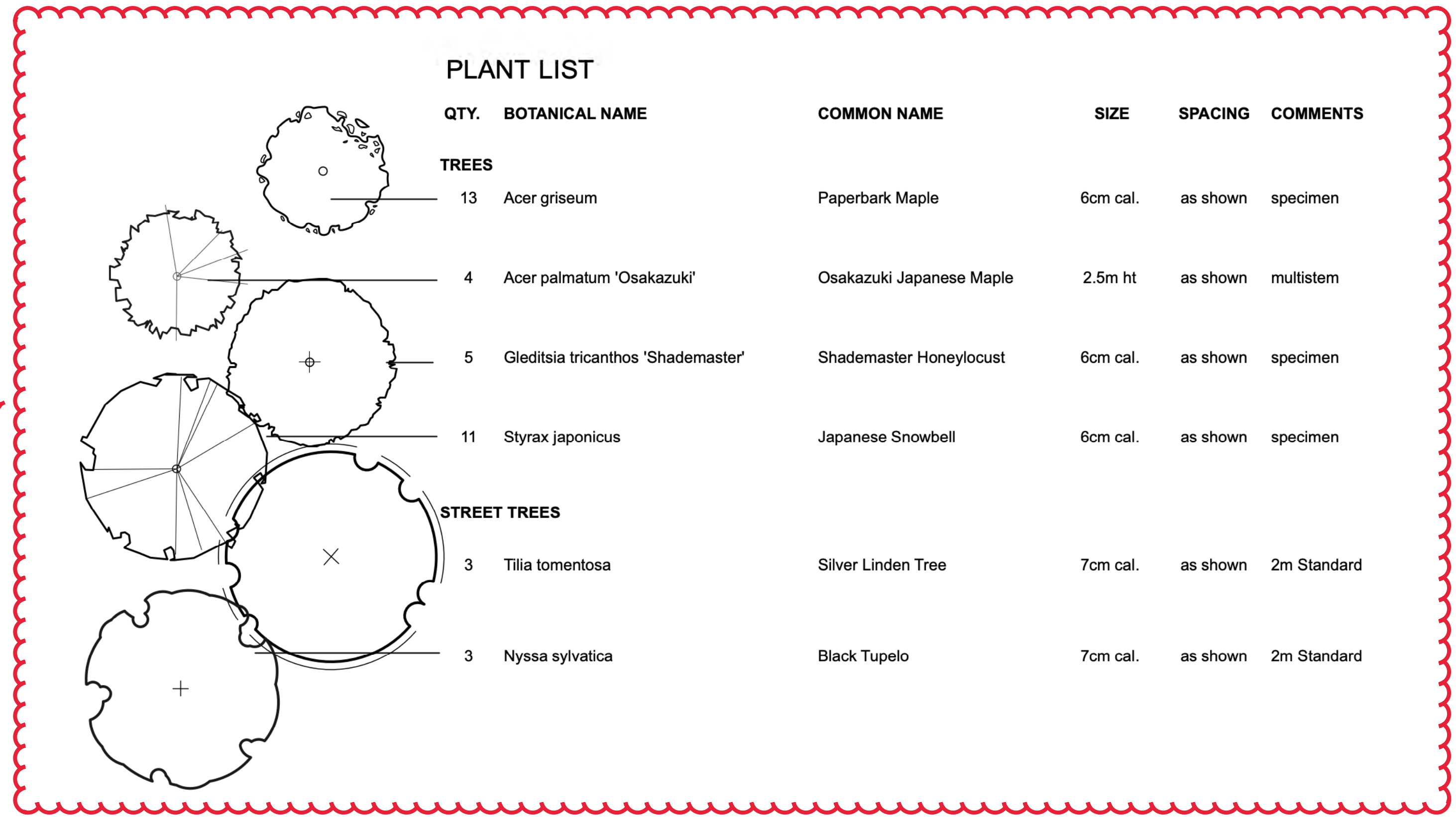

PLANT LIST

QTY.	BOTANICAL NAME	COMMON NAME	SIZE	SPACING	COMMENTS
------	----------------	-------------	------	---------	----------

TREES

13	Acer griseum	Paperbark Maple	6cm cal.	as shown	specimen
4	Acer palmatum 'Osakazuki'	Osakazuki Japanese Maple	2.5m ht	as shown	multistem
5	Gleditsia tricanthos 'Shademaster'	Shademaster Honeylocust	6cm cal.	as shown	specimen
11	Styrax japonicus	Japanese Snowbell	6cm cal.	as shown	specimen

STREET TREES

3	Tilia tomentosa	Silver Linden Tree	7cm cal.	as shown	2m Standard
3	Nyssa sylvatica	Black Tupelo	7cm cal.	as shown	2m Standard

SHRUBS

0	Buxus microphylla 'Green Beauty'	Green Beauty Boxwood	No. 5 Pot	450mm O.C.	full & bushy
36	Ceanothus 'Victoria' *	California Lilac	No. 3 Pot	900mm O.C.	fully established
35	Choysia x dewitteana 'Aztec Pearl'	Mexican Orange	No. 3 Pot	900mm O.C.	fully established
81	Ilex crenata 'Compacta'	Compact Japanese Holly	No. 3 Pot	600mm O.C.	fully established
19	Hydrangea paniculata 'Quick Fire'	Quick Fire panicle Hydrangea	No. 3 Pot	900mm O.C.	fully established
281	Nandina domestica 'Gulfstream'	Gulfstream Nandina	No. 2 Pot	600mm O.C.	fully established
175	Lavendula angustifolia 'Hidecote' *	Hidecote Lavender	No. 1 Pot	450mm O.C.	fully established
3	Rhododendron 'Ken Janek' *	Ken Janek Rhododendron	No. 2 Pot	750mm O.C.	fully established
13	Rhododendron 'Mardi Gras' *	Mardi Gras Rhododendron	No. 3 Pot	900mm O.C.	fully established
44	Polystichum munitum #	Sword Fern	No. 1 Pot	600mm O.C.	fully established
41	Sarcococca hookeriana humilis *	Dwarf Sweet box	No. 2 Pot	600mm O.C.	fully established
108	Taxus baccata repandens	Creeping Yew	No. 3 Pot	600mm O.C.	fully established
134	Taxus x media 'Hicksii'	Hicks Yew	No. 10 Pot	450mm O.C.	1.5m ht. min.
182	Vaccinium ovatum * #	Evergreen Huckleberry	No. 5 Pot	750mm O.C.	fully established

PERENNIALS AND GRASSES

29	Carex testacea 'Prairie Fire'	Prairie Fire Sedge	No. 1 Pot	450mm O.C.	fully established
257	Hakonechloa macra 'Aurea'	Golden Japanese Forest Grass	No. 1 Pot	380mm O.C.	fully established
111	Liriope muscari 'Big Blue' *	Big Blue Lilyturf	No. 1 Pot	300mm O.C.	fully established
29	Sedum 'Autumn Joy' *	Autumn Joy Sedum	No. 1 Pot	450mm O.C.	fully established

GROUNDCOVERS

32	Arctostaphylos uva-ursi * #	Kinnikinnick	4" (10cm) Pot	350mm O.C.	fully established
32	Fragaria chiloensis * #	Beach Strawberry	4" (10cm) Pot	350mm O.C.	fully established

NOTES:

* Indicates pollinator/bird friendly plants

Indicates native plants

PLANTING NOTES

- ALL PLANTING SHALL BE IN ACCORDANCE WITH CANADIAN LANDSCAPE STANDARDS LATEST EDITION.
- ALL TREE AND SHRUB BEDS ARE TO BE MULCHED WITH 50mm OF 2 MEDIUM FINE MULCH, LESS THAN 50mm DIAMETER.
- SEE SPECIFICATIONS AND DETAILS FOR PLANTING METHODS, REQUIREMENTS, SOIL TESTING, MATERIALS AND PLAN PROTECTION.
- ALL LANDSCAPE AREAS TO BE IRRIGATED WITH HIGH EFFICIENCY IRRIGATION SYSTEM.
- OFFSITE LANDSCAPE TO BE IRRIGATED TO CNV STANDARDS.
- ALL OFFSITE TREES TO HAVE MINIMUM OF 15m³ SOIL VOLUME.
- PRIOR TO THE START OF CONSTRUCTION, THE CONTRACTOR SHALL CONFIRM THE AVAILABILITY OF THE PLANT MATERIAL, ALLOWING FOR ANY AND ALL REQUIRED APPROVALS. PLANT SUBSTITUTIONS NOT CONFIRMED AND APPROVED BY THE LANDSCAPE ARCHITECT WILL BE REJECTED.
- WHERE PROVIDED, AREA TAKEOFFS AND PLANT QUANTITY ESTIMATES IN PLANT LIST ARE FOR INFORMATION ONLY. CONTRACTOR IS RESPONSIBLE TO DO THEIR OWN QUANTITY TAKEOFFS FOR ALL PLANT MATERIAL AND SIZES SHOWN ON THE DRAWINGS. BRING DISCREPANCIES TO THE ATTENTION OF THE LANDSCAPE ARCHITECT FOR CLARIFICATION.
- CONTRACTOR IS RESPONSIBLE TO 'RESTORE' ALL AREAS OF THE SITE, OR ADJACENT AREAS, WHERE DISTURBED THAT MEETS OR EXCEEDS THE CONDITIONS PRIOR TO DISTURBANCE.
- SEE SPECIFICATIONS AND DETAILS FOR PLANTING METHODS, REQUIREMENTS, SOIL TESTING, MATERIALS AND PLAN PROTECTION.

CONNECT LANDSCAPE ARCHITECTURE INC. DOES NOT GUARANTEE THE EXISTENCE, LOCATION, AND ELEVATION OF UTILITIES AND / OR CONCEALED STRUCTURES AT THE PROJECT SITE.

THE CONTRACTOR IS RESPONSIBLE FOR DETERMINING THE EXISTENCE, LOCATION, AND ELEVATION OF ALL UTILITIES AND / OR CONCEALED STRUCTURES, AND IS RESPONSIBLE FOR NOTIFYING THE APPROPRIATE COMPANY, DEPARTMENT OR PERSON(S) OF ITS INTENTION TO CARRY OUT ITS OPERATIONS.

13	RE-ISSUED FOR REZONING	22-07-19
12	RE-ISSUED FOR REZONING	22-02-23
11	RE-ISSUED FOR REZONING	22-01-19
10	ISSUED FOR VCH REVIEW	21-12-22
9	ISSUED FOR VCH REVIEW	21-09-08
8	ISSUED FOR ADP	21-07-14
7	ISSUED FOR VCH REVIEW	21-05-26
6	ISSUED FOR VCH REVIEW	21-03-26
5	ISSUED FOR REZONING	20-10-14
4	ISSUED FOR VCH REVIEW	20-10-07
3	ISSUED FOR REVIEW	20-09-18
2	ISSUED FOR REVIEW	20-07-10
1	ISSUED FOR REVIEW	20-06-29

REVISIONS

1550-EASTERN AVENUE

1550- Eastern Ave
North Vancouver, BC

Scale: 1:100

Drawn: MR

Reviewed: KL

Project No. 06-705

PLANT MATERIALS

CONNECT LANDSCAPE ARCHITECTURE INC. DOES NOT GUARANTEE THE EXISTENCE, LOCATION, AND ELEVATION OF UTILITIES AND / OR CONCEALED STRUCTURES AT THE PROJECT SITE.

THE CONTRACTOR IS RESPONSIBLE FOR DETERMINING THE EXISTENCE, LOCATION, AND ELEVATION OF ALL UTILITIES AND / OR CONCEALED STRUCTURES, AND IS RESPONSIBLE FOR NOTIFYING THE APPROPRIATE COMPANY, DEPARTMENT OR PERSON(S) OF ITS INTENTION TO CARRY OUT ITS OPERATIONS.

NOTE: REFER TO PLANT LIST ON L2.0

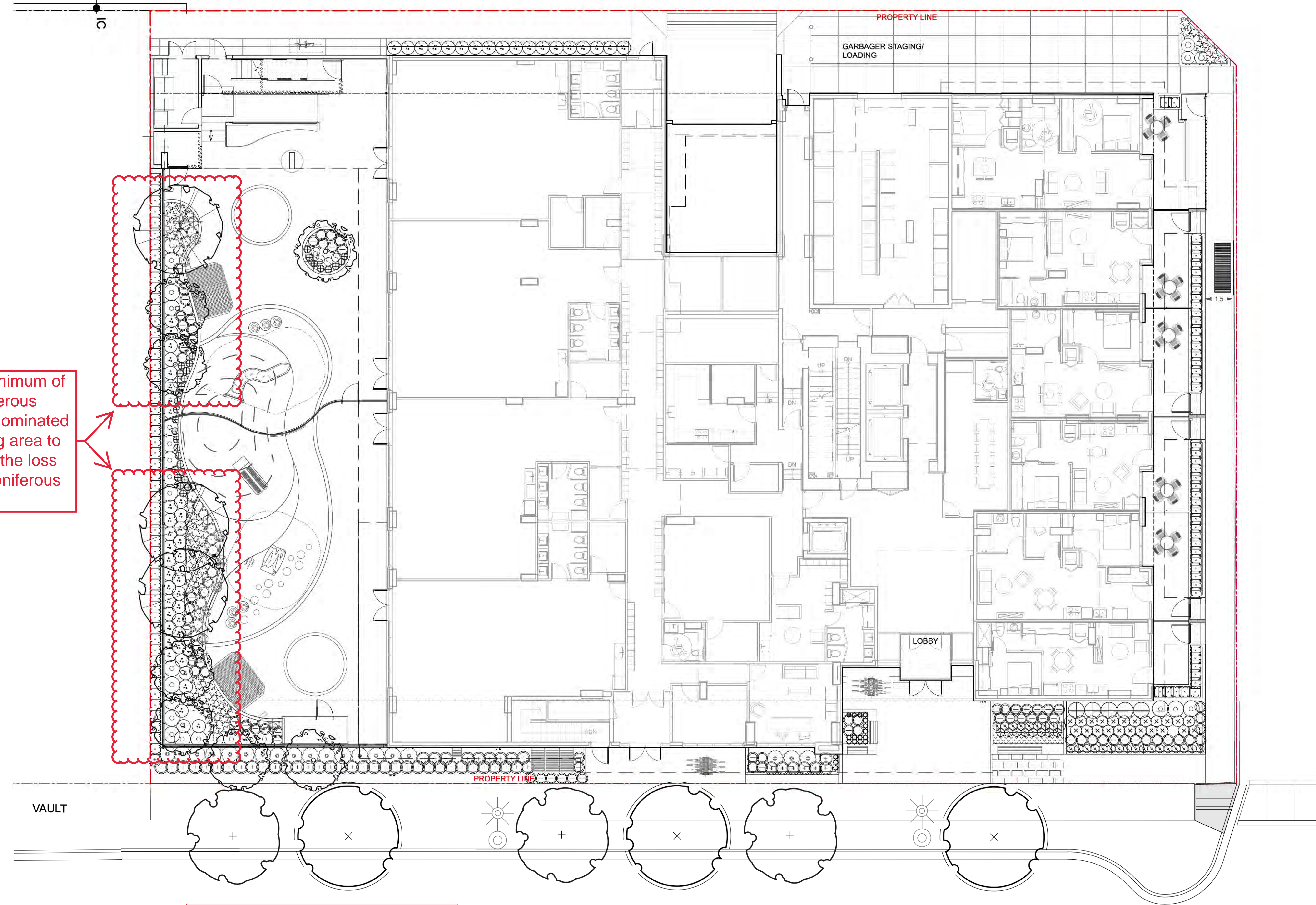

Provide a minimum of two (2) coniferous trees in the nominated deep planting area to compensate the loss of existing coniferous trees on site.

13	RE-ISSUED FOR REZONING	22-07-19
12	RE-ISSUED FOR REZONING	22-02-23
11	RE-ISSUED FOR REZONING	22-01-19
10	ISSUED FOR VCH REVIEW	21-12-22
9	ISSUED FOR VCH REVIEW	21-09-08
8	ISSUED FOR ADP	21-07-14
7	ISSUED FOR VCH REVIEW	21-05-26
6	ISSUED FOR VCH REVIEW	21-03-26
5	ISSUED FOR REZONING	20-10-14
4	ISSUED FOR VCH REVIEW	20-10-07
3	ISSUED FOR REVIEW	20-09-18
2	ISSUED FOR REVIEW	20-07-10
1	ISSUED FOR REVIEW	20-06-29

REVISIONS

1550-EASTERN AVENUE

1550- Eastern Ave
North Vancouver, BC

Scale:	1:100
Drawn:	MR
Reviewed:	KL
Project No.	06-705

**PLANTING PLAN
LEVEL 1**

Amended in Red
by
City of North Vancouver
May 2, 2023

1 PLANTING PLAN
Scale: 1:100

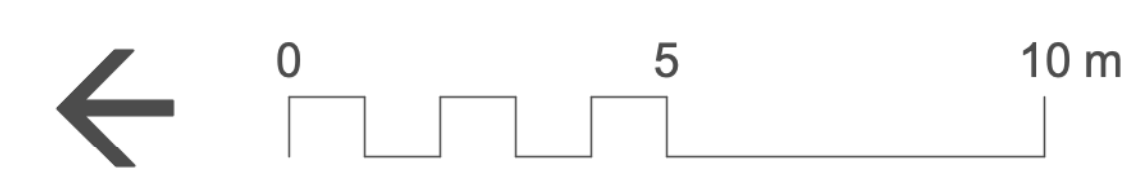

L2.1

NOTE: REFER TO PLANT LIST ON L2.0

CONNECT LANDSCAPE ARCHITECTURE INC.
DOES NOT GUARANTEE THE EXISTENCE,
LOCATION, AND ELEVATION OF UTILITIES AND /
OR CONCEALED STRUCTURES AT THE PROJECT
SITE.

THE CONTRACTOR IS RESPONSIBLE FOR
DETERMINING THE EXISTENCE, LOCATION, AND
ELEVATION OF ALL UTILITIES AND / OR
CONCEALED STRUCTURES, AND IS
RESPONSIBLE FOR NOTIFYING THE
APPROPRIATE COMPANY, DEPARTMENT OR
PERSON(S) OF ITS INTENTION TO CARRY OUT ITS
OPERATIONS.

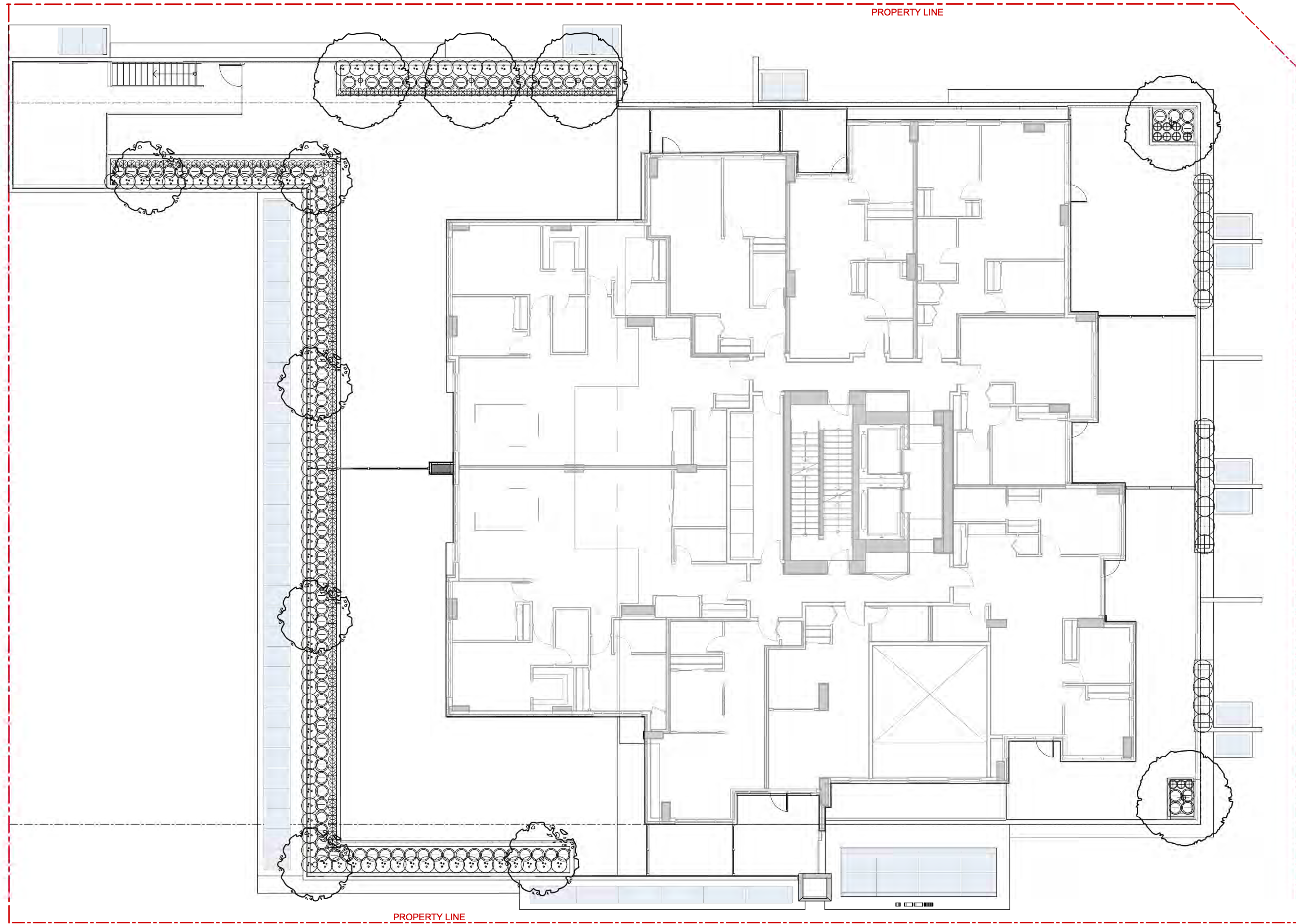

13	RE-ISSUED FOR REZONING	22-07-19
12	RE-ISSUED FOR REZONING	22-02-23
11	RE-ISSUED FOR REZONING	22-01-19
10	ISSUED FOR VCH REVIEW	21-12-22
9	ISSUED FOR VCH REVIEW	21-09-08
8	ISSUED FOR ADP	21-07-14
7	ISSUED FOR VCH REVIEW	21-05-26
6	ISSUED FOR VCH REVIEW	21-03-26
5	ISSUED FOR REZONING	20-10-14
4	ISSUED FOR VCH REVIEW	20-10-07
3	ISSUED FOR REVIEW	20-09-18
2	ISSUED FOR REVIEW	20-07-10
1	ISSUED FOR REVIEW	20-06-29

REVISIONS

1550-EASTERN AVENUE

1550- Eastern Ave
North Vancouver, BC

Scale:	1:100
Drawn:	MR
Reviewed:	KL
Project No.	06-705

LEVEL 2
PLANTING PLAN

1 LEVEL 2 PLANTING PLAN
Scale: 1:100

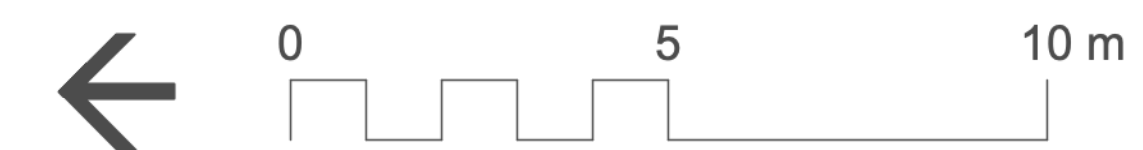

CONNECT LANDSCAPE ARCHITECTURE INC.
DOES NOT GUARANTEE THE EXISTENCE,
LOCATION, AND ELEVATION OF UTILITIES AND /
OR CONCEALED STRUCTURES AT THE PROJECT
SITE.

THE CONTRACTOR IS RESPONSIBLE FOR
DETERMINING THE EXISTENCE, LOCATION, AND
ELEVATION OF ALL UTILITIES AND / OR
CONCEALED STRUCTURES, AND IS
RESPONSIBLE FOR NOTIFYING THE
APPROPRIATE COMPANY, DEPARTMENT OR
PERSON(S) OF ITS INTENTION TO CARRY OUT ITS
OPERATIONS.

NOTE: REFER TO PLANT LIST ON L2.0

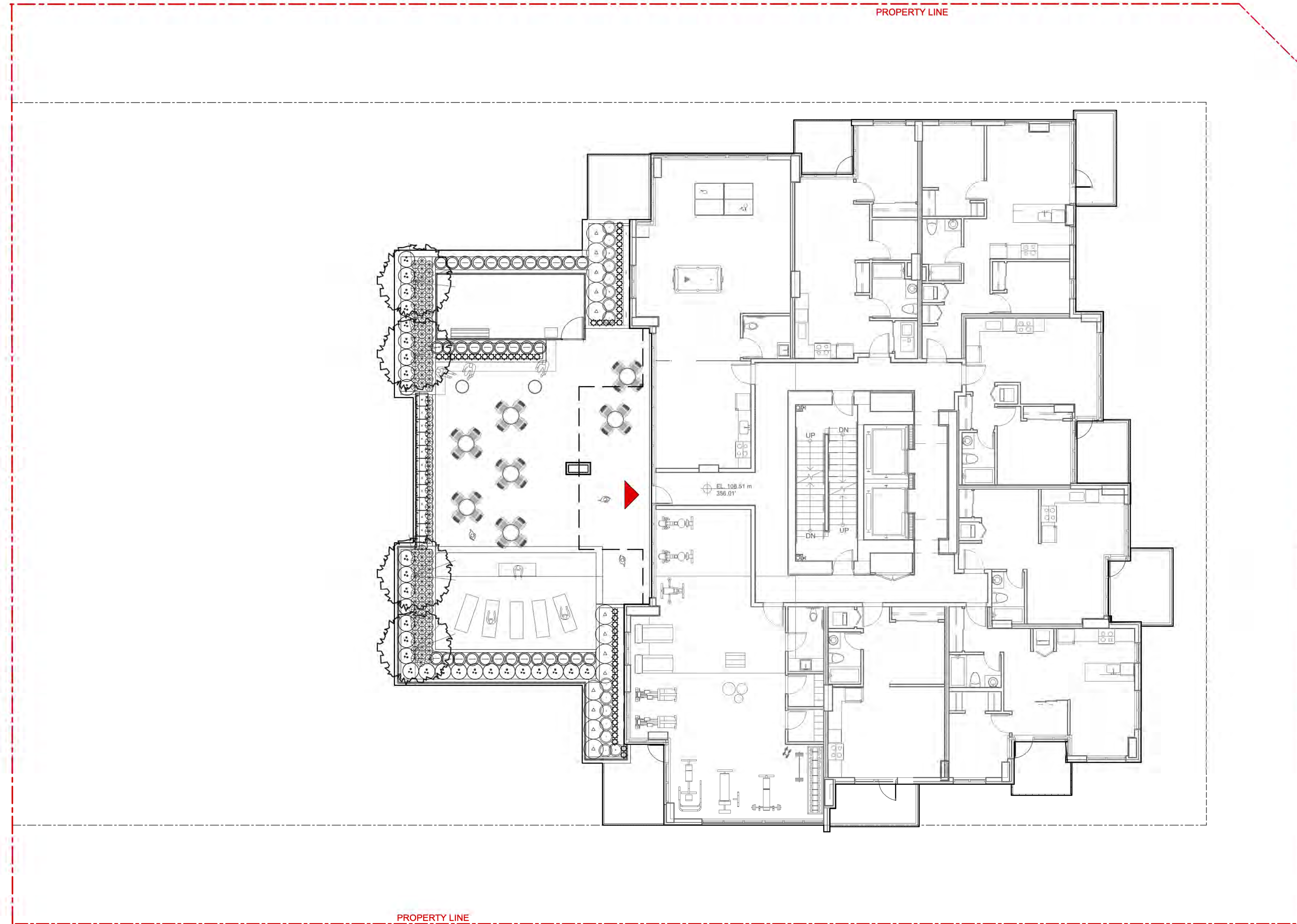

13	RE-ISSUED FOR REZONING	22-07-19
12	RE-ISSUED FOR REZONING	22-02-23
11	RE-ISSUED FOR REZONING	22-01-19
10	ISSUED FOR VCH REVIEW	21-12-22
9	ISSUED FOR VCH REVIEW	21-09-08
8	ISSUED FOR ADP	21-07-14
7	ISSUED FOR VCH REVIEW	21-05-26
6	ISSUED FOR VCH REVIEW	21-03-26
5	ISSUED FOR REZONING	20-10-14
4	ISSUED FOR VCH REVIEW	20-10-07
3	ISSUED FOR REVIEW	20-09-18
2	ISSUED FOR REVIEW	20-07-10
1	ISSUED FOR REVIEW	20-06-29

REVISIONS

1550-EASTERN AVENUE

1550- Eastern Ave
North Vancouver, BC

Scale:	1:100
Drawn:	MR
Reviewed:	KL
Project No.	06-705

LEVEL 4 PLANTING PLAN

1 LEVEL 4 PLANTING PLAN
Scale: 1:100

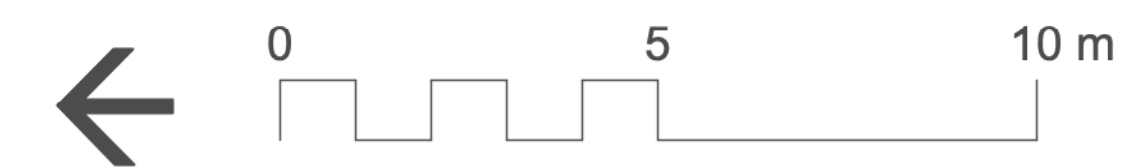

NOTE: REFER TO PLANT LIST ON L2.0

CONNECT LANDSCAPE ARCHITECTURE INC.
DOES NOT GUARANTEE THE EXISTENCE,
LOCATION, AND ELEVATION OF UTILITIES AND /
OR CONCEALED STRUCTURES AT THE PROJECT
SITE.

THE CONTRACTOR IS RESPONSIBLE FOR
DETERMINING THE EXISTENCE, LOCATION, AND
ELEVATION OF ALL UTILITIES AND / OR
CONCEALED STRUCTURES, AND IS
RESPONSIBLE FOR NOTIFYING THE
APPROPRIATE COMPANY, DEPARTMENT OR
PERSON(S) OF ITS INTENTION TO CARRY OUT ITS
OPERATIONS.

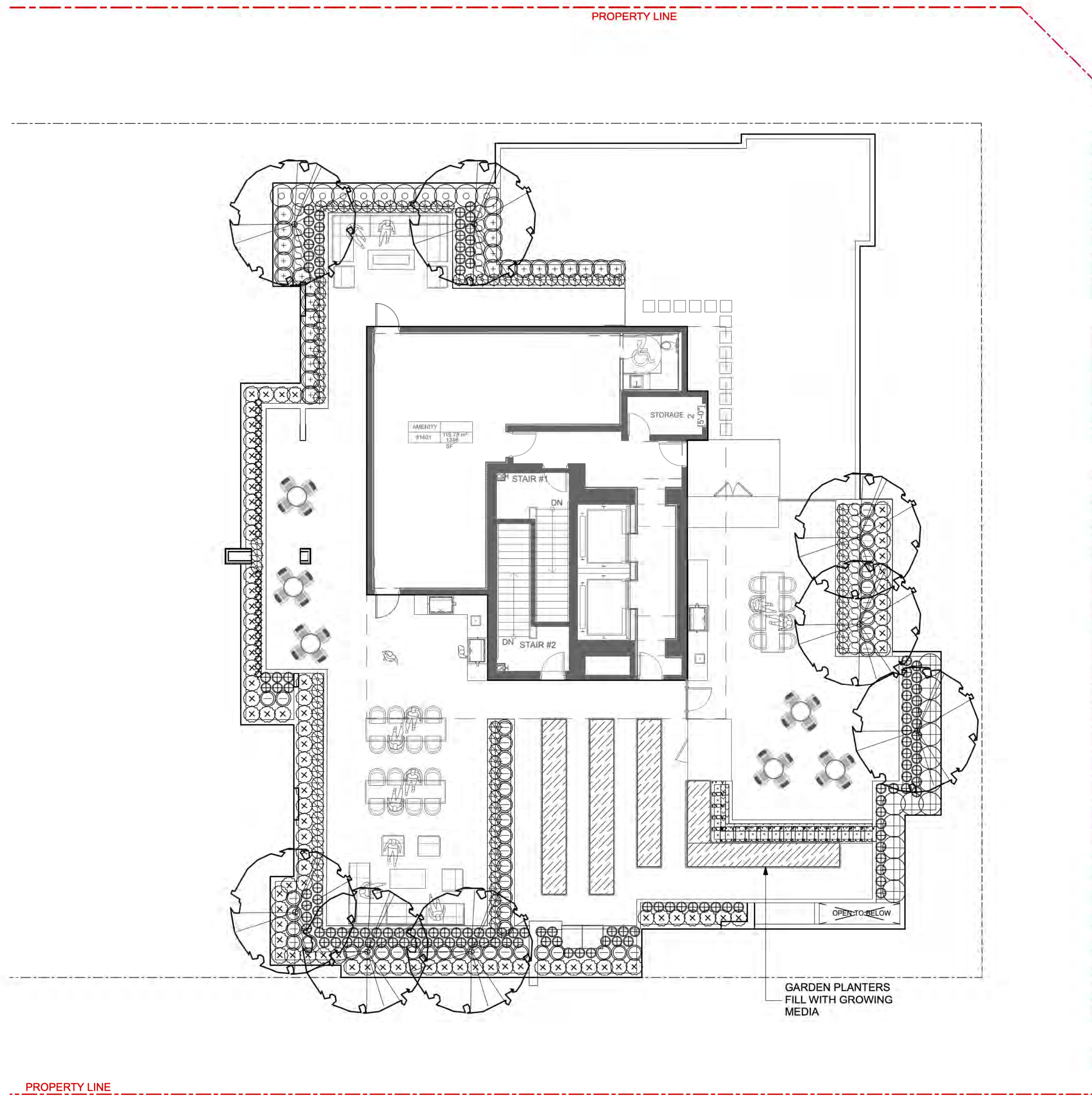

13	RE-ISSUED FOR REZONING	22-07-19
12	RE-ISSUED FOR REZONING	22-02-23
11	RE-ISSUED FOR REZONING	22-01-19
10	ISSUED FOR VCH REVIEW	21-12-22
9	ISSUED FOR VCH REVIEW	21-09-08
8	ISSUED FOR ADP	21-07-14
7	ISSUED FOR VCH REVIEW	21-05-26
6	ISSUED FOR VCH REVIEW	21-03-26
5	ISSUED FOR REZONING	20-10-14
4	ISSUED FOR VCH REVIEW	20-10-07
3	ISSUED FOR REVIEW	20-09-18
2	ISSUED FOR REVIEW	20-07-10
1	ISSUED FOR REVIEW	20-06-29

REVISIONS

1550-EASTERN AVENUE

1550- Eastern Ave
North Vancouver, BC

Scale:	1:100
Drawn:	MR
Reviewed:	KL
Project No.	06-705

ROOF LEVEL PLANTING PLAN

1 ROOF PLANTING PLAN
Scale: 1:100

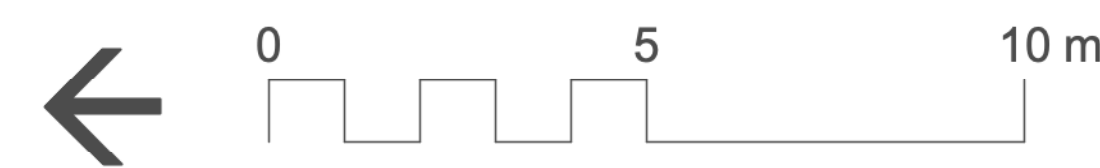

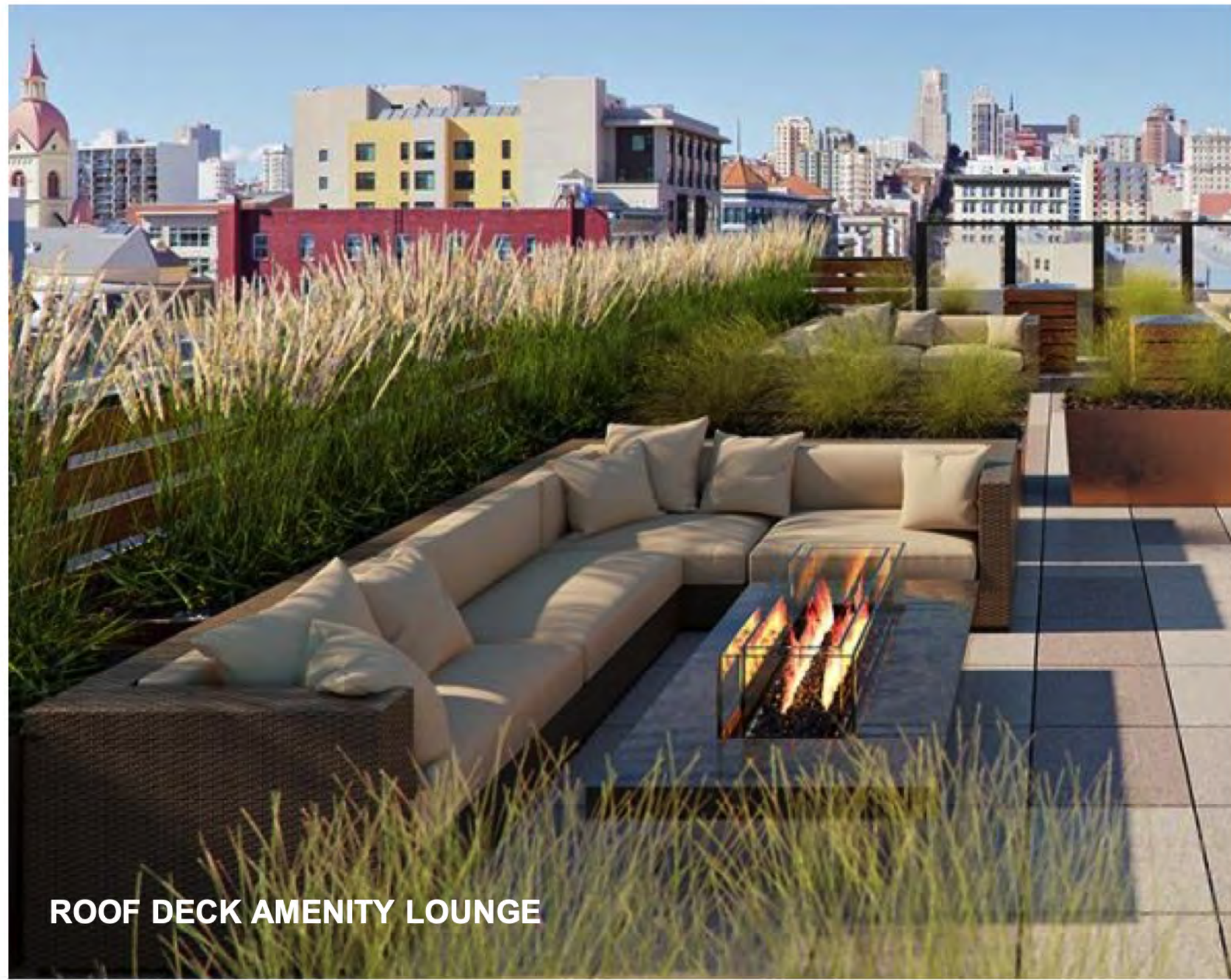

ROOF DECK AMENITY LOUNGE

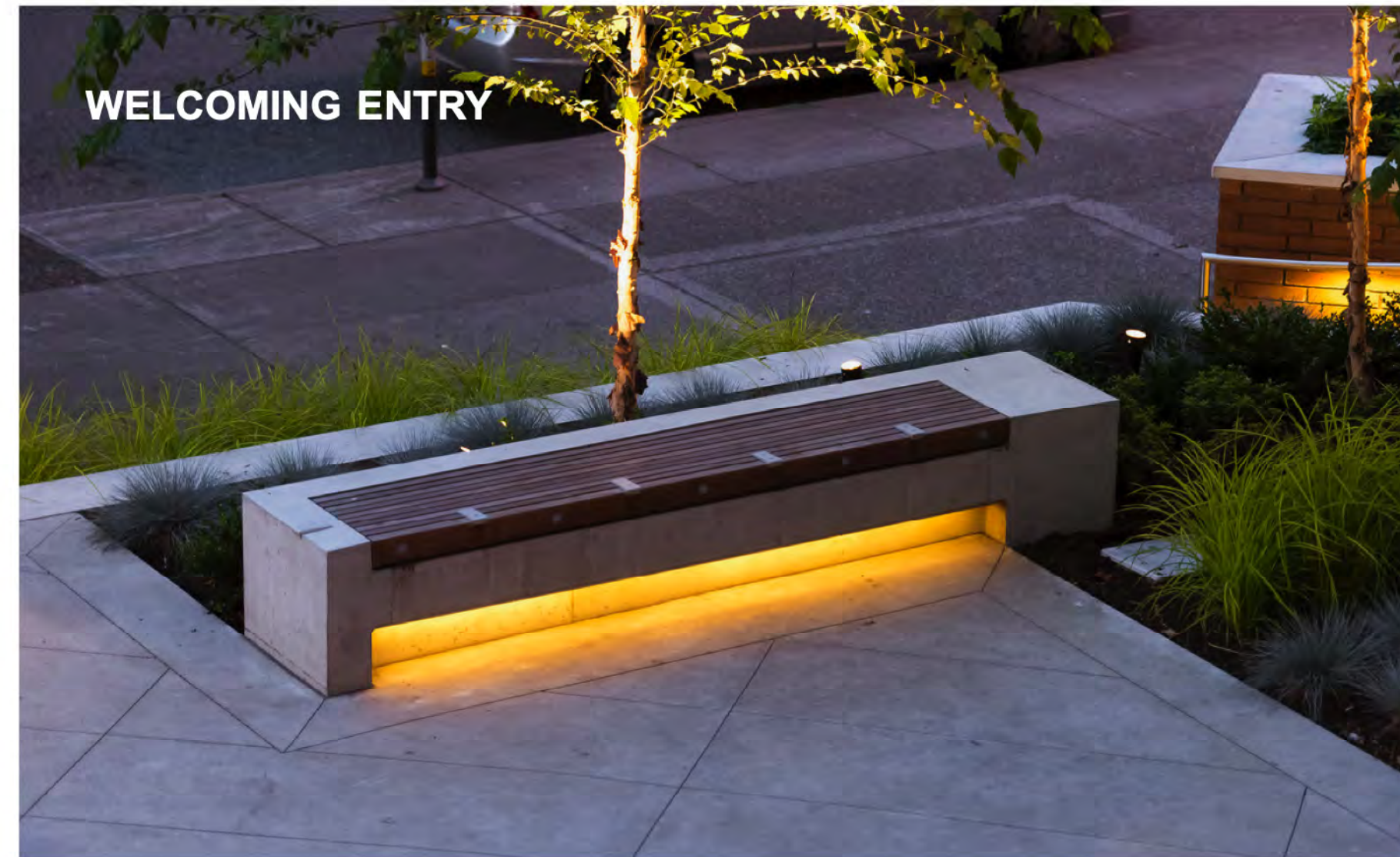

WELCOMING ENTRY



KIDS PLAY



LAYERED STREET FRONTAGE PLANTING



URBAN AGRICULTURE



OUTDOOR DINING AND BBQ AREA



SUNNING/ YOGA DECK



DOG RETREAT



DAYCARE

CONNECT LANDSCAPE ARCHITECTURE INC. DOES NOT GUARANTEE THE EXISTENCE, LOCATION, AND ELEVATION OF UTILITIES AND / OR CONCEALED STRUCTURES AT THE PROJECT SITE.

THE CONTRACTOR IS RESPONSIBLE FOR DETERMINING THE EXISTENCE, LOCATION, AND ELEVATION OF ALL UTILITIES AND / OR CONCEALED STRUCTURES, AND IS RESPONSIBLE FOR NOTIFYING THE APPROPRIATE COMPANY, DEPARTMENT OR PERSON(S) OF ITS INTENTION TO CARRY OUT ITS OPERATIONS.

13	RE-ISSUED FOR REZONING	22-07-19
12	RE-ISSUED FOR REZONING	22-02-23
11	RE-ISSUED FOR REZONING	22-01-19
10	ISSUED FOR VCH REVIEW	21-12-22
9	ISSUED FOR VCH REVIEW	21-09-08
8	ISSUED FOR ADP	21-07-14
7	ISSUED FOR VCH REVIEW	21-05-26
6	ISSUED FOR VCH REVIEW	21-03-26
5	ISSUED FOR REZONING	20-10-14
4	ISSUED FOR VCH REVIEW	20-10-07
3	ISSUED FOR REVIEW	20-09-18
2	ISSUED FOR REVIEW	20-07-10
1	ISSUED FOR REVIEW	20-06-29

REVISIONS

1550-EASTERN AVENUE

1550- Eastern Ave
North Vancouver, BC

Scale:	AS SHOWN
Drawn:	MR
Reviewed:	KL
Project No.	06-705

PRECEDENTS

CONNECT LANDSCAPE ARCHITECTURE INC. DOES NOT GUARANTEE THE EXISTENCE, LOCATION, AND ELEVATION OF UTILITIES AND / OR CONCEALED STRUCTURES AT THE PROJECT SITE.

THE CONTRACTOR IS RESPONSIBLE FOR DETERMINING THE EXISTENCE, LOCATION, AND ELEVATION OF ALL UTILITIES AND / OR CONCEALED STRUCTURES, AND IS RESPONSIBLE FOR NOTIFYING THE APPROPRIATE COMPANY, DEPARTMENT OR PERSON(S) OF ITS INTENTION TO CARRY OUT ITS OPERATIONS.

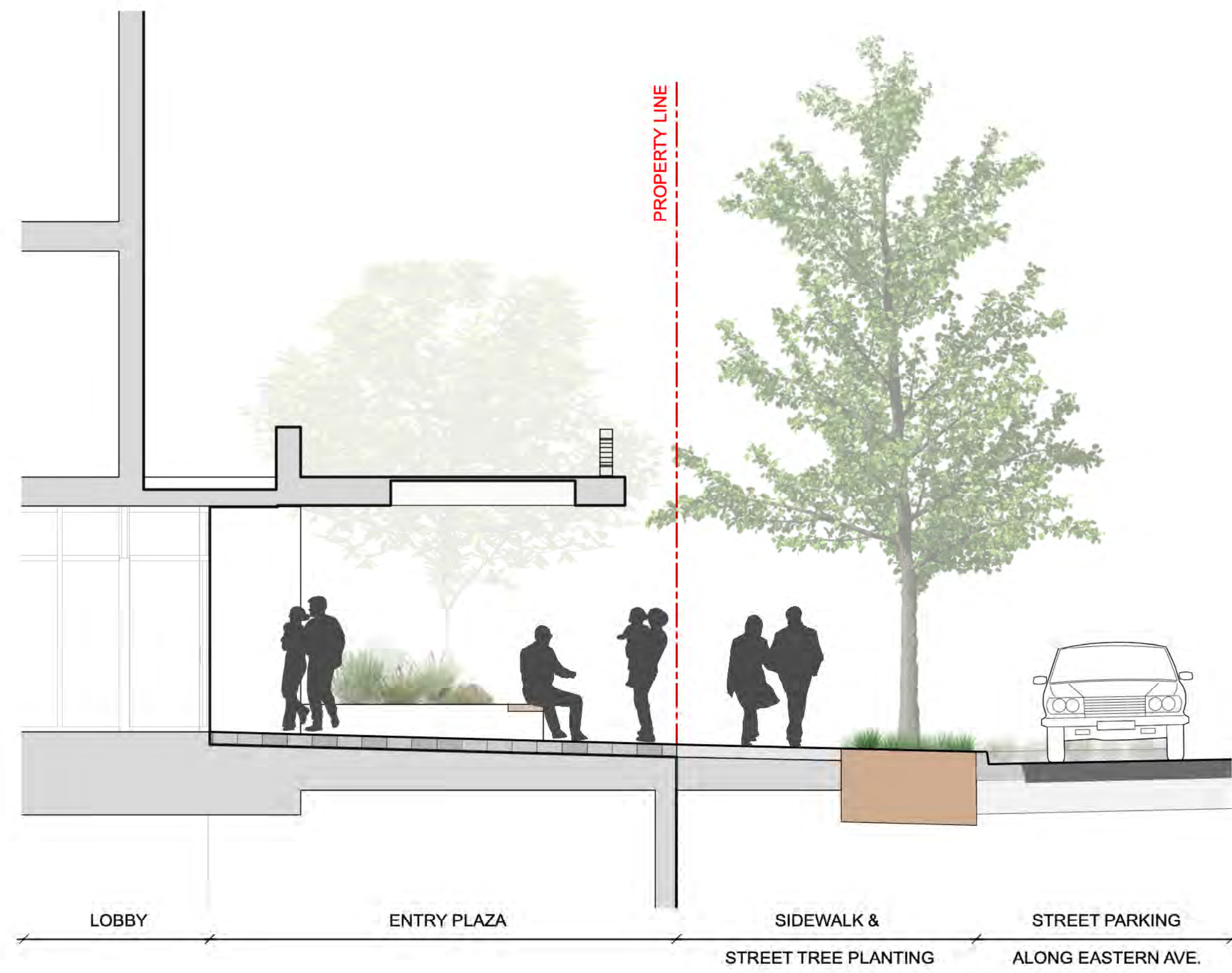

A SECTION - LEVEL 1 MAIN ENTRY
Scale: 1:50

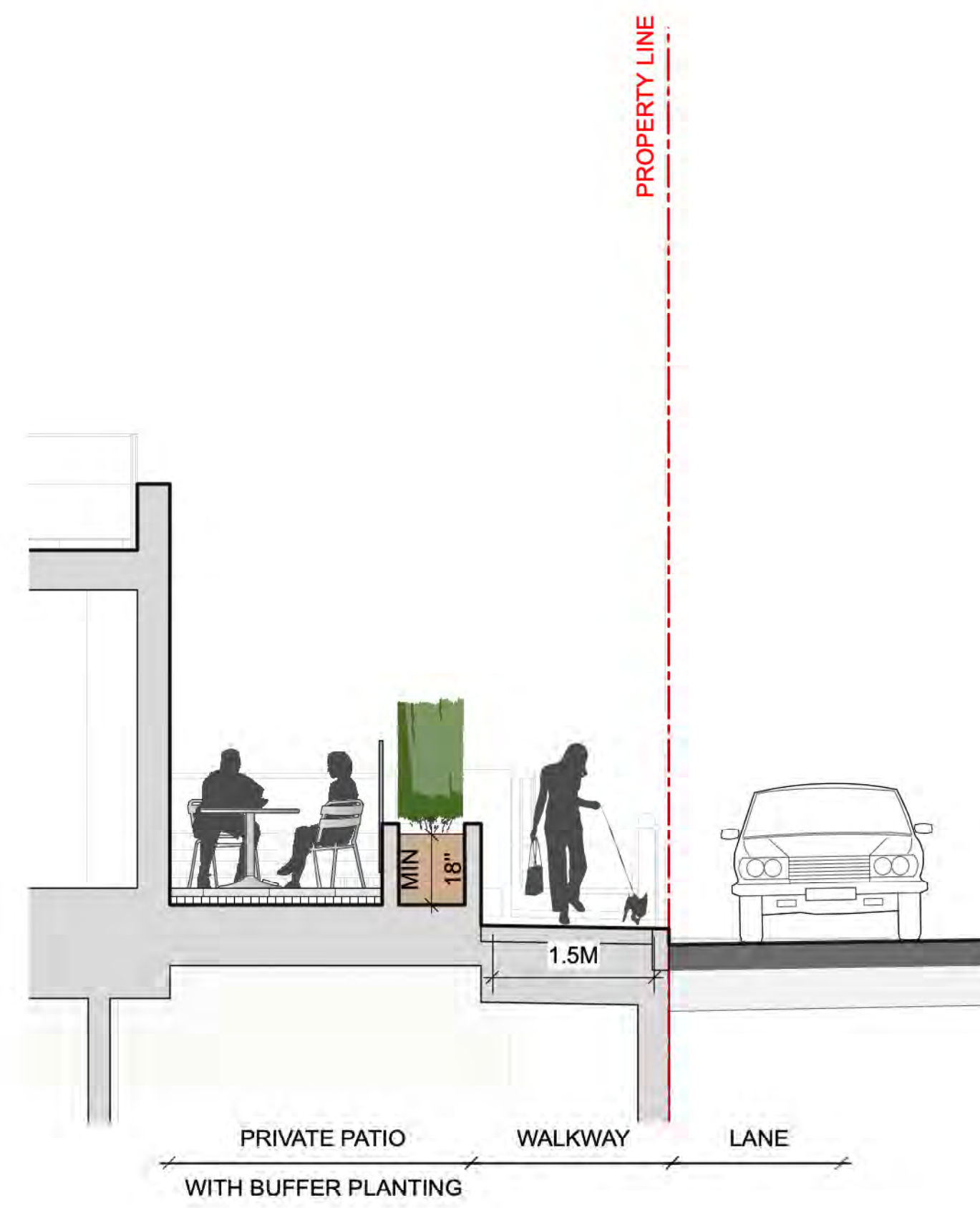

C SECTION - LEVEL 1 AT LANE
Scale: 1:50

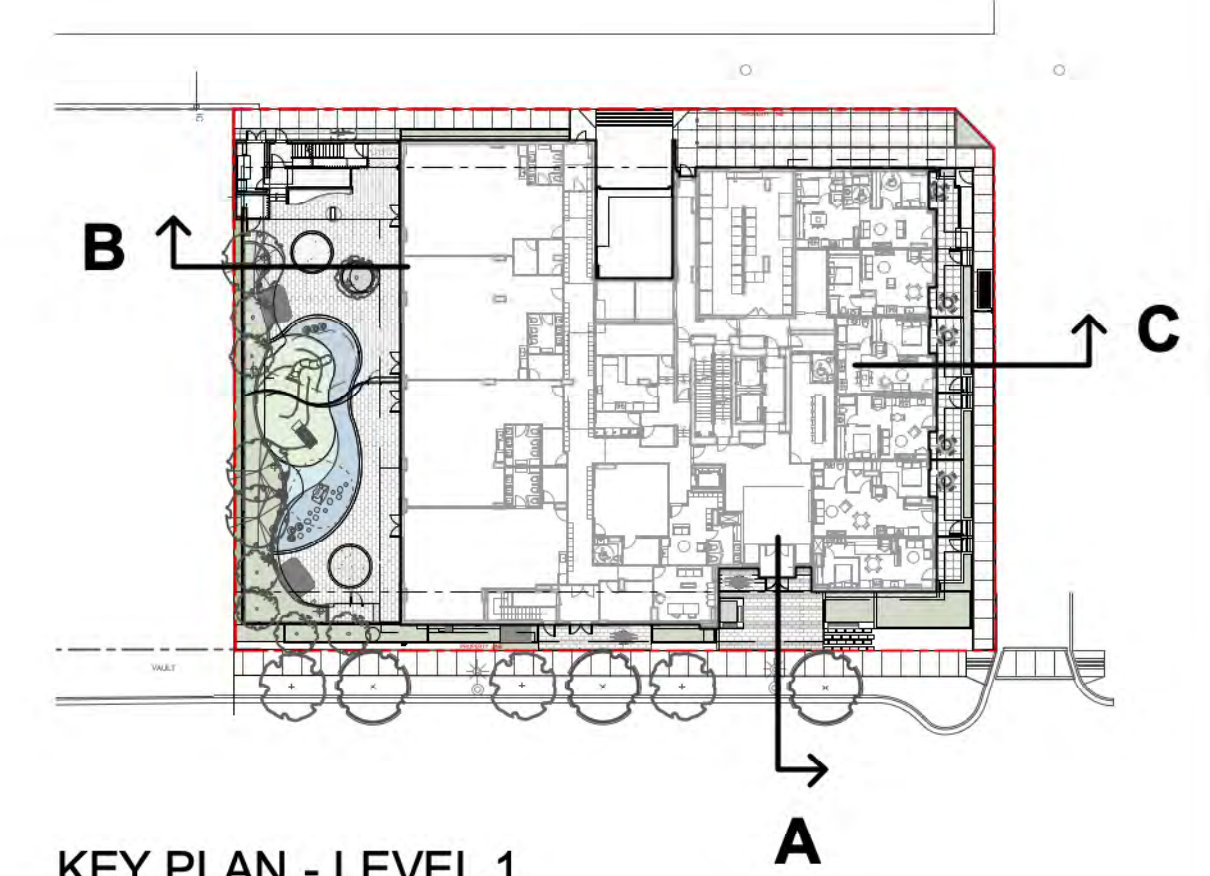

KEY PLAN - LEVEL 1

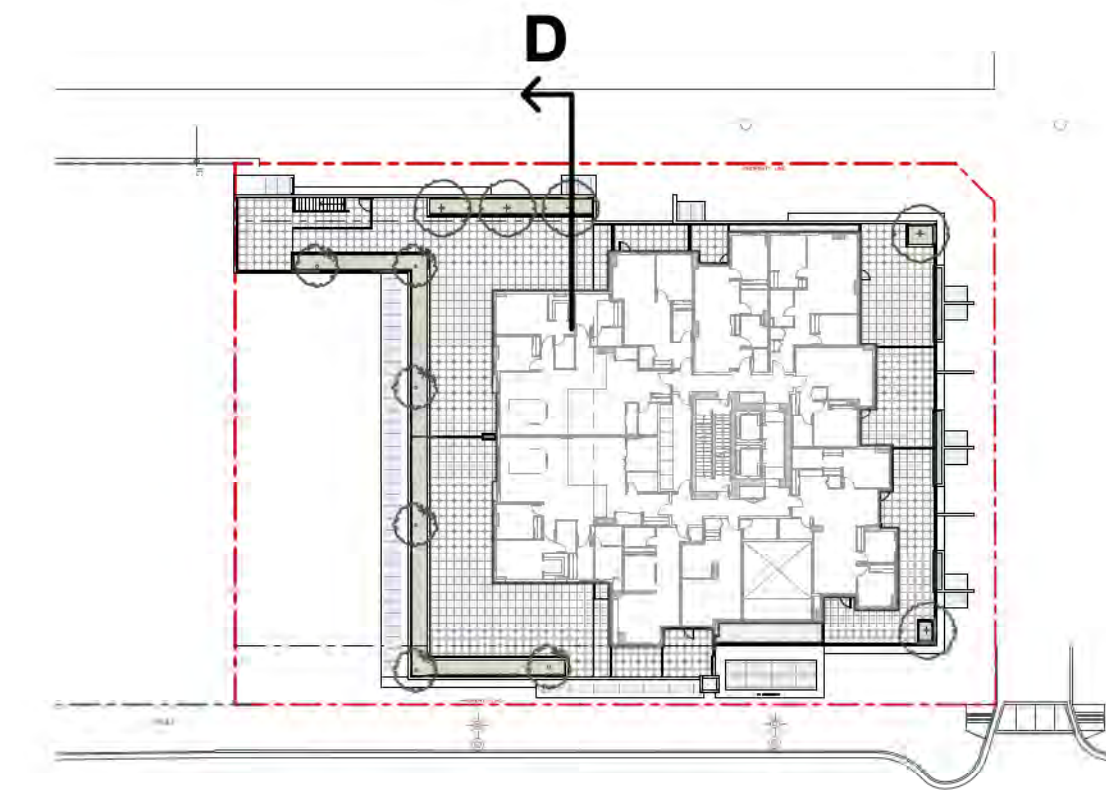

KEY PLAN - LEVEL 2

13	RE-ISSUED FOR REZONING	22-07-19
12	RE-ISSUED FOR REZONING	22-02-23
11	RE-ISSUED FOR REZONING	22-01-19
10	ISSUED FOR VCH REVIEW	21-12-22
9	ISSUED FOR VCH REVIEW	21-09-08
8	ISSUED FOR ADP	21-07-14
7	ISSUED FOR VCH REVIEW	21-05-26
6	ISSUED FOR VCH REVIEW	21-03-26
5	ISSUED FOR REZONING	20-10-14
4	ISSUED FOR VCH REVIEW	20-10-07
3	ISSUED FOR REVIEW	20-09-18
2	ISSUED FOR REVIEW	20-07-10
1	ISSUED FOR REVIEW	20-06-29

REVISIONS

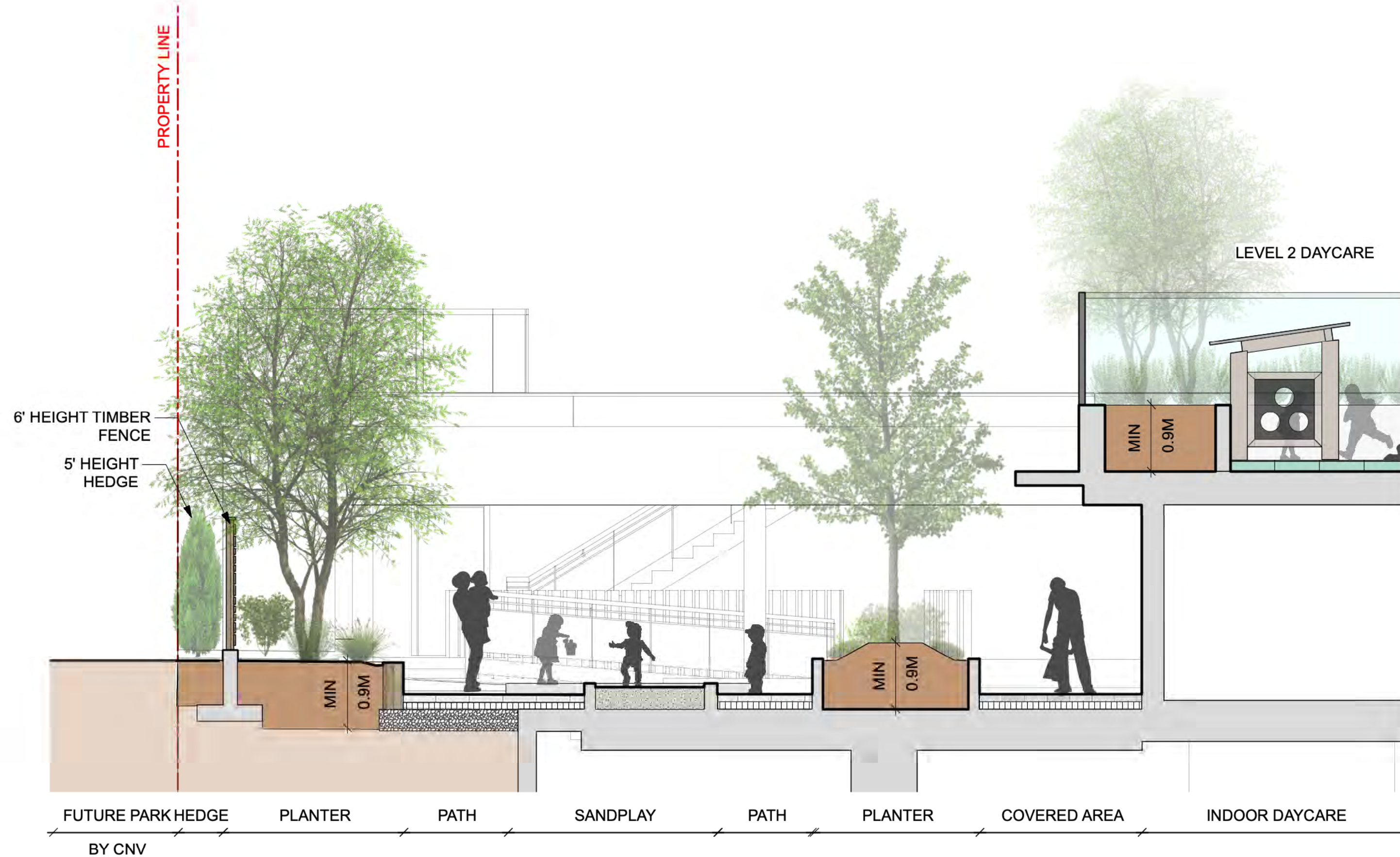

B SECTION - LEVEL 1 DAYCARE
Scale: 1:50

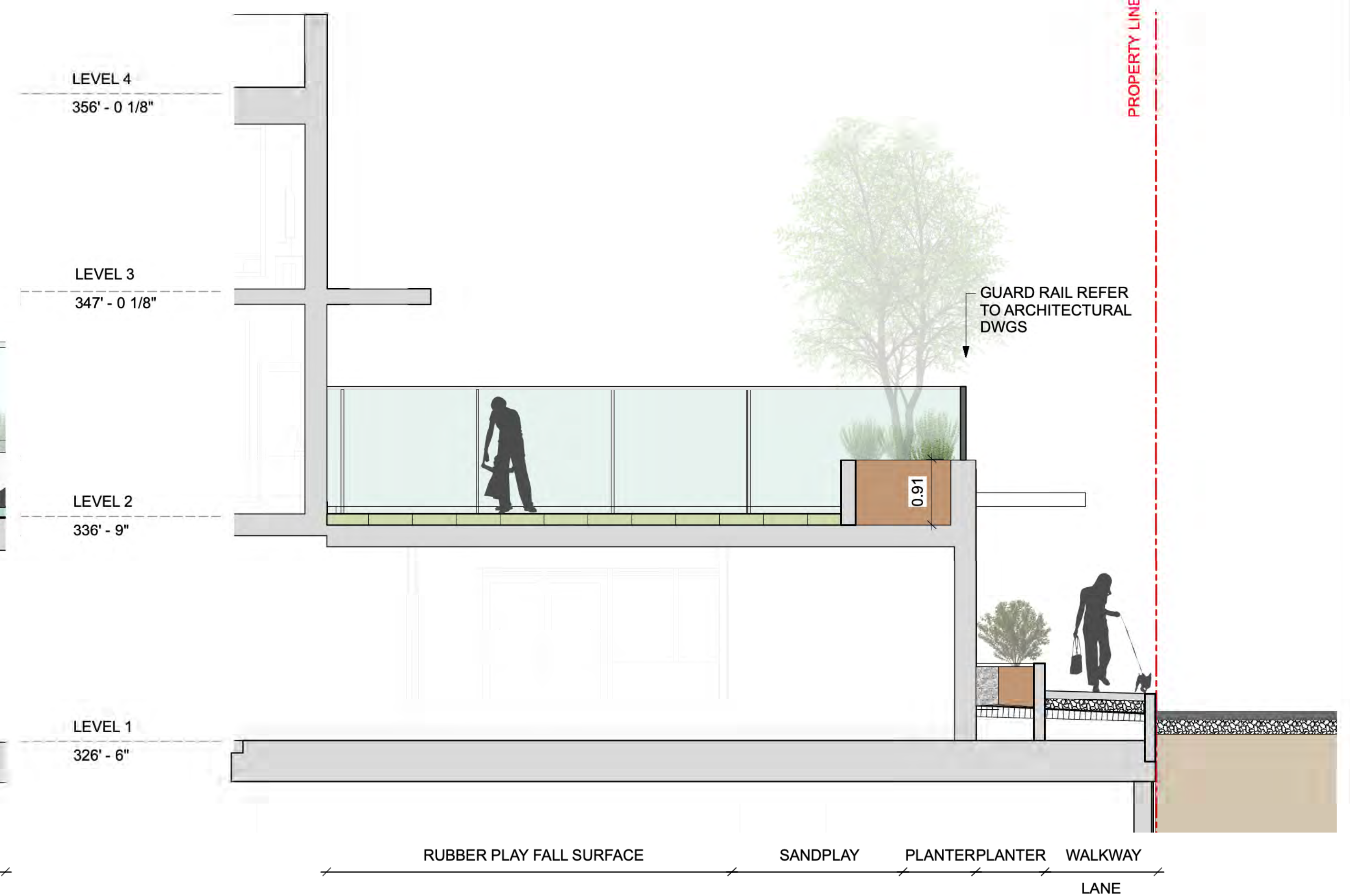

D SECTION - LEVEL 2 DAYCARE DECK
Scale: 1:50



1550-EASTERN AVENUE

1550- Eastern Ave
North Vancouver, BC

Scale:	AS SHOWN
Drawn:	MR
Reviewed:	KL
Project No.	06-705

LANDSCAPE SECTIONS

CONNECT LANDSCAPE ARCHITECTURE INC. DOES NOT GUARANTEE THE EXISTENCE, LOCATION, AND ELEVATION OF UTILITIES AND / OR CONCEALED STRUCTURES AT THE PROJECT SITE.

THE CONTRACTOR IS RESPONSIBLE FOR DETERMINING THE EXISTENCE, LOCATION, AND ELEVATION OF ALL UTILITIES AND / OR CONCEALED STRUCTURES, AND IS RESPONSIBLE FOR NOTIFYING THE APPROPRIATE COMPANY, DEPARTMENT OR PERSON(S) OF ITS INTENTION TO CARRY OUT ITS OPERATIONS.

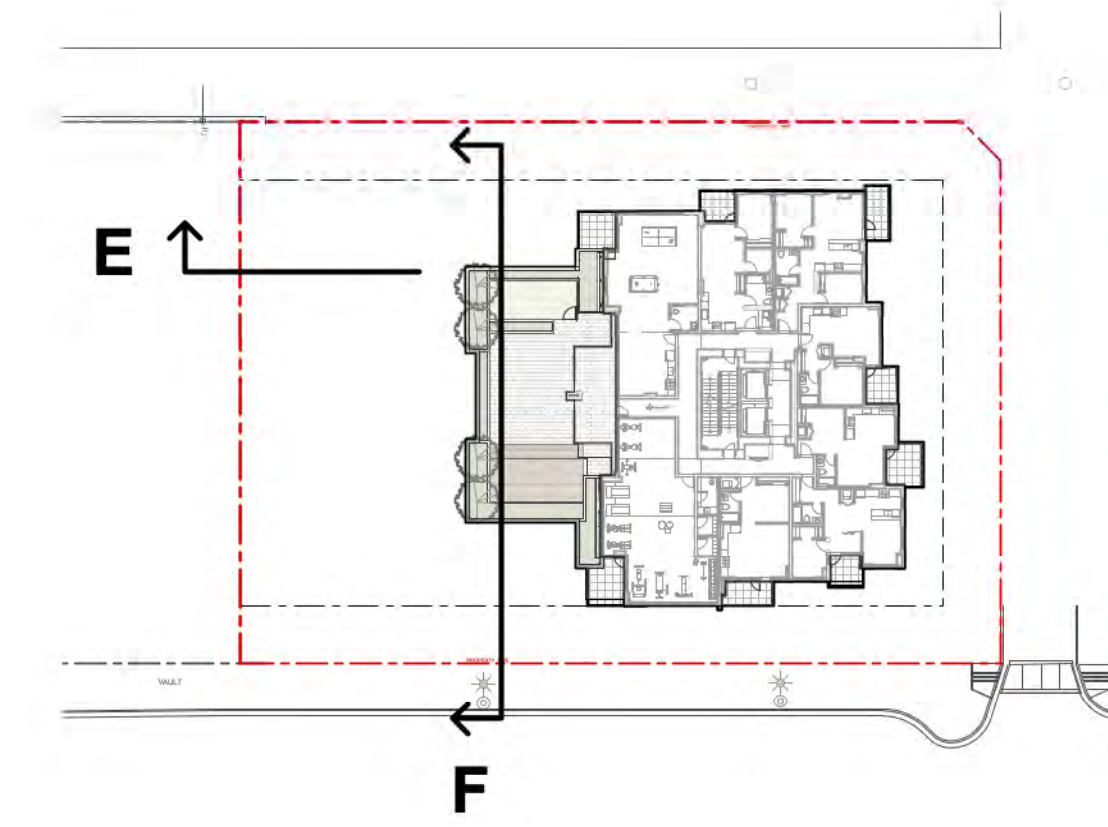

KEY PLAN - LEVEL 4



E SECTION - LEVEL 4 AMENITY
Scale: 1:50

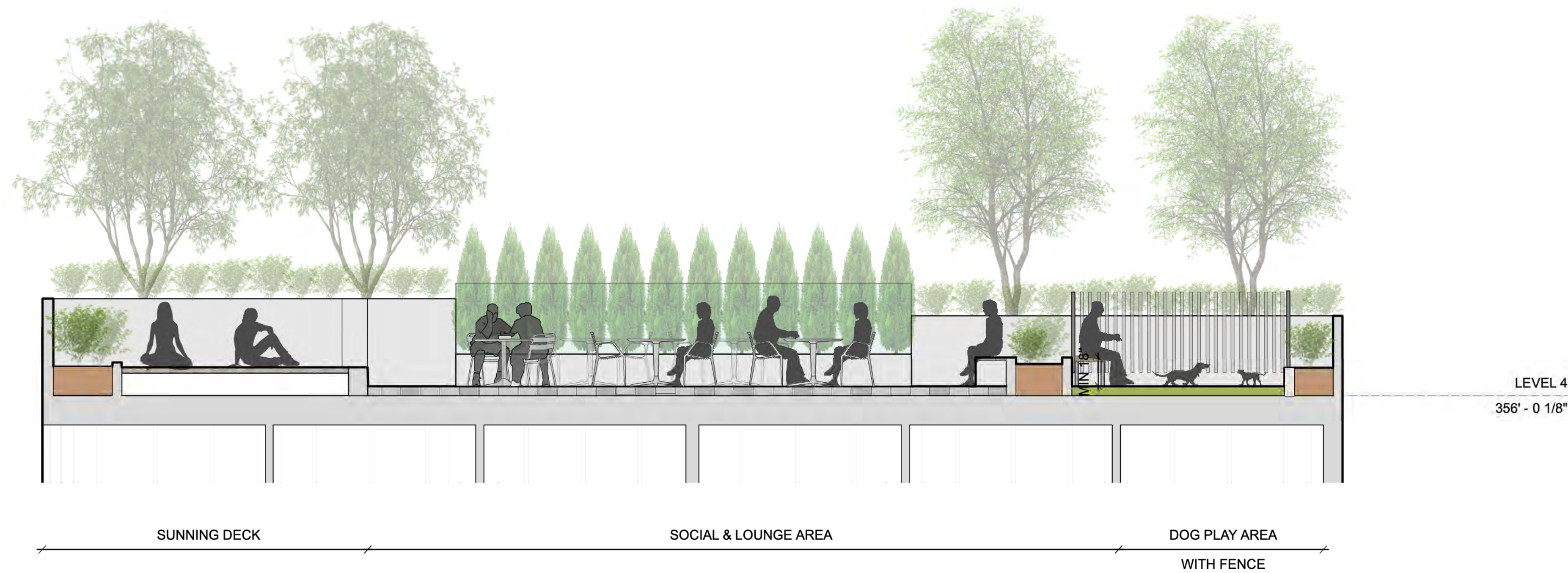

F SECTION - LEVEL 4 AMENITY
Scale: 1:50



13	RE-ISSUED FOR REZONING	22-07-19
12	RE-ISSUED FOR REZONING	22-02-23
11	RE-ISSUED FOR REZONING	22-01-19
10	ISSUED FOR VCH REVIEW	21-12-22
9	ISSUED FOR VCH REVIEW	21-09-08
8	ISSUED FOR ADP	21-07-14
7	ISSUED FOR VCH REVIEW	21-05-26
6	ISSUED FOR VCH REVIEW	21-03-26
5	ISSUED FOR REZONING	20-10-14
4	ISSUED FOR VCH REVIEW	20-10-07
3	ISSUED FOR REVIEW	20-09-18
2	ISSUED FOR REVIEW	20-07-10
1	ISSUED FOR REVIEW	20-06-29

REVISIONS

1550-EASTERN AVENUE

1550- Eastern Ave
North Vancouver, BC

Scale: AS SHOWN

Drawn: MR

Reviewed: KL

Project No. 06-705

LANDSCAPE SECTIONS

CONNECT LANDSCAPE ARCHITECTURE INC.
DOES NOT GUARANTEE THE EXISTENCE,
LOCATION, AND ELEVATION OF UTILITIES AND /
OR CONCEALED STRUCTURES AT THE PROJECT
SITE.

THE CONTRACTOR IS RESPONSIBLE FOR
DETERMINING THE EXISTENCE, LOCATION, AND
ELEVATION OF ALL UTILITIES AND / OR
CONCEALED STRUCTURES, AND IS
RESPONSIBLE FOR NOTIFYING THE
APPROPRIATE COMPANY, DEPARTMENT OR
PERSON(S) OF ITS INTENTION TO CARRY OUT ITS
OPERATIONS.

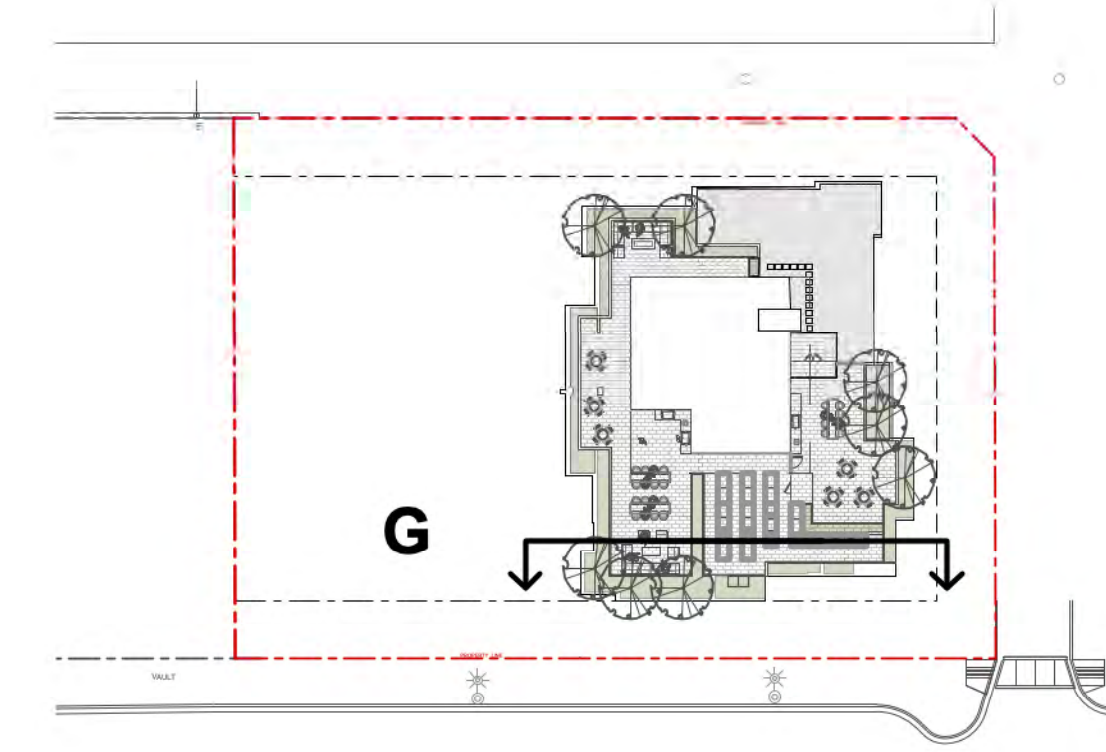

KEY PLAN - ROOF



PERIMETER PLANTER URBAN AGRICULTURE AREA PLANTER LOUNGE AREA PERIMETER PLANTER

G SECTION - ROOF AMENITY WEST
Scale: 1:50

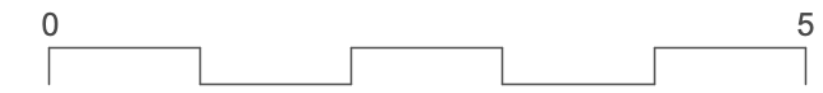

13	RE-ISSUED FOR REZONING	22-07-19
12	RE-ISSUED FOR REZONING	22-02-23
11	RE-ISSUED FOR REZONING	22-01-19
10	ISSUED FOR VCH REVIEW	21-12-22
9	ISSUED FOR VCH REVIEW	21-09-08
8	ISSUED FOR ADP	21-07-14
7	ISSUED FOR VCH REVIEW	21-05-26
6	ISSUED FOR VCH REVIEW	21-03-26
5	ISSUED FOR REZONING	20-10-14
4	ISSUED FOR VCH REVIEW	20-10-07
3	ISSUED FOR REVIEW	20-09-18
2	ISSUED FOR REVIEW	20-07-10
1	ISSUED FOR REVIEW	20-06-29

REVISIONS

1550-EASTERN AVENUE

1550- Eastern Ave
North Vancouver, BC

Scale: AS SHOWN

Drawn: MR

Reviewed: KL

Project No. 06-705

LANDSCAPE SECTIONS

CONNECT LANDSCAPE ARCHITECTURE INC. DOES NOT GUARANTEE THE EXISTENCE, LOCATION, AND ELEVATION OF UTILITIES AND / OR CONCEALED STRUCTURES AT THE PROJECT SITE.

THE CONTRACTOR IS RESPONSIBLE FOR DETERMINING THE EXISTENCE, LOCATION, AND ELEVATION OF ALL UTILITIES AND / OR CONCEALED STRUCTURES, AND IS RESPONSIBLE FOR NOTIFYING THE APPROPRIATE COMPANY, DEPARTMENT OR PERSON(S) OF ITS INTENTION TO CARRY OUT ITS OPERATIONS.

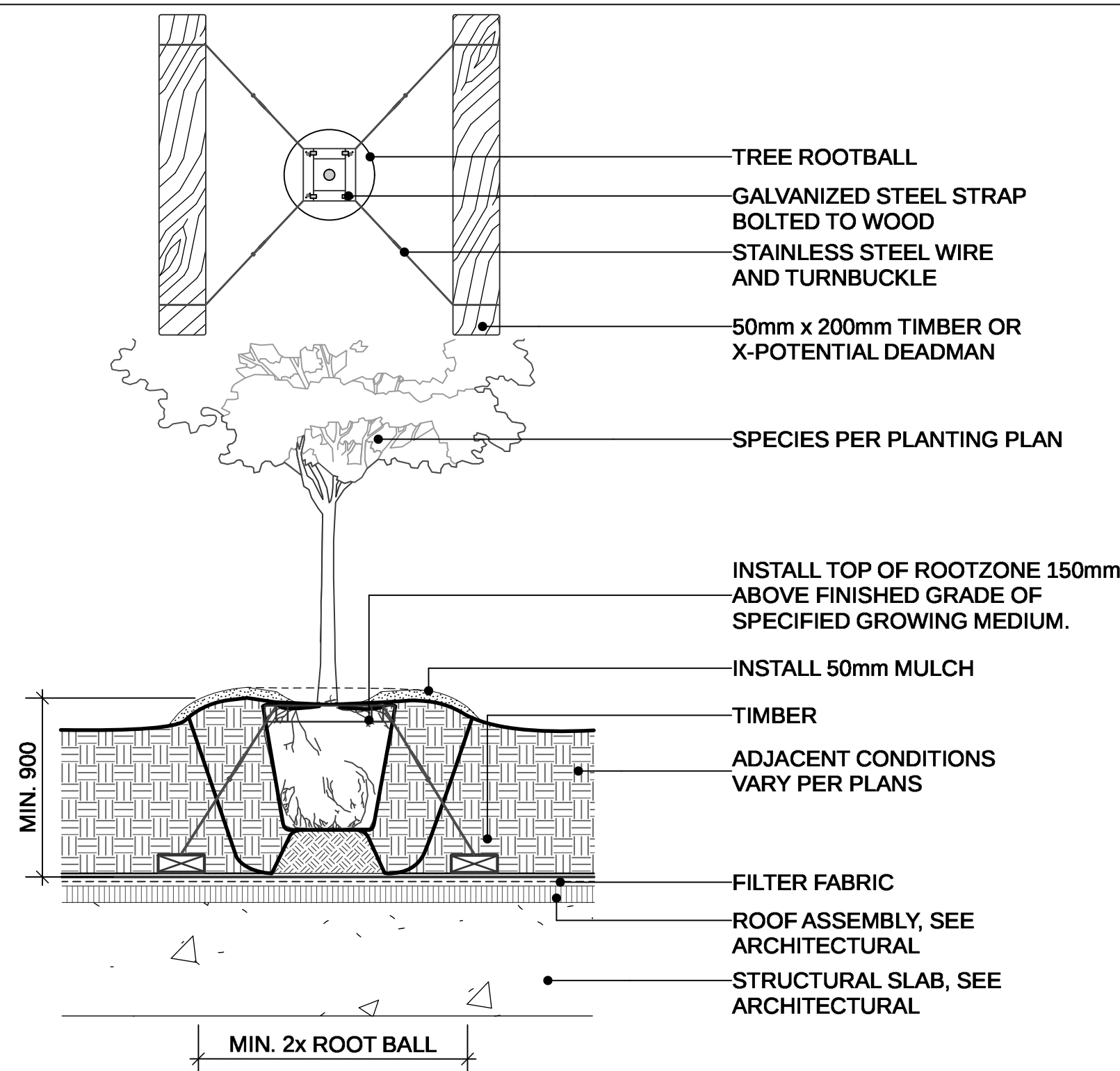

1 DECIDUOUS TREE PLANTING ON SLAB (TYPICAL)
SCALE 1:25

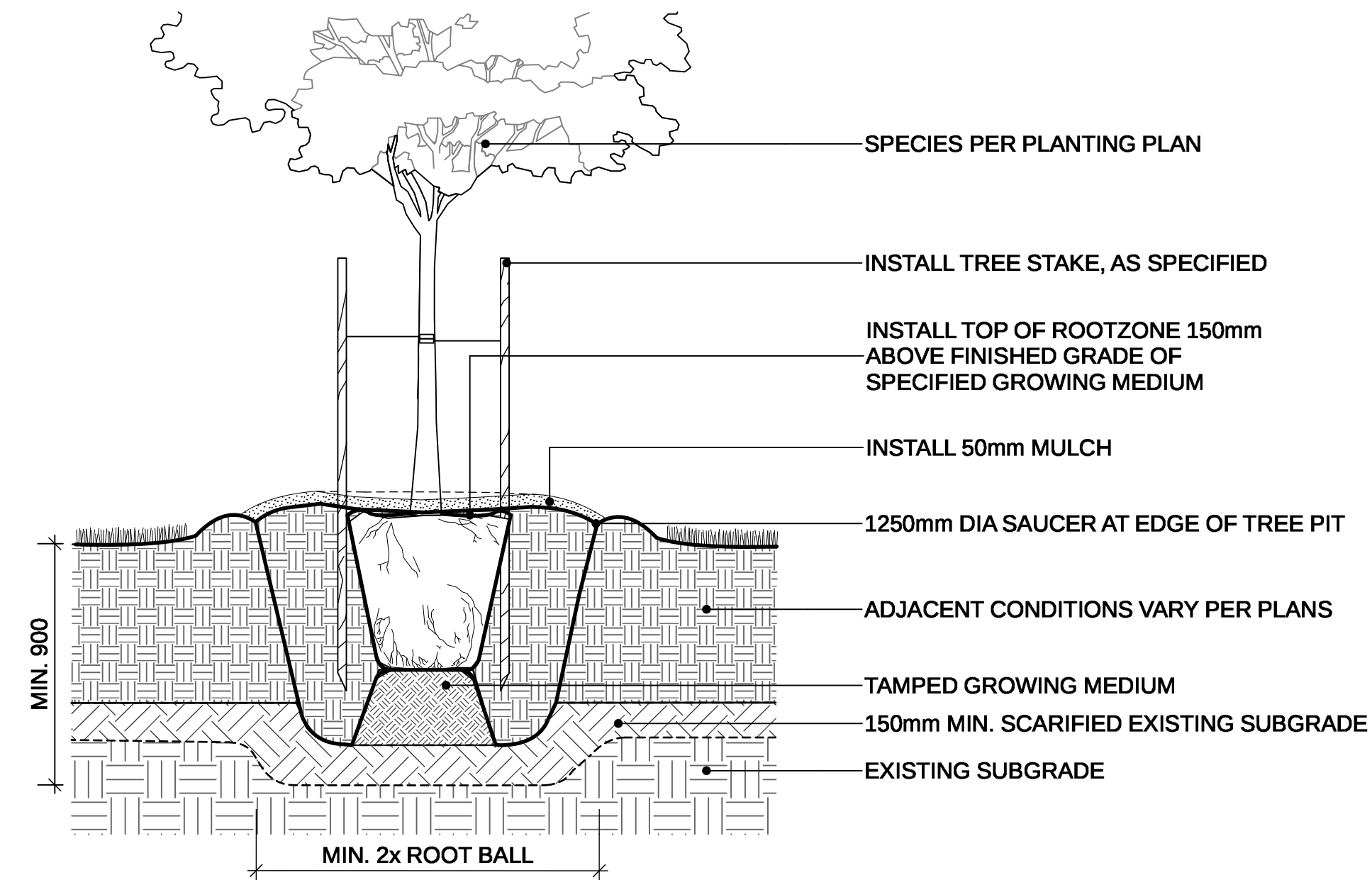

3 DECIDUOUS TREE PLANTING ON GRADE (TYPICAL)
SCALE 1:20

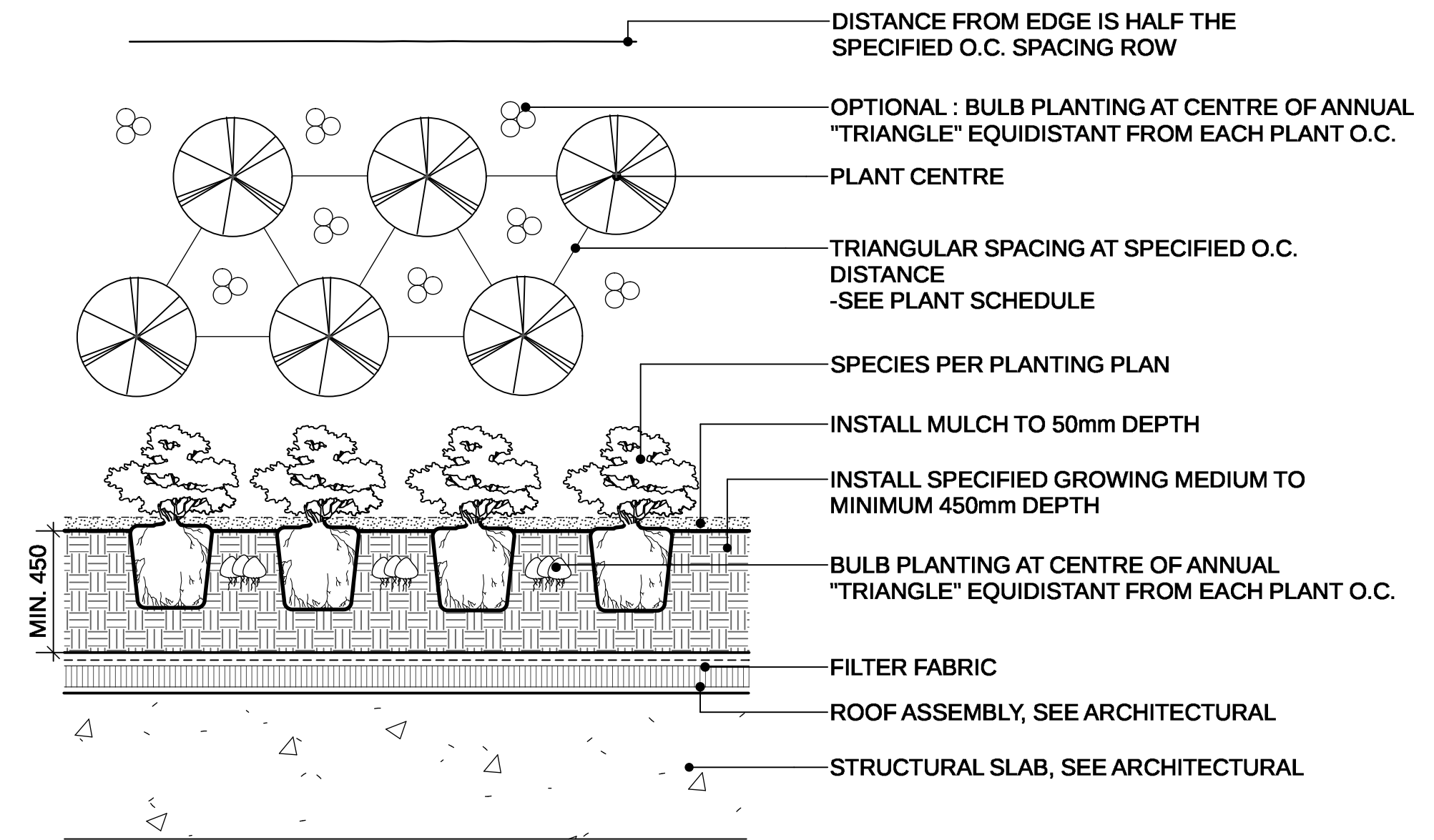

5 PLANTING ON SLAB (TYPICAL)
SCALE 1:20

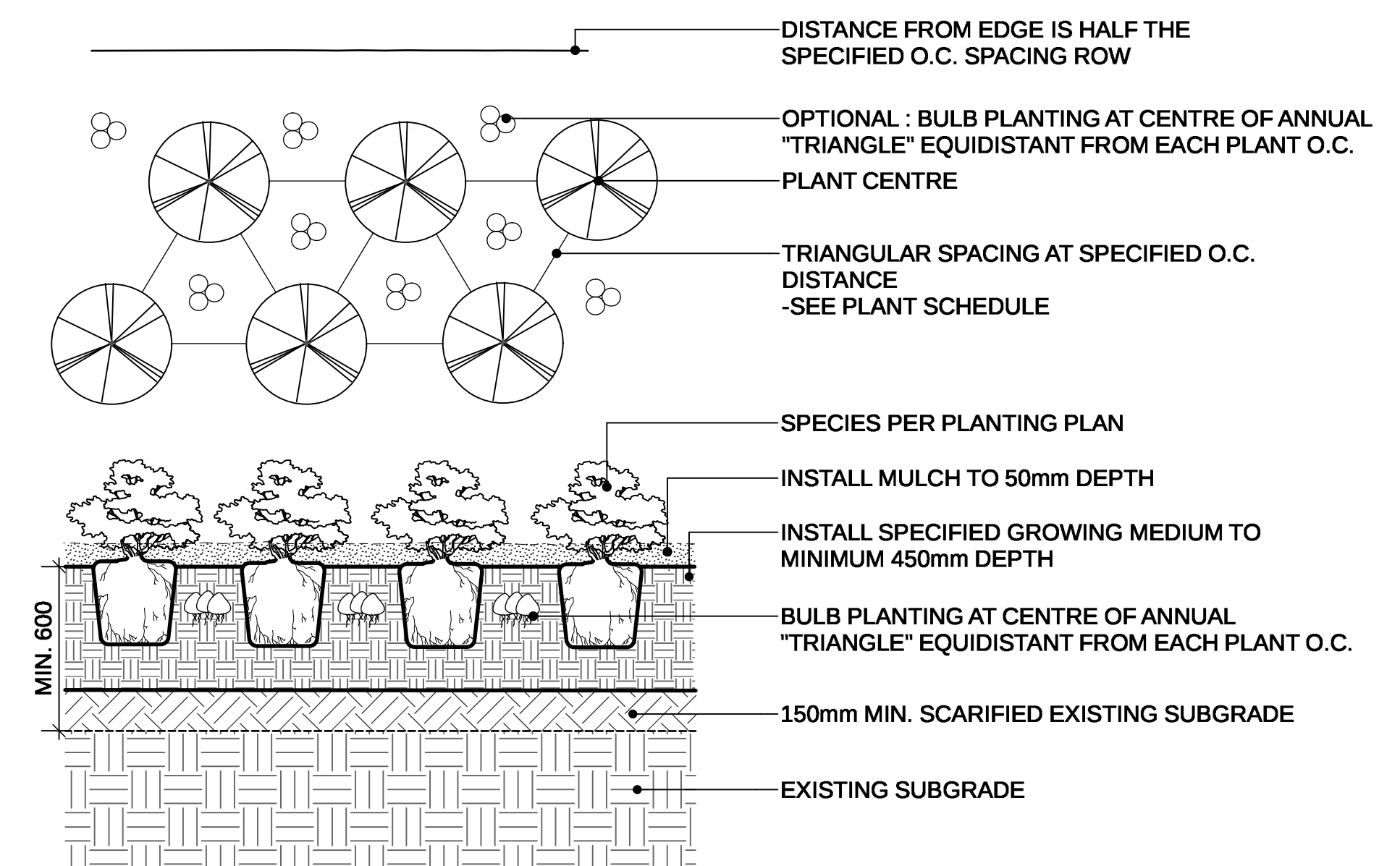

6 PLANTING ON GRADE (TYPICAL)
SCALE 1:20

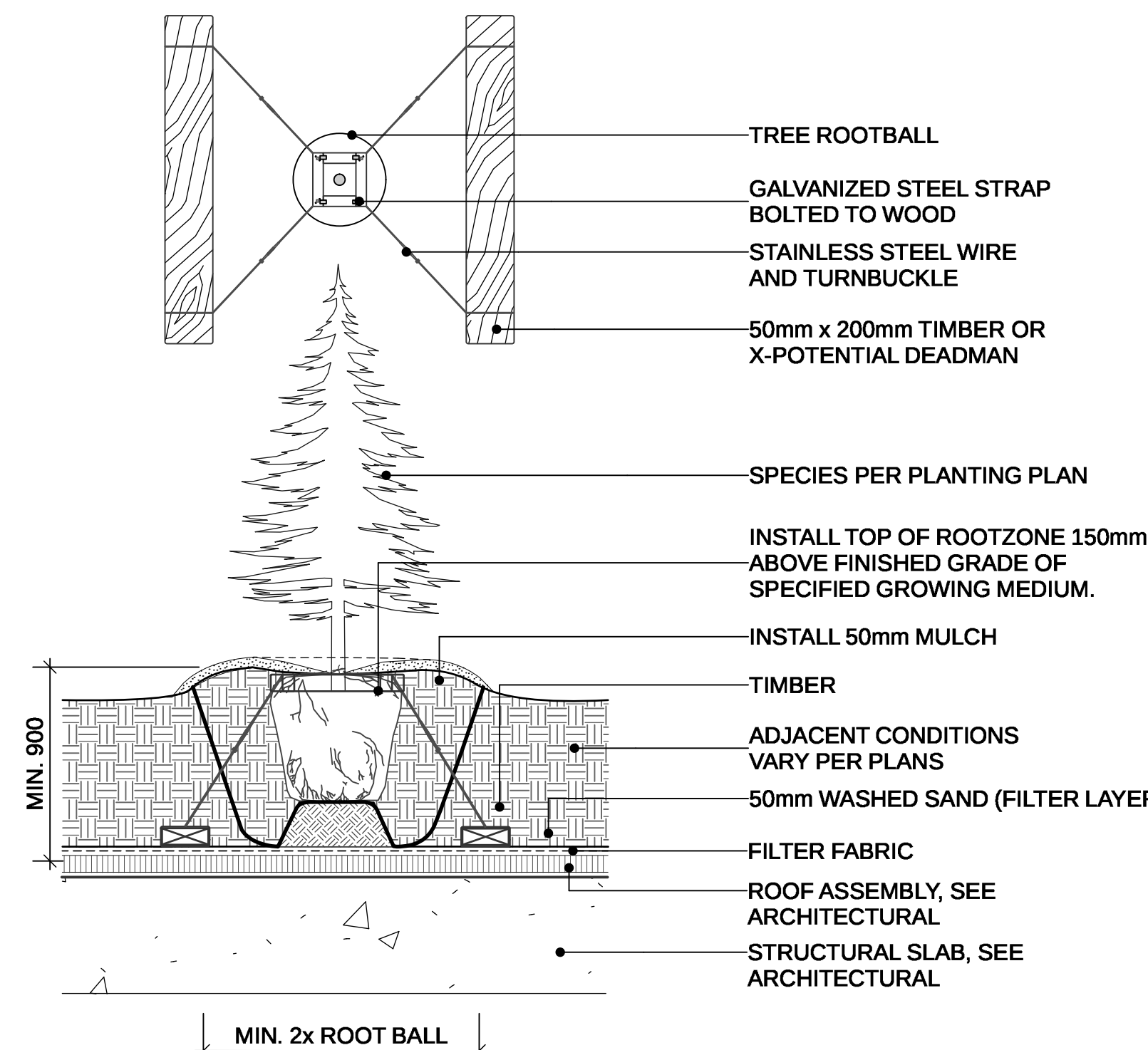

2 CONIFEROUS TREE PLANTING ON SLAB (TYPICAL)
SCALE 1:25

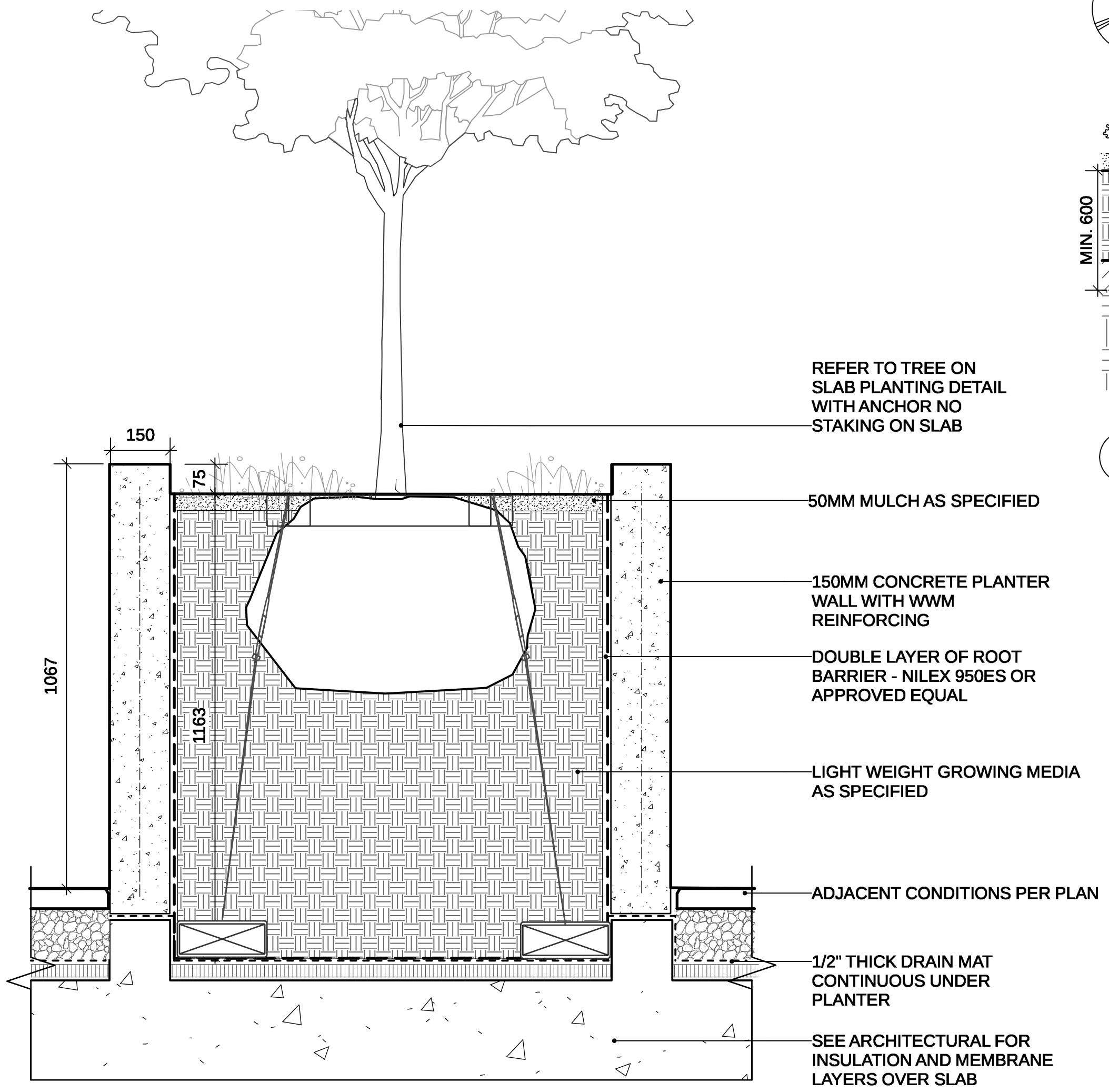

4 TYPICAL ON SLAB/ROOF PLANTER
Scale: 1:10

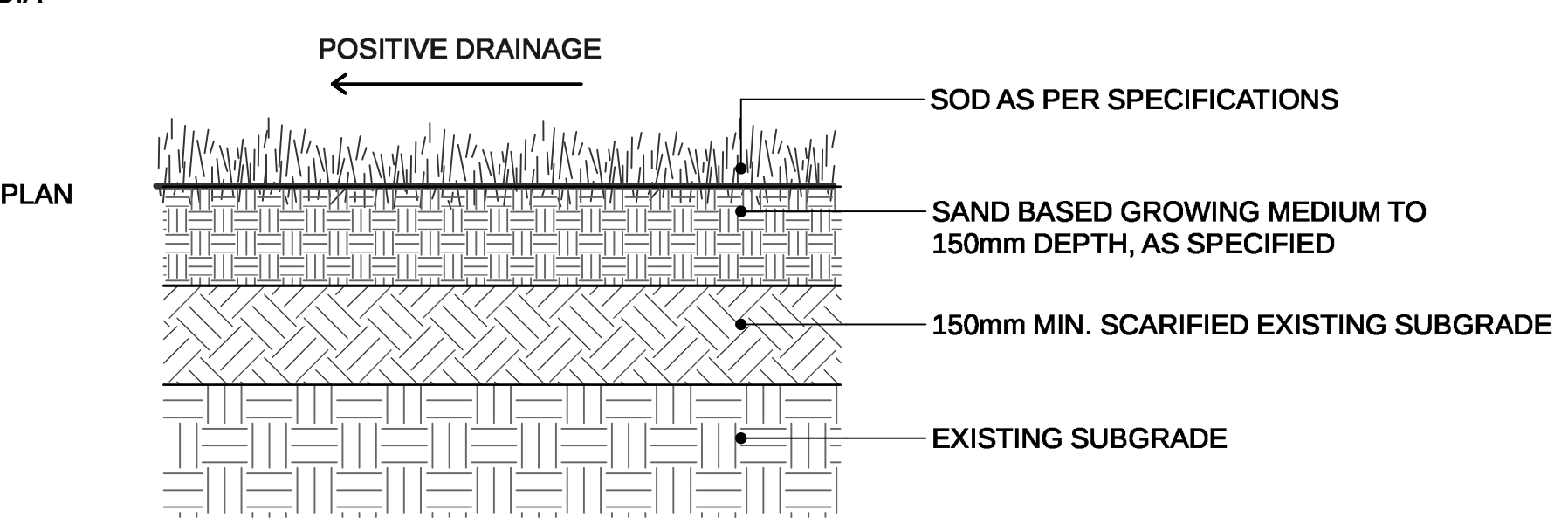

7 SOD LAWN ON GRADE (TYPICAL)
SCALE 1:10

13	RE-ISSUED FOR REZONING	22-07-19
12	RE-ISSUED FOR REZONING	22-02-23
11	RE-ISSUED FOR REZONING	22-01-19
10	ISSUED FOR VCH REVIEW	21-12-22
9	ISSUED FOR VCH REVIEW	21-09-08
8	ISSUED FOR ADP	21-07-14
7	ISSUED FOR VCH REVIEW	21-05-26
6	ISSUED FOR VCH REVIEW	21-03-26
5	ISSUED FOR REZONING	20-10-14
4	ISSUED FOR VCH REVIEW	20-10-07
3	ISSUED FOR REVIEW	20-09-18
2	ISSUED FOR REVIEW	20-07-10
1	ISSUED FOR REVIEW	20-06-29

REVISIONS

1550-EASTERN AVENUE

1550- Eastern Ave
North Vancouver, BC

Scale:	AS SHOWN
Drawn:	MR
Reviewed:	DS
Project No.	06-705

LANDSCAPE DETAILS

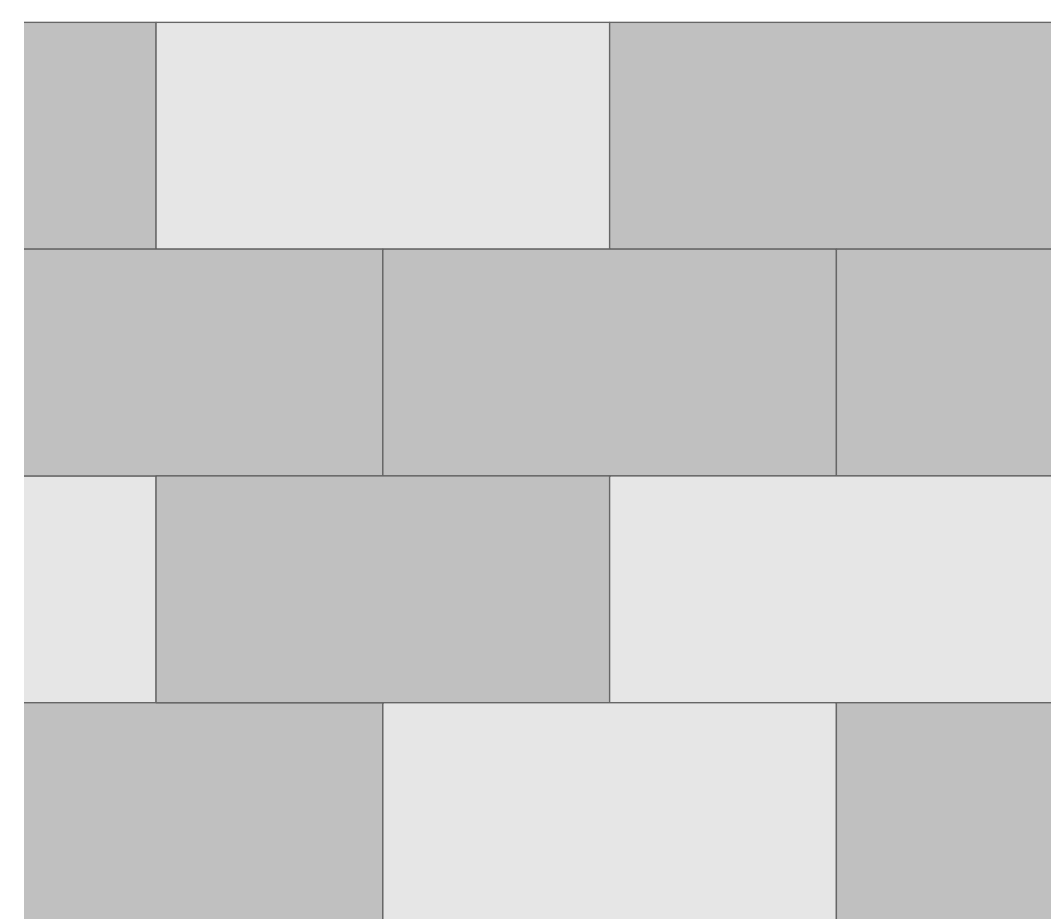

TYPE: HYDRAPRESSED SLAB, TEXADA
BY ABBOTSFORD CONCRETE
SIZE: 610mm x 305mm x 50mm
COLOR: MIX OF 60% CHARCOAL, 40% NATURAL
PATTERN: RUNNING BOND

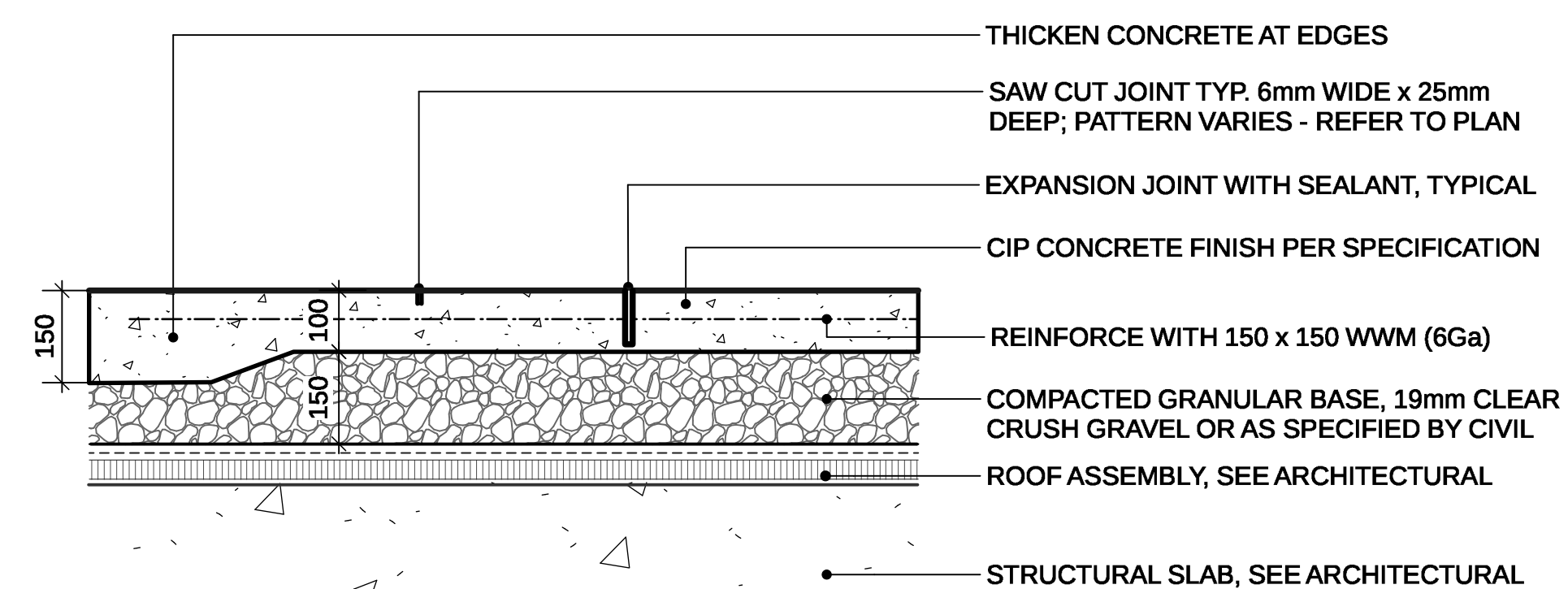

NOTES:
1. EXPANSION JOINTS 6m O.C. MAX, CONTROL JOINTS @ 1.5m O.C. ADJUST TO SUIT SITE LAYOUT PLAN.
2. ALL SCORELINES TO BE APPROVED BY LANDSCAPE ARCHITECT ON-SITE PRIOR TO INSTALLATION.
3. LIGHT SANDBLAST FINISH

4 CIP CONCRETE PAVING ON SLAB (TYPICAL)
SCALE 1:10

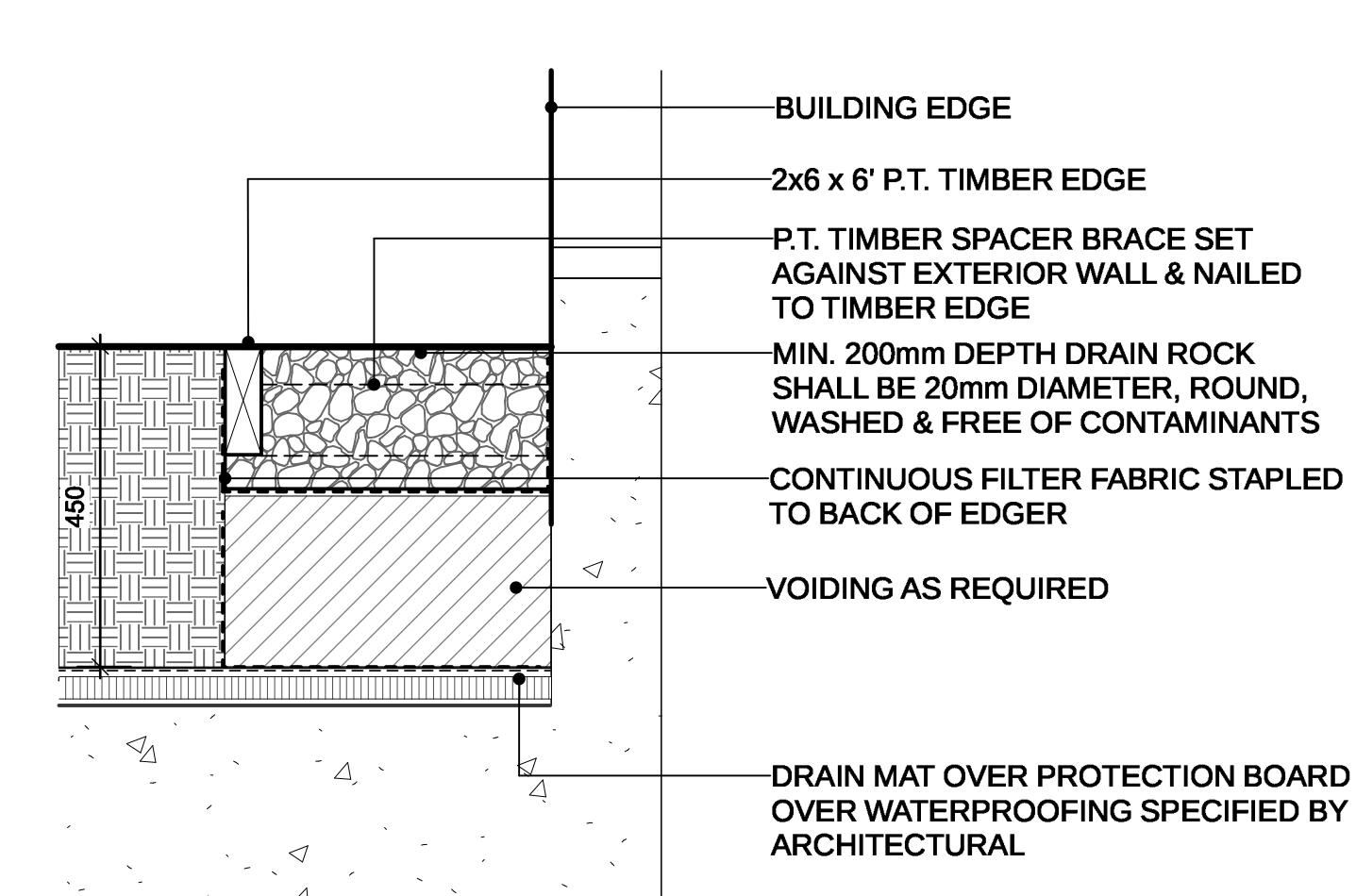

7 GRAVEL DRAIN STRIP ON SLAB
SCALE 1:10

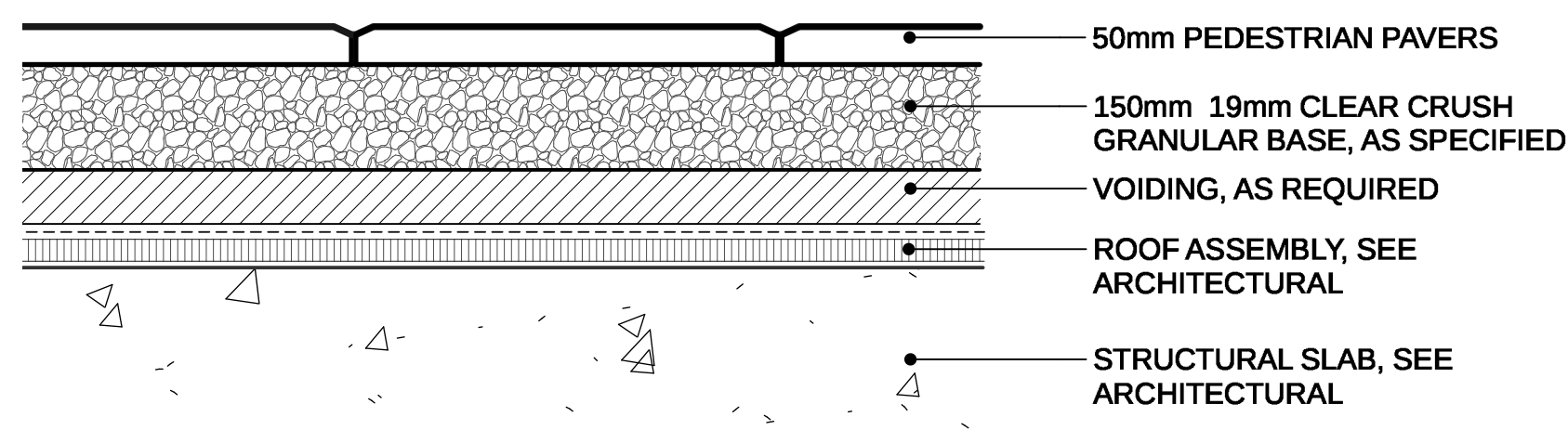

NOTE:
USE CONCRETE HIDDEN EDGE RESTRAINT WHEN PAVERS ARE NOT ADJACENT TO A SOLID EDGE CONDITION.

1 HYDRAPRESSED CONCRETE PAVERS ON SLAB ROOF DECKS
SCALE 1:10

TEXADA SERIES
SIZE: 610mm x 305mm x 50mm
COLOUR: NATURAL
BY: ABBOTSFORD CONCRETE PRODUCTS
(1.800.663.4091)

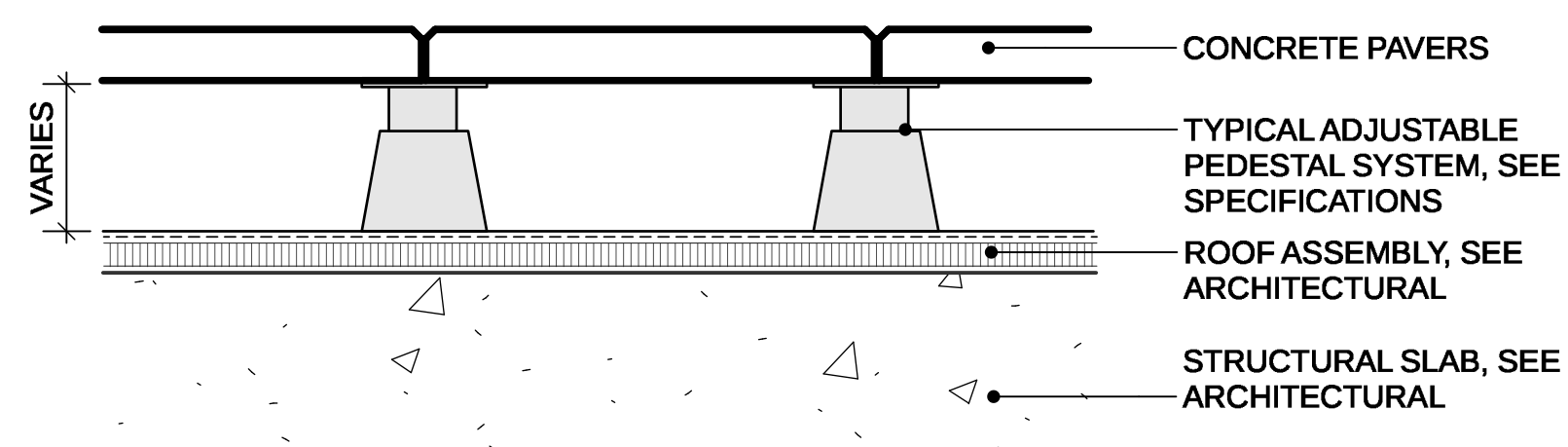

2 HYDRAPRESSED CONCRETE PAVERS ON PEDESTALS
Scale: 1:10

RUNNING BOND PATTERN

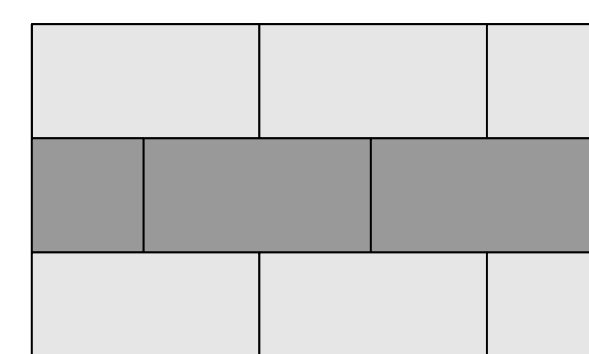

TYPE: CLASSIC STANDARD SERIES CALIFORNIA
SIZE: 301mm x 151mm x 60mm
PATTERN: RUNNING BOND
COLOR: CHARCOAL AND NATURAL
SUPPLIER: ABBOTSFORD CONCRETE PRODUCTS
VANCOUVER, BC
1.800.663.4091

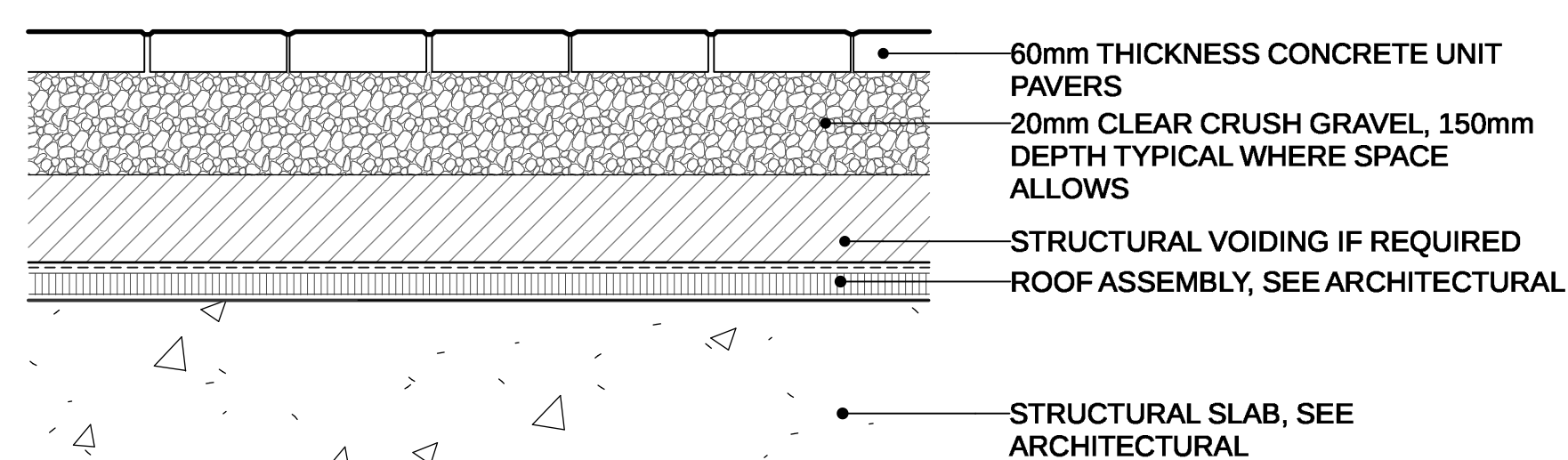

3 PEDESTRIAN UNIT PAVERS ON SLAB (TYPICAL)
Scale: 1:10

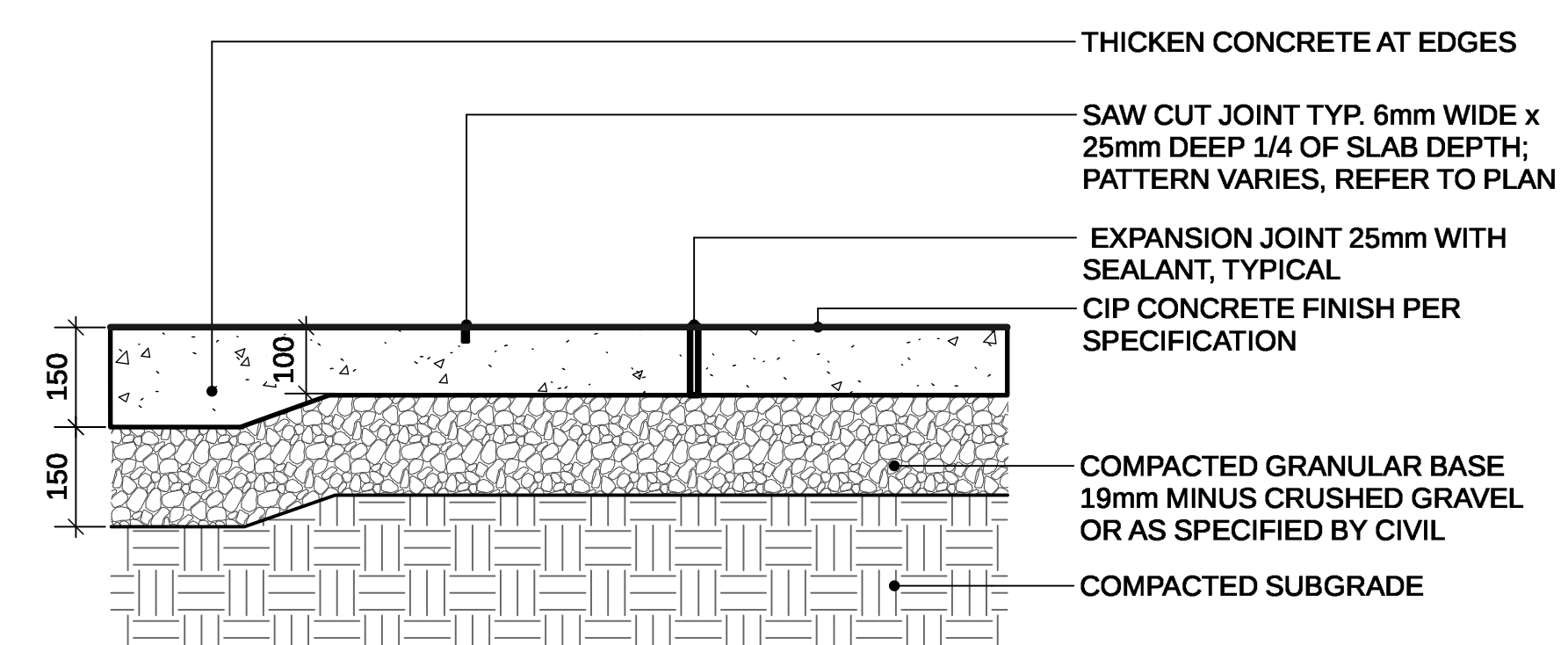

NOTES:
1. EXPANSION JOINTS 6m O.C. MAX, CONTROL JOINTS @ 1.5m O.C. ADJUST TO SUIT SITE LAYOUT PLAN.
2. ALL SCORELINES TO BE APPROVED BY LANDSCAPE ARCHITECT ON-SITE PRIOR TO INSTALLATION.
3. LIGHT SANDBLAST FINISH

5 CIP CONCRETE PAVING ON GRADE (TYPICAL)
SCALE 1:10

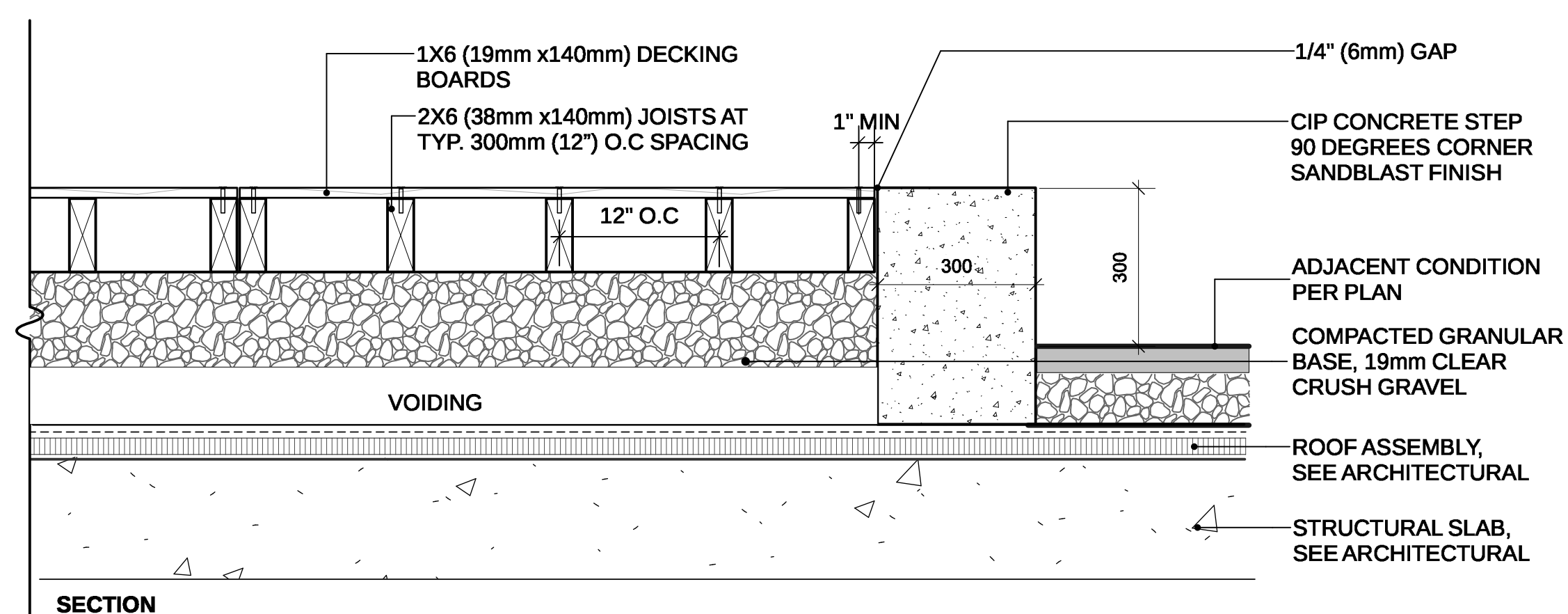

SECTION

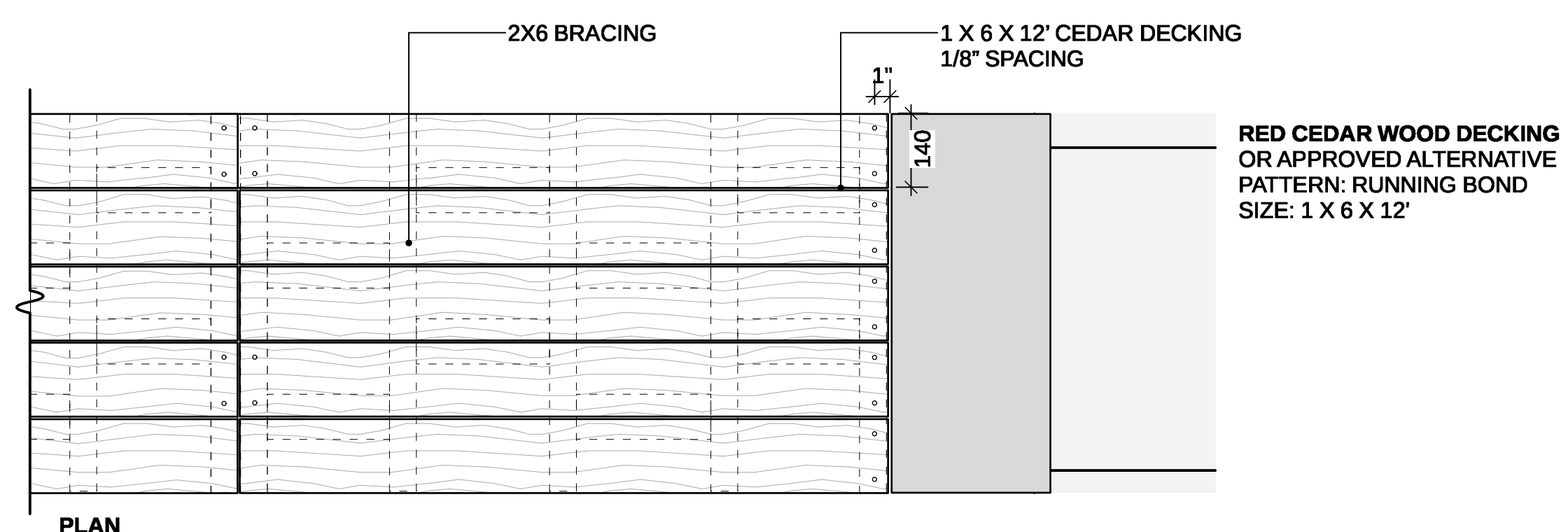

PLAN

6 CEDAR DECKIGN ON SLAB
SCALE 1:10

13	RE-ISSUED FOR REZONING	22-07-19
12	RE-ISSUED FOR REZONING	22-02-23
11	RE-ISSUED FOR REZONING	22-01-19
10	ISSUED FOR VCH REVIEW	21-12-22
9	ISSUED FOR VCH REVIEW	21-09-08
8	ISSUED FOR ADP	21-07-14
7	ISSUED FOR VCH REVIEW	21-05-26
6	ISSUED FOR VCH REVIEW	21-03-26
5	ISSUED FOR REZONING	20-10-14
4	ISSUED FOR VCH REVIEW	20-10-07
3	ISSUED FOR REVIEW	20-09-18
2	ISSUED FOR REVIEW	20-07-10
1	ISSUED FOR REVIEW	20-06-29

REVISIONS

1550-EASTERN AVENUE

1550- Eastern Ave
North Vancouver, BC

Scale: AS SHOWN

Drawn: MR

Reviewed: DS

Project No. 06-705

LANDSCAPE DETAILS

CONNECT LANDSCAPE ARCHITECTURE INC. DOES NOT GUARANTEE THE EXISTENCE, LOCATION, AND ELEVATION OF UTILITIES AND / OR CONCEALED STRUCTURES AT THE PROJECT SITE.

THE CONTRACTOR IS RESPONSIBLE FOR DETERMINING THE EXISTENCE, LOCATION, AND ELEVATION OF ALL UTILITIES AND / OR CONCEALED STRUCTURES, AND IS RESPONSIBLE FOR NOTIFYING THE APPROPRIATE COMPANY, DEPARTMENT OR PERSON(S) OF ITS INTENTION TO CARRY OUT ITS OPERATIONS.

MLB970-W BENCH BY MAGLIN SITE FURNITURE (1-800-716-5506)
DIMENSIONS: 84.2cm HEIGHT x 177.8cm LENGTH x 58.4cm DEPTH
POWDERCOAT COLOUR: GUNMETAL, IPE WOOD

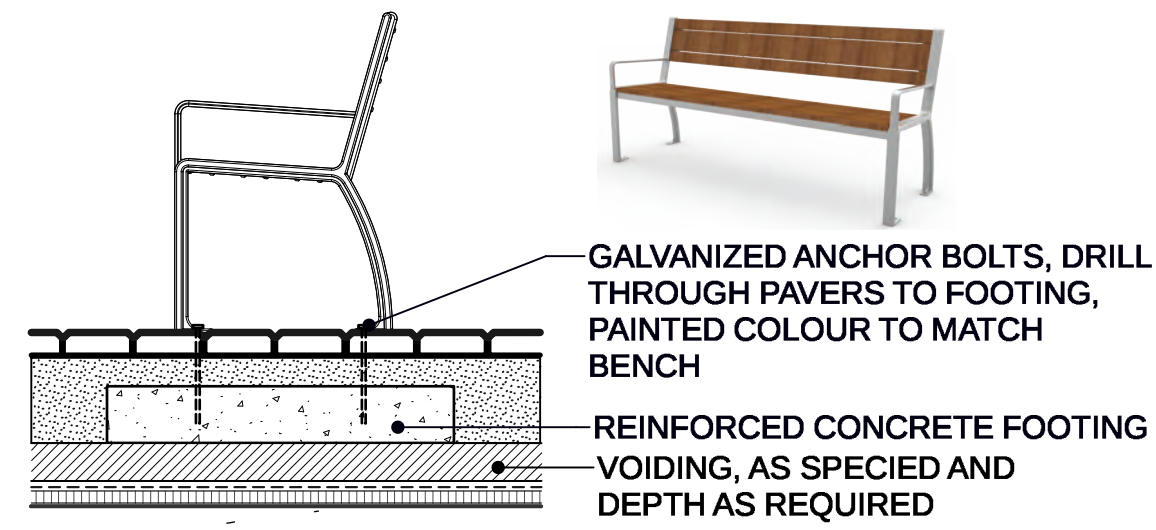

NOTE:
PER SUPPLIER FOR SPECIFICATIONS AND INSTALLATIONS.

1 BACKED BENCH TYPE 1
SCALE 1:10

MBR350-5-S BICYCLE RACK BY MAGLIN SITE FURNITURE (1-800-716-5506)
DIMENSIONS: 60.48cm HEIGHT x 94.62cm LENGTH x 62.56cm DIAMETER
POWDERCOAT COLOUR: GUNMETAL

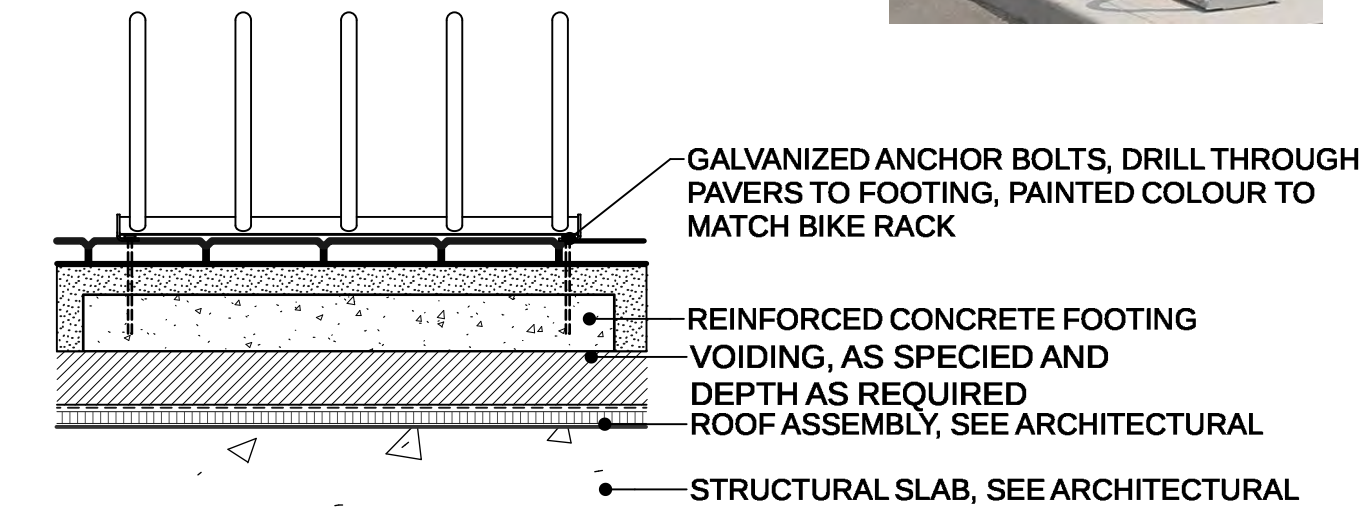

NOTE:
PER SUPPLIER FOR SPECIFICATIONS AND INSTALLATIONS.

2 BIKE RACK
SCALE 1:10

MODEL: ALUMINUM PLANTER
SIZE: 750mm H x 915mm L x 2420mm W
COLOUR: PEWTER
BY: GREEN THEORY (604 475-7002)

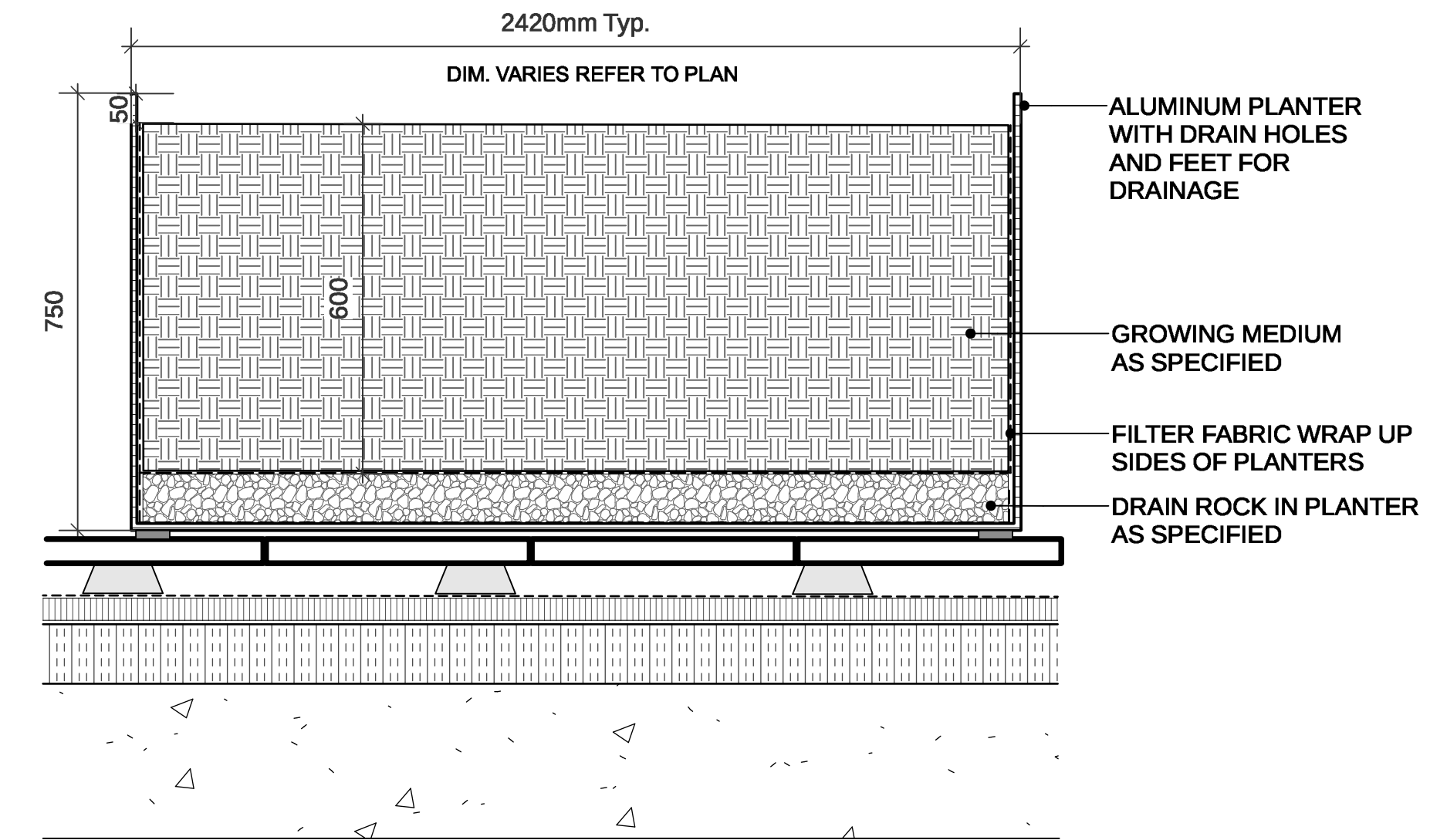

3 ALUMINUM URBAN AGRICULTURE PLANTER ON SLAB
SCALE 1:10

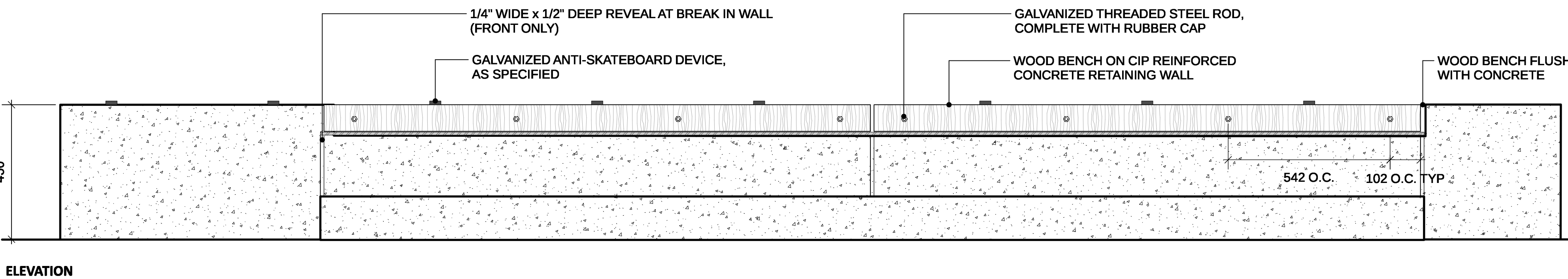
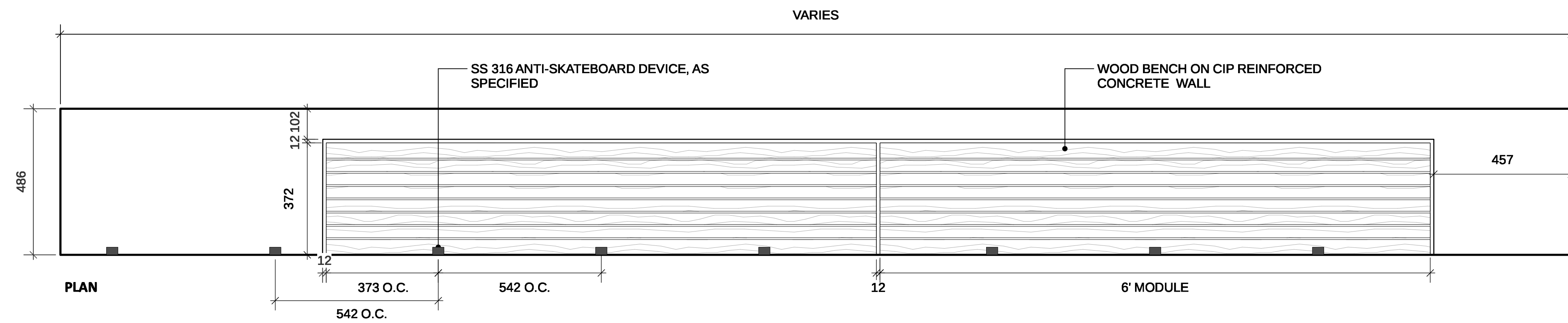

4 CIP CONCRETE SEATWALL WITH BENCH TOP
SCALE 1:10

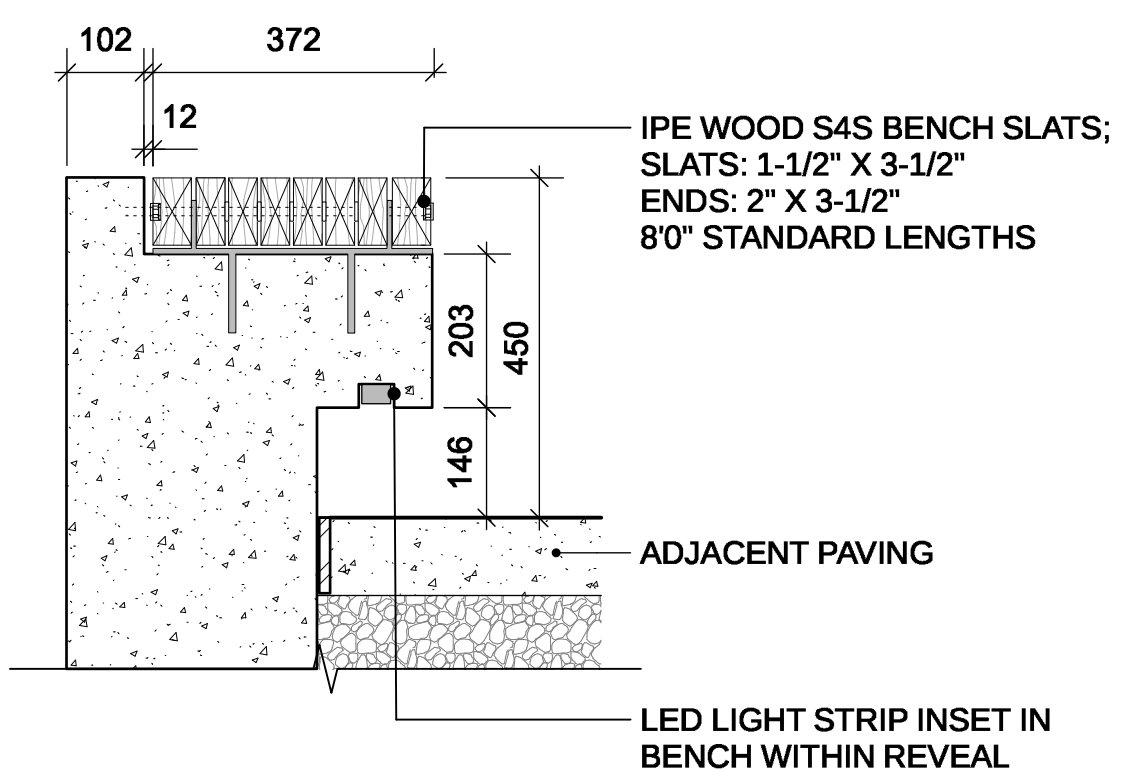
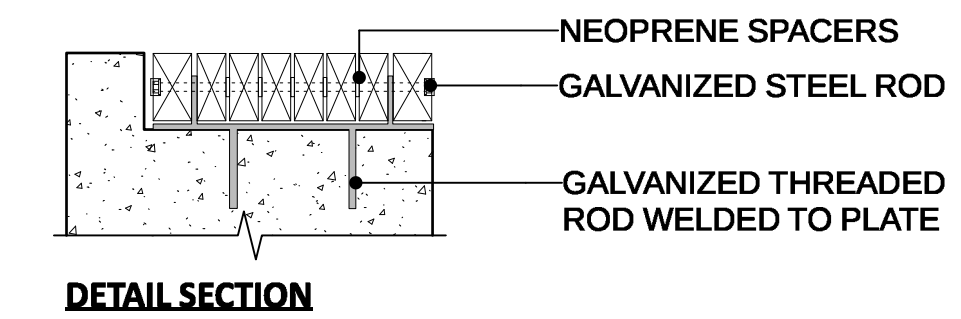

13	RE-ISSUED FOR REZONING	22-07-19
12	RE-ISSUED FOR REZONING	22-02-23
11	RE-ISSUED FOR REZONING	22-01-19
10	ISSUED FOR VCH REVIEW	21-12-22
9	ISSUED FOR VCH REVIEW	21-09-08
8	ISSUED FOR ADP	21-07-14
7	ISSUED FOR VCH REVIEW	21-05-26
6	ISSUED FOR VCH REVIEW	21-03-26
5	ISSUED FOR REZONING	20-10-14
4	ISSUED FOR VCH REVIEW	20-10-07
3	ISSUED FOR REVIEW	20-09-18
2	ISSUED FOR REVIEW	20-07-10
1	ISSUED FOR REVIEW	20-06-29

REVISIONS

1550-EASTERN AVENUE

1550- Eastern Ave
North Vancouver, BC

Scale: AS SHOWN
Drawn: MR
Reviewed: DS
Project No. 06-705

LANDSCAPE DETAILS

QUADRA

-60in + 72in-



DIMENSIONS

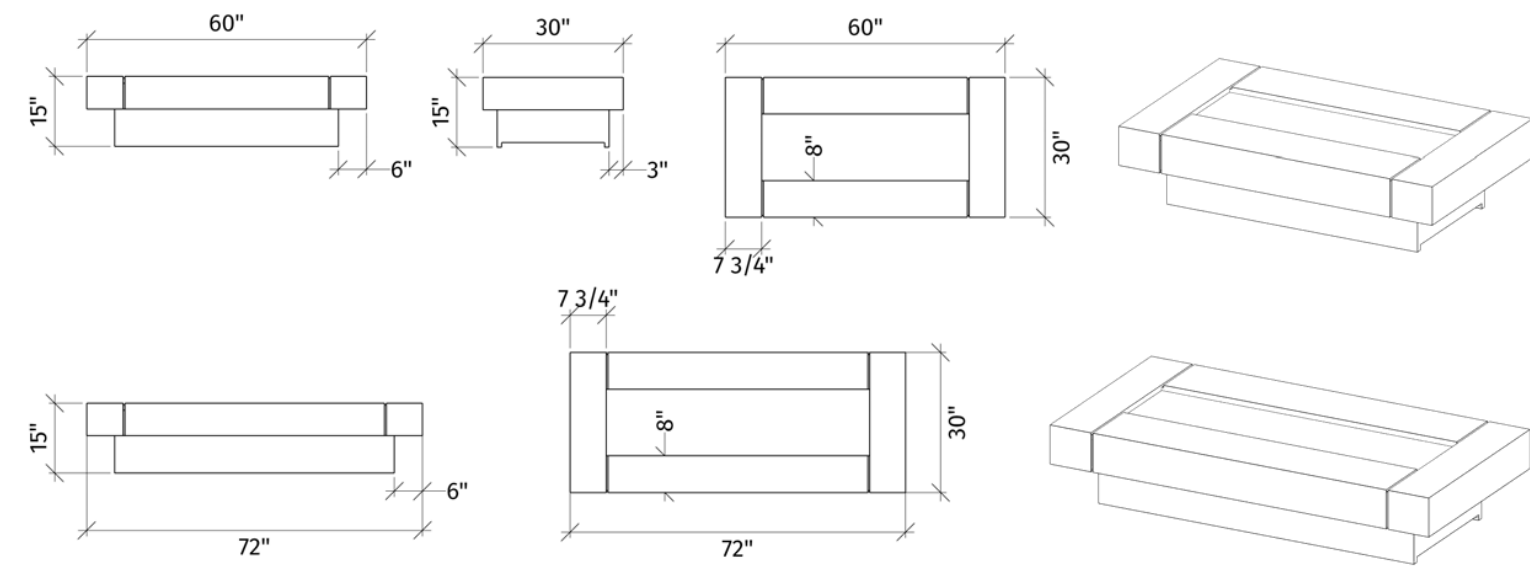

COMFORTABLE LIVING



Designed to enhance outdoor entertainment areas, the highly expressive **Quadra** fire table helps define the modern patio.

COLOUR:
LONDON FOG

- QUADRA PACKAGE INCLUDES:**
- CONCRETE FIREPIT TOP
 - CONCRETE FIREPIT BASE
 - MANUAL LIT NG/LP BURNER
 - LAVA ROCK
- Firepits ship fully sealed
Accessories available



Please contact us at 1-604-278-4939 with any questions. Our experienced team can assist you with product information, installation and design recommendations. We also encourage you to explore our website at www.dreamcastfirepits.com

1 GAS FIRE PLACE AMENITY AREA



3 BOLLARD

PROVIDER: DAL'S
MODEL: LEDPATH003/LEDPATH004
COLOUR: SILVER GREY
AVAILABLE THROUGH SLS LIGHT
RESOURCE 778-329 9439



6 RECESSED WALL LIGHT

PROVIDER: MP LIGHTING
MODEL: L46 LED LIGHT
COLOUR: ANODIZED ALUMINUM FINISH
CONTACT: 604.708.1184



7 EXTERIOR WALL MOUNT LIGHT

PROVIDER: MP LIGHTING
MODEL: L721 LED LIGHT
COLOUR: ANODIZED ALUMINUM FINISH
CONTACT: 604.708.1184



8 TRELLIS LIGHT

PROVIDER: TEGAN
MODEL: EXTON MONO - DIRECT MOUNT - GEMS ANODIZED ALUMINUM
AVAILABLE THROUGH SLS LIGHT
RESOURCE 778-329 9439

NOTES:

1. SELF CLOSING GATE AND LATCH
2. USE PREFABRICATED GATEBOX FOR LATCH ASSEMBLY AND KEY
3. ALL METAL ALUMINUM WITH BLACK CHARCOAL POWDERCOAT FINISH (TO BE FACTORY APPLIED).
4. ALL WELDED CONSTRUCTION. GRIND ALL WELDS SMOOTH.
5. PROVIDE SHOP DRAWINGS OF GATE AND FENCE FOR APPROVAL.

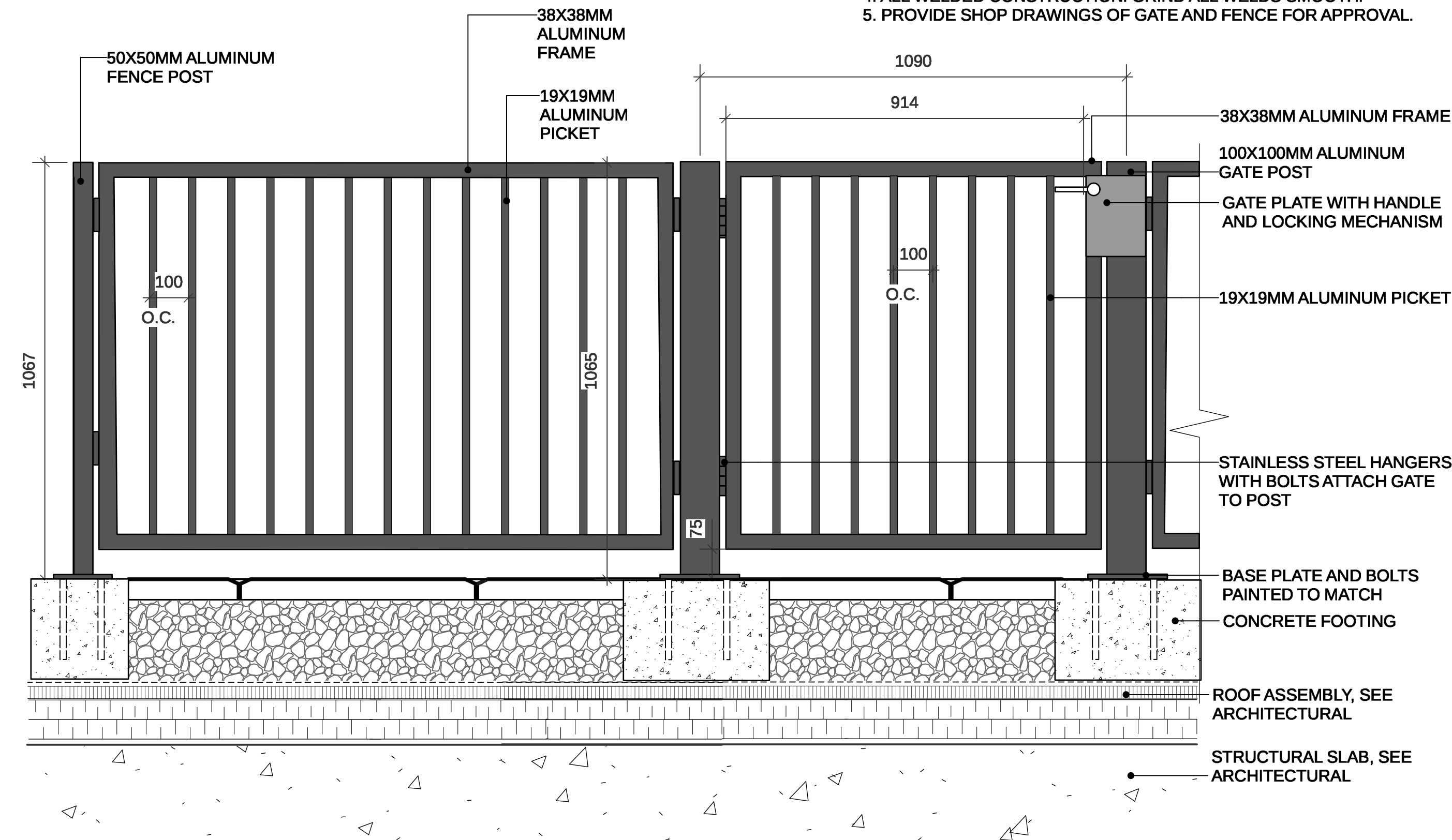

4 METAL FENCE AND GATE ON SLAB SCALE 1:10

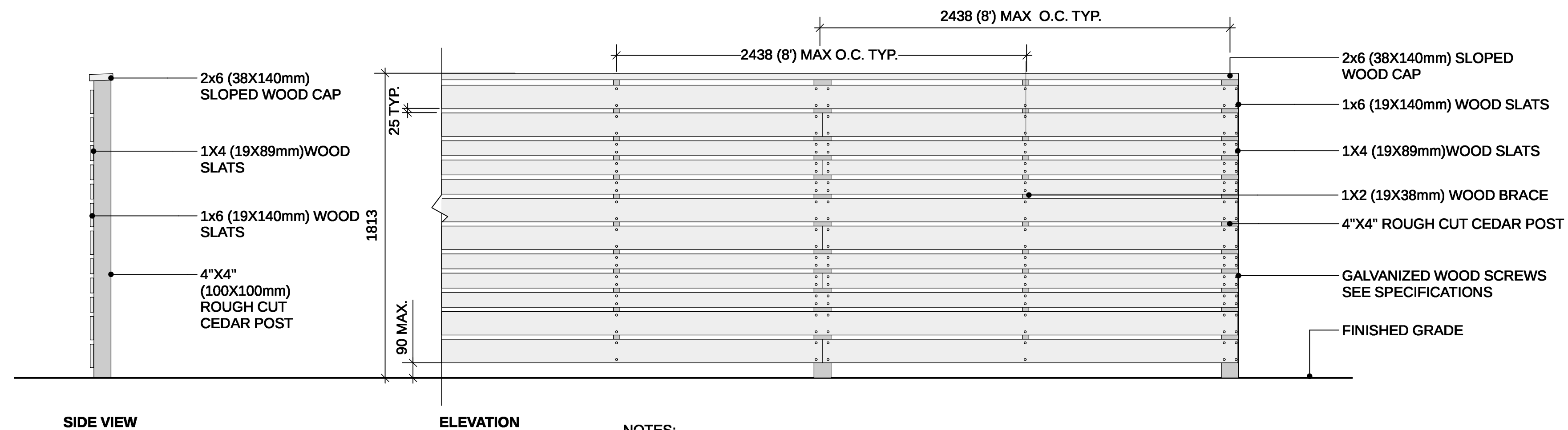

5 TIMBER FENCE @ DAYCARE SCALE 1:10

NOTES:

1. ALL WOOD SLATS TO BE TO BE CEDAR STRUCTURAL SELECT UNTREATED CONTINUOUS STRUCTURAL WOOD.
2. ALL WOOD TO BE CEDAR, NO PRESSURE TREATED WOOD.
3. ALL WOOD TO BE SANDED.

2305 Hemlock St Vancouver BC V6H2V1
T 604 681 3303 F 604 681 3307
www.connectla.ca

CONNECT LANDSCAPE ARCHITECTURE INC.
DOES NOT GUARANTEE THE EXISTENCE,
LOCATION, AND ELEVATION OF UTILITIES AND /
OR CONCEALED STRUCTURES AT THE PROJECT
SITE.

THE CONTRACTOR IS RESPONSIBLE FOR
DETERMINING THE EXISTENCE, LOCATION, AND
ELEVATION OF ALL UTILITIES AND / OR
CONCEALED STRUCTURES, AND IS
RESPONSIBLE FOR NOTIFYING THE
APPROPRIATE COMPANY, DEPARTMENT OR
PERSON(S) OF ITS INTENTION TO CARRY OUT ITS
OPERATIONS.

13	RE-ISSUED FOR REZONING	22-07-19
12	RE-ISSUED FOR REZONING	22-02-23
11	RE-ISSUED FOR REZONING	22-01-19
10	ISSUED FOR VCH REVIEW	21-12-22
9	ISSUED FOR VCH REVIEW	21-09-08
8	ISSUED FOR ADP	21-07-14
7	ISSUED FOR VCH REVIEW	21-05-26
6	ISSUED FOR VCH REVIEW	21-03-26
5	ISSUED FOR REZONING	20-10-14
4	ISSUED FOR VCH REVIEW	20-10-07
3	ISSUED FOR REVIEW	20-09-18
2	ISSUED FOR REVIEW	20-07-10
1	ISSUED FOR REVIEW	20-06-29

REVISIONS

1550-EASTERN AVENUE

1550- Eastern Ave
North Vancouver, BC

Scale: AS SHOWN

Drawn: MR

Reviewed: DS

Project No. 06-705

LANDSCAPE DETAILS

CONNECT LANDSCAPE ARCHITECTURE INC. DOES NOT GUARANTEE THE EXISTENCE, LOCATION, AND ELEVATION OF UTILITIES AND / OR CONCEALED STRUCTURES AT THE PROJECT SITE.

THE CONTRACTOR IS RESPONSIBLE FOR DETERMINING THE EXISTENCE, LOCATION, AND ELEVATION OF ALL UTILITIES AND / OR CONCEALED STRUCTURES, AND IS RESPONSIBLE FOR NOTIFYING THE APPROPRIATE COMPANY, DEPARTMENT OR PERSON(S) OF ITS INTENTION TO CARRY OUT ITS OPERATIONS.

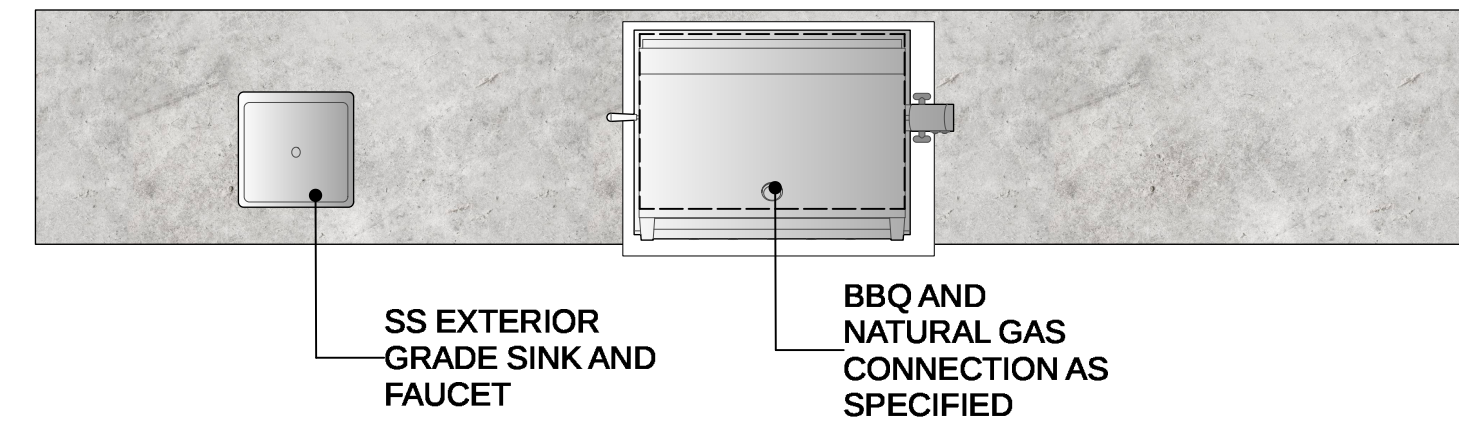

PLAN VIEW - BBQ AND COUNTER

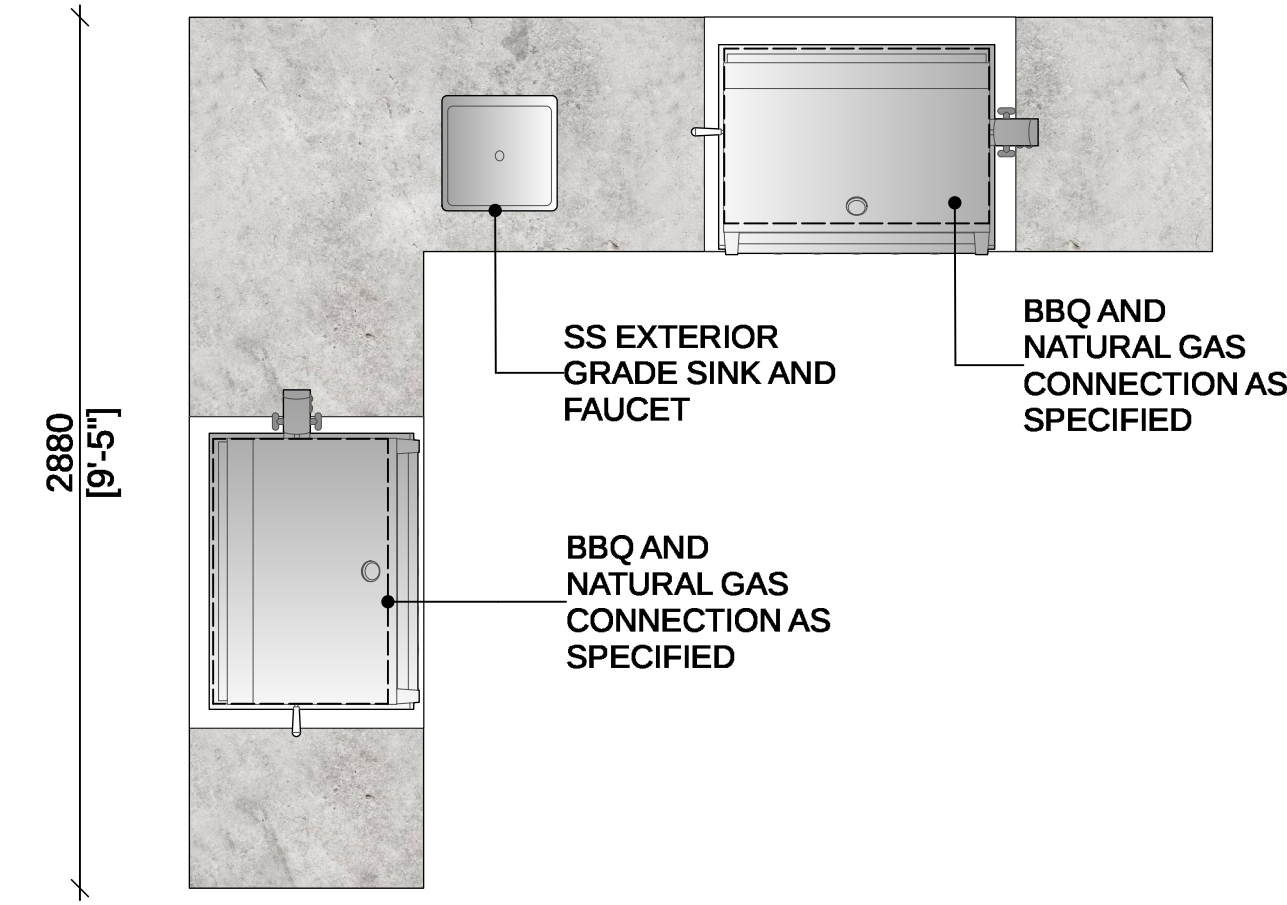

PLAN VIEW - BBQ AND COUNTER

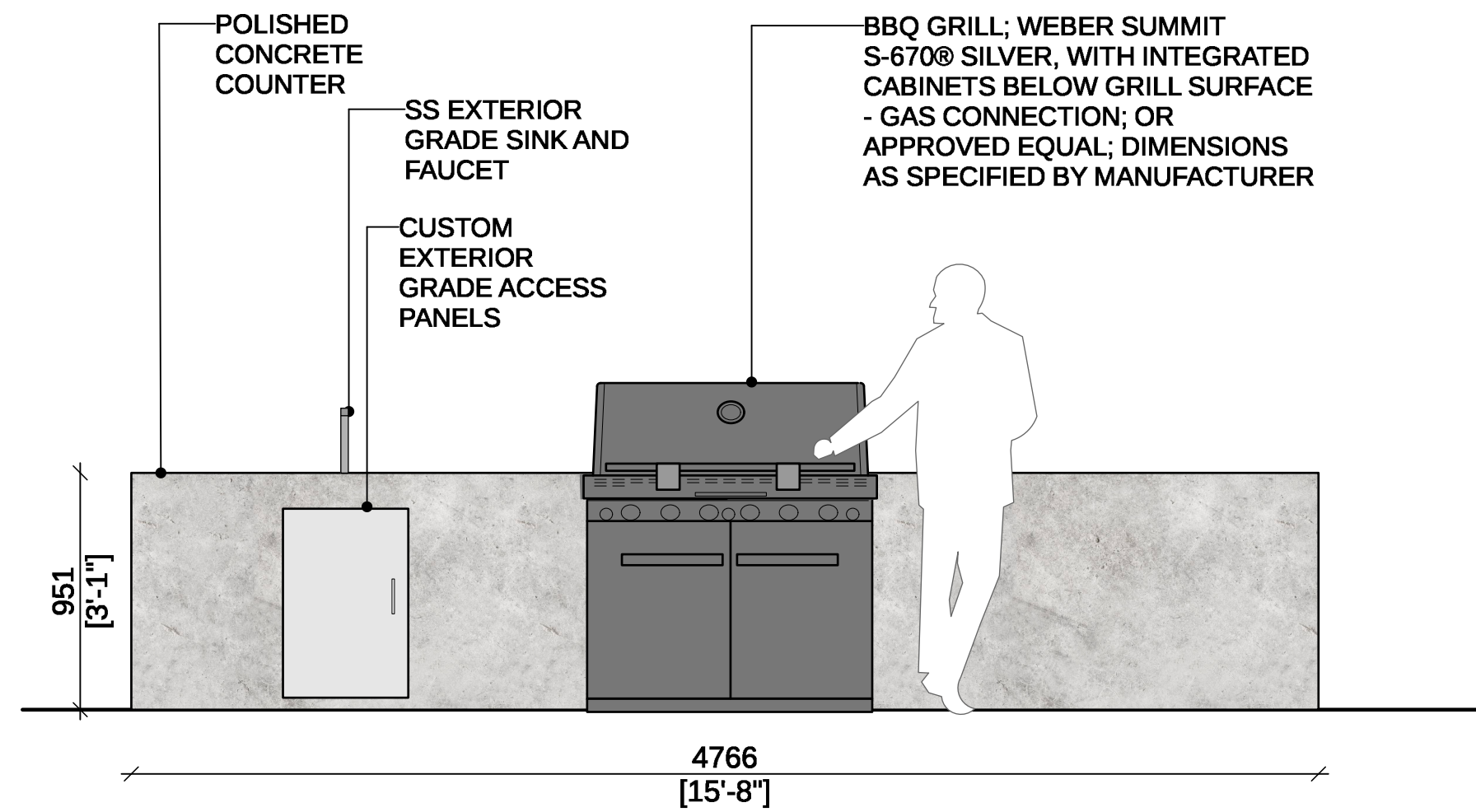

- NOTE:
1. CONTRACTOR TO PROVIDE SHOP DRAWINGS FOR REVIEW AND APPROVAL.
 2. MANUAL SHUT OFF VALVE TO BE PROVIDED FOR GAS BARBEQUE CONNECTION.
 3. BARBEQUE GRILL TO BE INSTALLED AS PER MANUFACTURES INSTRUCTION.
 4. REFER TO MECHANICAL DRAWINGS FOR SINK AND PLUMBING

ELEVATION

1 BBQ AND SINK WITH COUNTER SOUTH
Scale: 1:25



BBQ DIMENSIONS:
DEPTH: 30.5"
HEIGHT: 52"
WIDTH: 47"

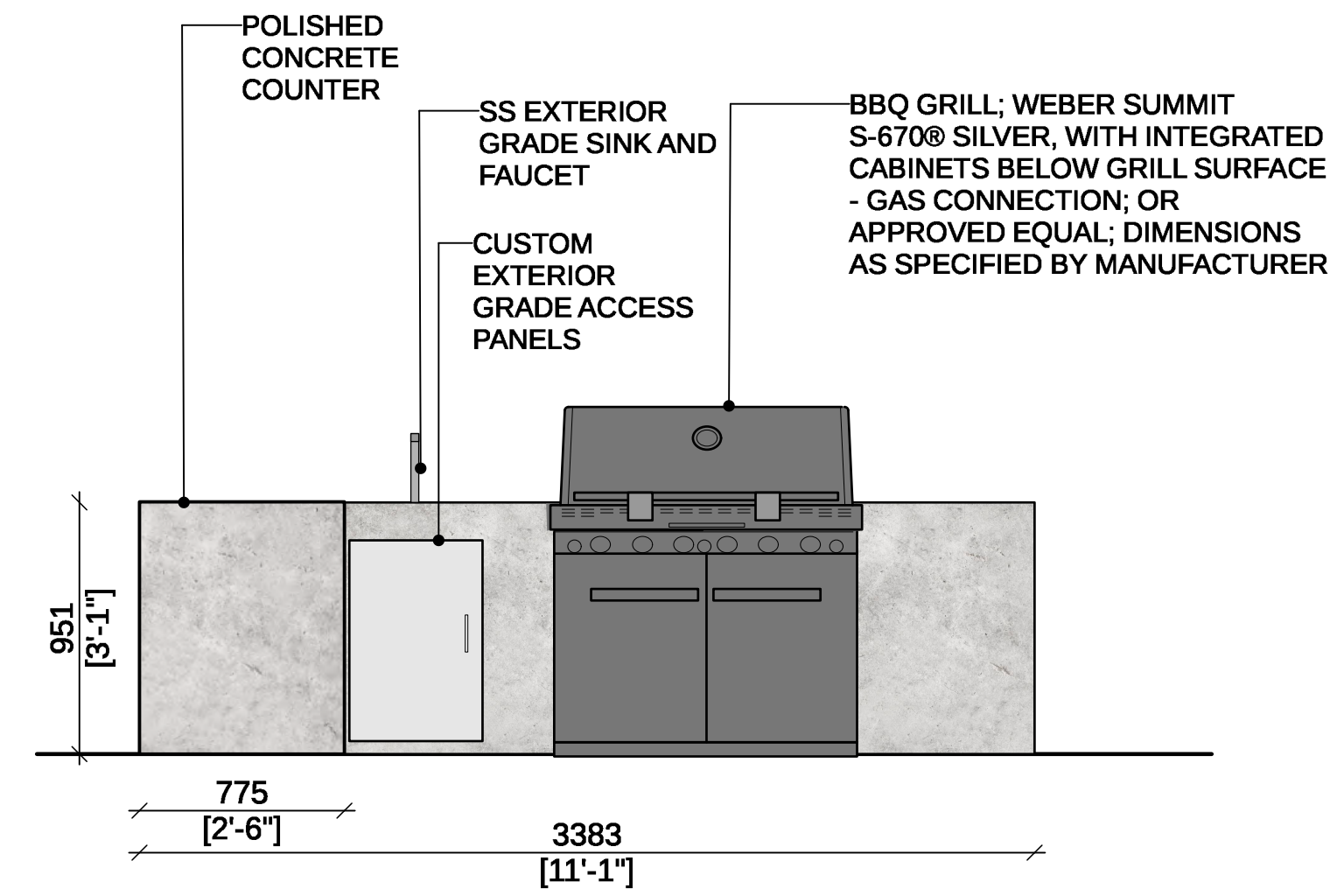

- NOTE:
1. CONTRACTOR TO PROVIDE SHOP DRAWINGS FOR REVIEW AND APPROVAL.
 2. MANUAL SHUT OFF VALVE TO BE PROVIDED FOR GAS BARBEQUE CONNECTION.
 3. BARBEQUE GRILL TO BE INSTALLED AS PER MANUFACTURES INSTRUCTION.
 4. REFER TO MECHANICAL DRAWINGS FOR SINK AND PLUMBING

ELEVATION

2 BBQ AND SINK WITH COUNTER NORTH
Scale: 1:25

13	RE-ISSUED FOR REZONING	22-07-19
12	RE-ISSUED FOR REZONING	22-02-23
11	RE-ISSUED FOR REZONING	22-01-19
10	ISSUED FOR VCH REVIEW	21-12-22
9	ISSUED FOR VCH REVIEW	21-09-08
8	ISSUED FOR ADP	21-07-14
7	ISSUED FOR VCH REVIEW	21-05-26
6	ISSUED FOR VCH REVIEW	21-03-26
5	ISSUED FOR REZONING	20-10-14
4	ISSUED FOR VCH REVIEW	20-10-07
3	ISSUED FOR REVIEW	20-09-18
2	ISSUED FOR REVIEW	20-07-10
1	ISSUED FOR REVIEW	20-06-29

REVISIONS

1550-EASTERN AVENUE

1550- Eastern Ave
North Vancouver, BC

Scale:	AS SHOWN
Drawn:	MR
Reviewed:	DS
Project No.	06-705

LANDSCAPE DETAILS

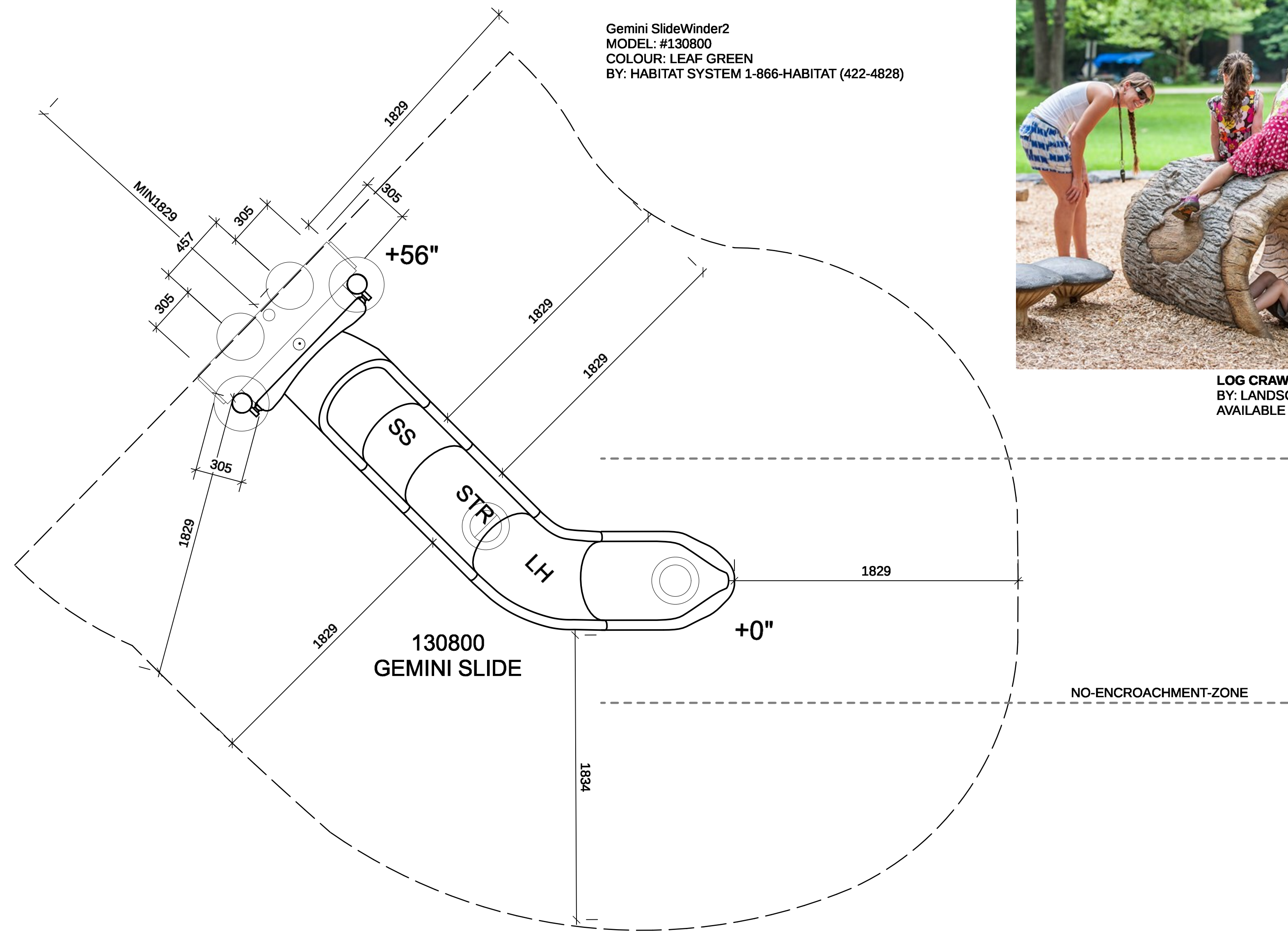

LOG CRAWL TUNNEL
BY: LANDSCAPE STRUCTURES
AVAILABLE THROUGH HABITAT

Gemini SlideWinder2
MODEL: #130800
COLOUR: LEAF GREEN
BY: HABITAT SYSTEM 1-866-HABITAT (422-4828)

1 Hill Slide
Scale: 1:20

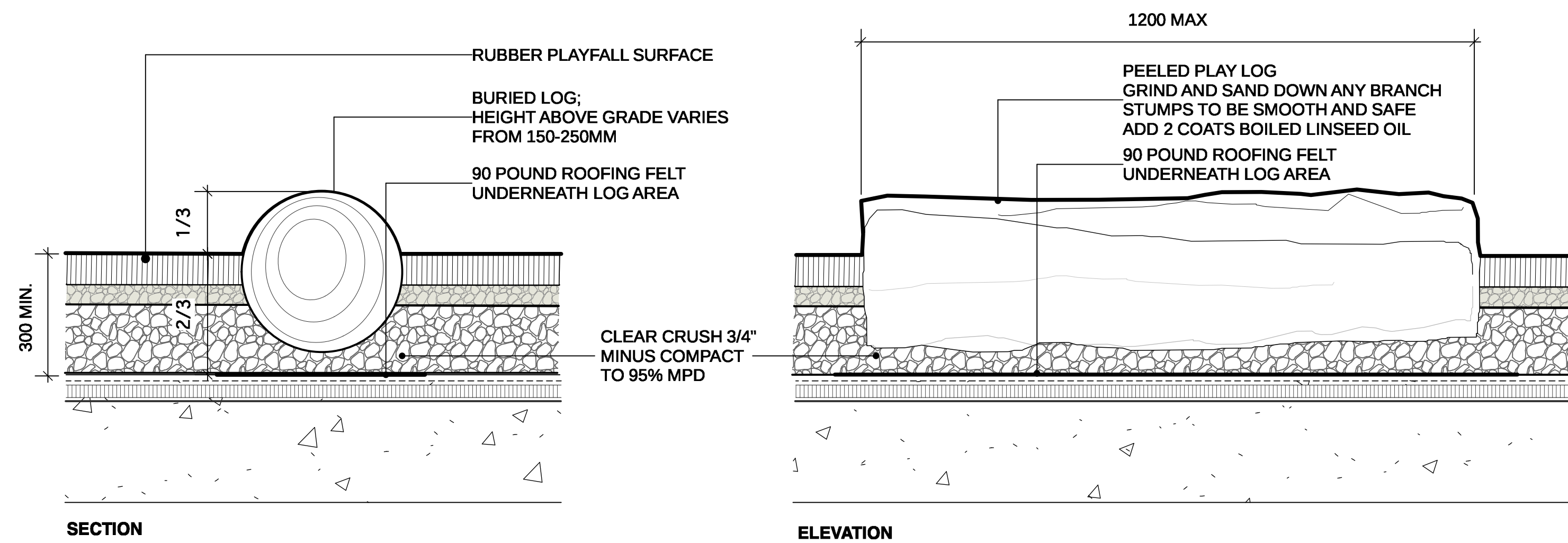

2 PLAY LOGS
Scale: 1:10

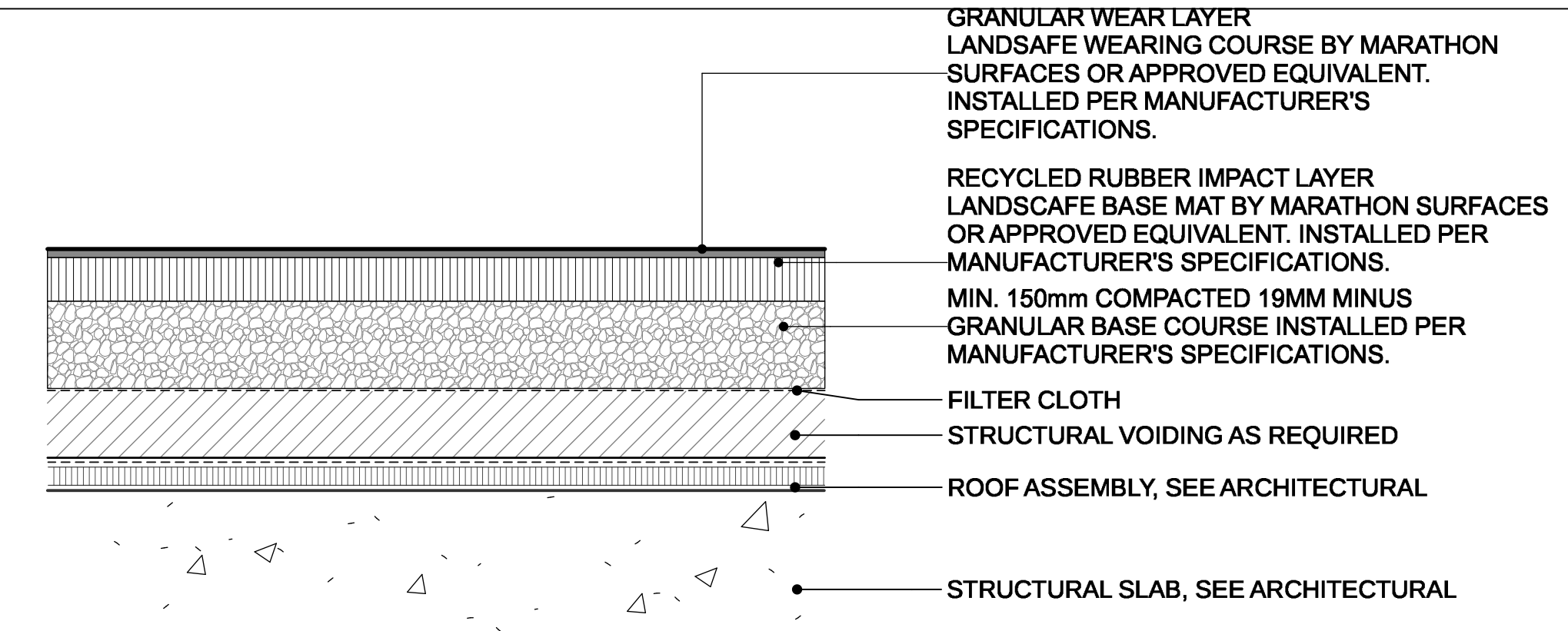

NOTES:
1. FALL SURFACING TO CONFORM TO REQUIRED CSA SAFETY STANDARDS.
2. THICKNESS OF SURFACING LAYERS TO BE DETERMINED BY CRITICAL FALL HEIGHT.

7 POURED IN PLACE RUBBER PLAYFALL SURFACE
Scale: 1:10

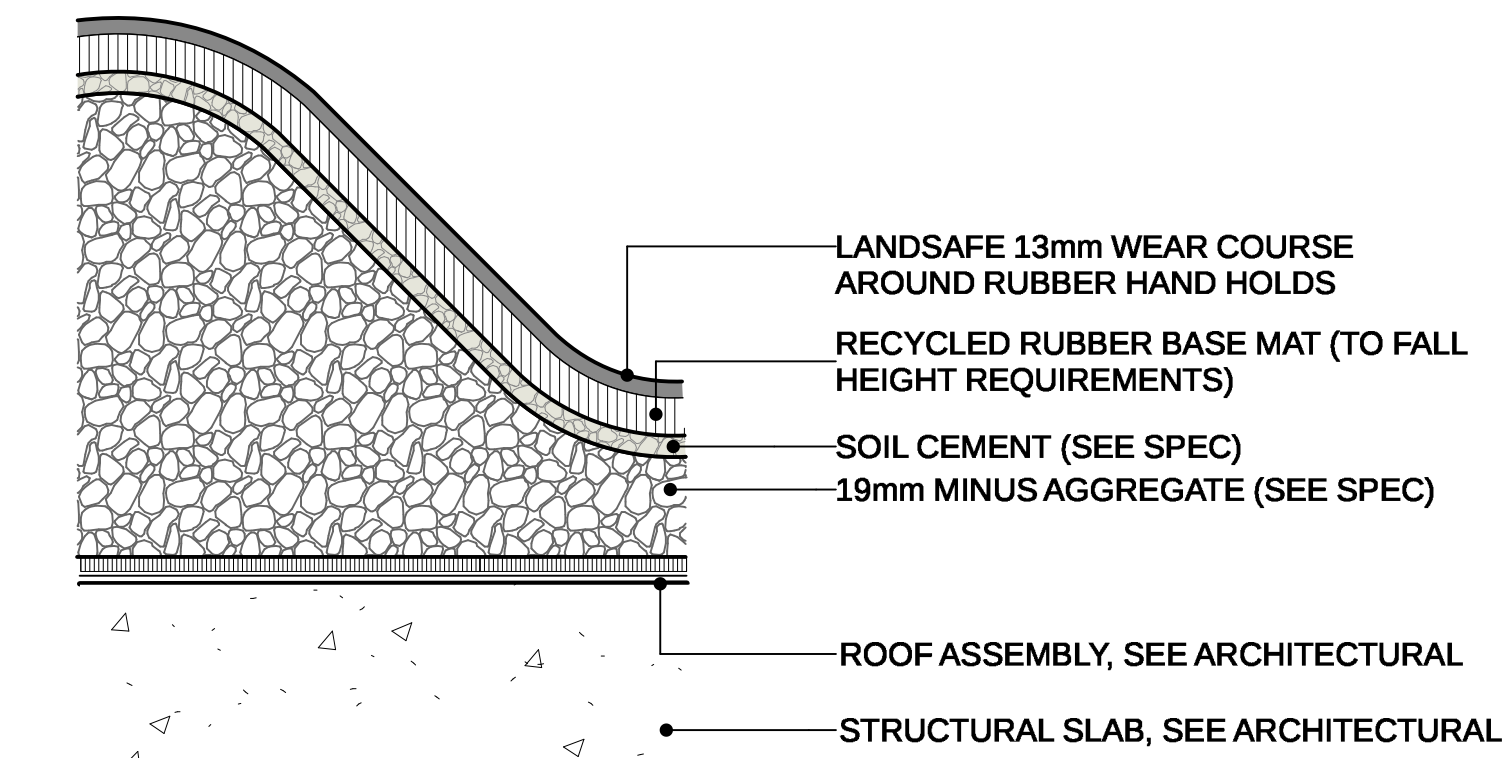

NOTES:
1. FALL SURFACING TO CONFORM TO REQUIRED CSA SAFETY STANDARDS.
2. THICKNESS OF SURFACING LAYERS TO BE DETERMINED BY CRITICAL FALL HEIGHT.

4 RUBBER PLAY MOUND ON SLAB
Scale: 1:10

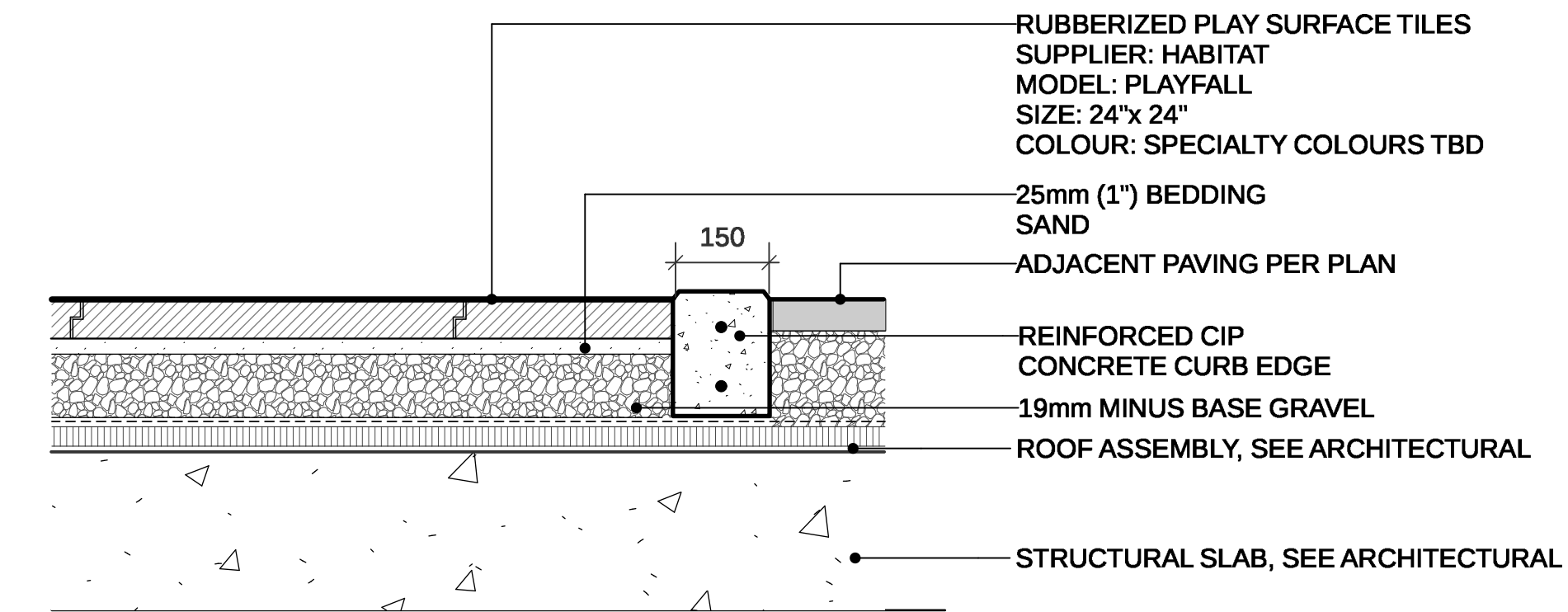

NOTE:
RUBBERIZED SURFACE TO BE PLAYFALL RUBBER PLAY SURFACE TILES, THICKNESS TO BE CONFIRMED WITH DISTRIBUTOR, OR PRE-APPROVED EQUAL.

5 RUBBERIZED PLAY TILES ON SLAB
Scale: 1:10

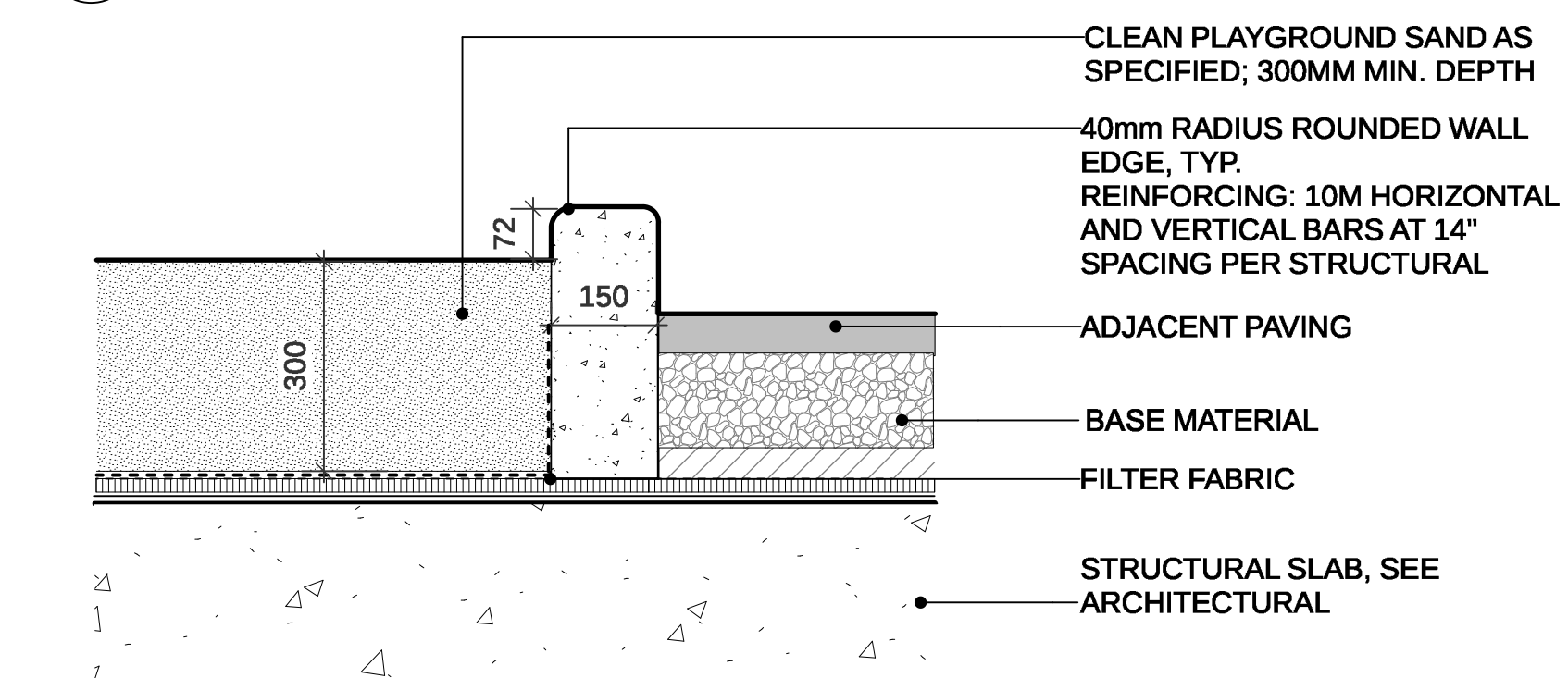

6 SAND AREA AND CURB ON SLAB
Scale: 1:10

13	RE-ISSUED FOR REZONING	22-07-19
12	RE-ISSUED FOR REZONING	22-02-23
11	RE-ISSUED FOR REZONING	22-01-19
10	ISSUED FOR VCH REVIEW	21-12-22
9	ISSUED FOR VCH REVIEW	21-09-08
8	ISSUED FOR ADP	21-07-14
7	ISSUED FOR VCH REVIEW	21-05-26
6	ISSUED FOR VCH REVIEW	21-03-26
5	ISSUED FOR REZONING	20-10-14
4	ISSUED FOR VCH REVIEW	20-10-07
3	ISSUED FOR REVIEW	20-09-18
2	ISSUED FOR REVIEW	20-07-10
1	ISSUED FOR REVIEW	20-06-29

REVISIONS

1550-EASTERN AVENUE

1550- Eastern Ave
North Vancouver, BC

Scale: AS SHOWN
Drawn: MR
Reviewed: DS
Project No. 06-705

LANDSCAPE DETAILS

CONNECT LANDSCAPE ARCHITECTURE INC.
DOES NOT GUARANTEE THE EXISTENCE,
LOCATION, AND ELEVATION OF UTILITIES AND /
OR CONCEALED STRUCTURES AT THE PROJECT
SITE.

THE CONTRACTOR IS RESPONSIBLE FOR
DETERMINING THE EXISTENCE, LOCATION, AND
ELEVATION OF ALL UTILITIES AND / OR
CONCEALED STRUCTURES, AND IS
RESPONSIBLE FOR NOTIFYING THE
APPROPRIATE COMPANY, DEPARTMENT OR
PERSON(S) OF ITS INTENTION TO CARRY OUT ITS
OPERATIONS.



ALPINE PLAY HUT
Intended user age: 2-5

PRODUCT INFORMATION

ASTM F1487

The tall peaked roof of the Alpine Hut is a clean and modern design that could fit into a range of playground themes and styles. A-Frame in style, the small house is finished with a chimney. It is fully enclosed on one side but open at the bottom on two sides providing visibility for caregivers but giving children a sense of privacy.



NON CLIMBABLE PLAY HUT

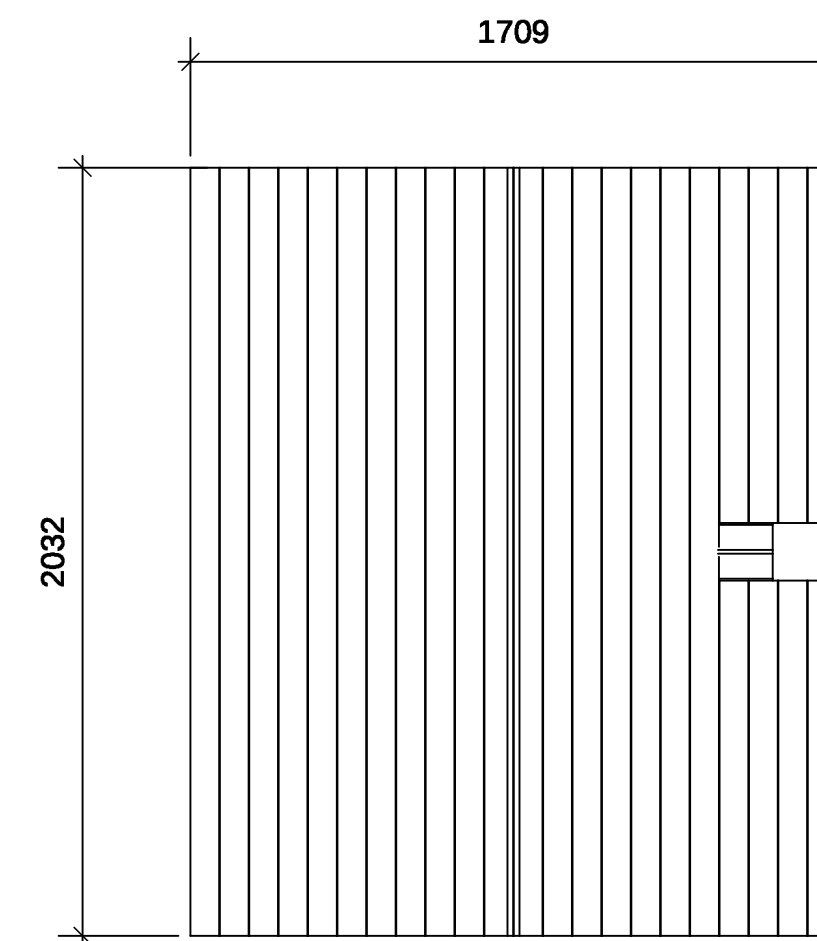
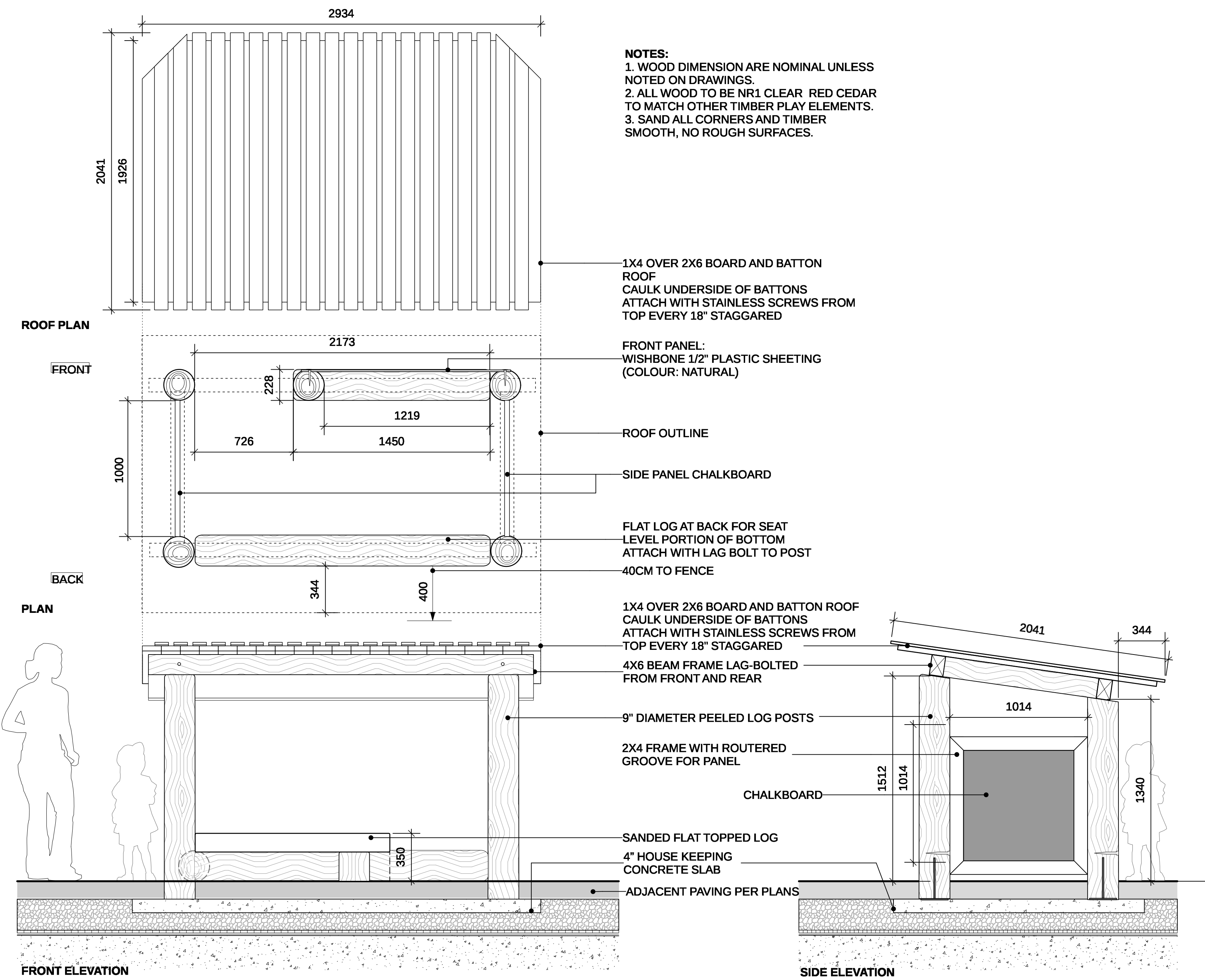

1 PLAY HOUSE LEVEL 1 ON SLAB
SCALE: 1:20

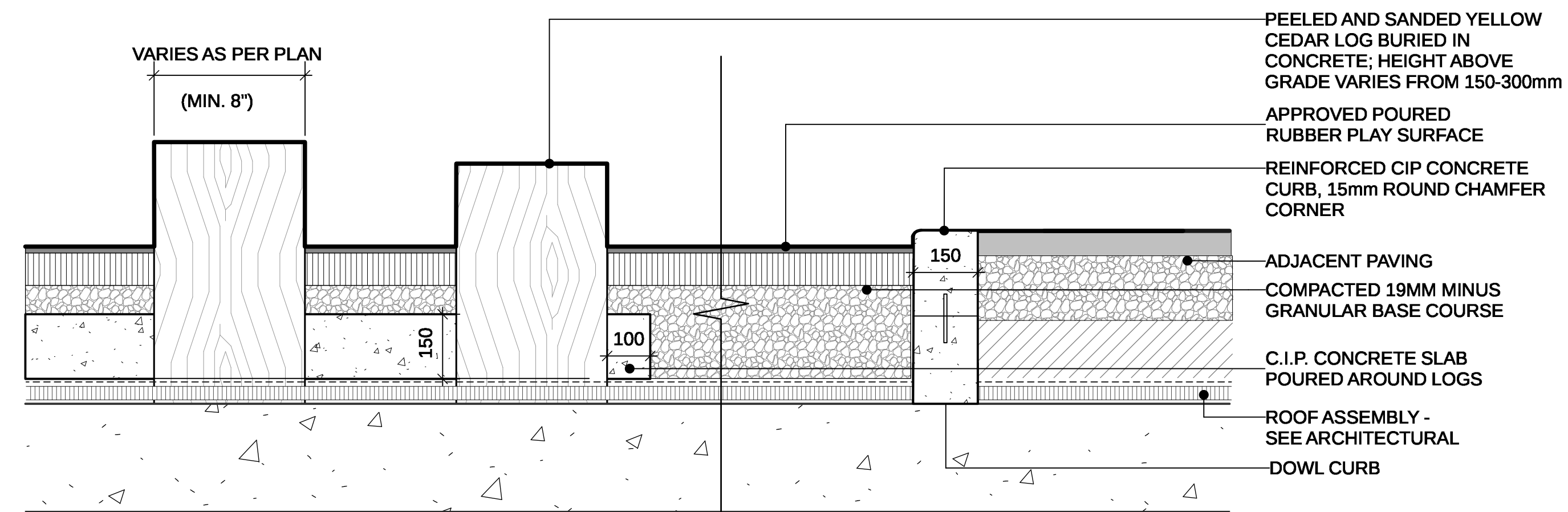

NOTES:
1. Poured RUBBER SURFACE TO BE CERTIFIED FALL SURFACE MATERIAL. SOURCE TO PROVIDE SPECIFICATIONS AND SAMPLES FOR REVIEW AND APPROVAL.
2. LOGS TO BE YELLOW CEDAR, PEELED AND SANDED. ROUNDED CORNERS NO SHARP EDGES.

3 PLAY STUMPS
Scale: 1:10

2 PLAY HOUSE LEVEL 2
SCALE: 1:20

13	RE-ISSUED FOR REZONING	22-07-19
12	RE-ISSUED FOR REZONING	22-02-23
11	RE-ISSUED FOR REZONING	22-01-19
10	ISSUED FOR VCH REVIEW	21-12-22
9	ISSUED FOR VCH REVIEW	21-09-08
8	ISSUED FOR ADP	21-07-14
7	ISSUED FOR VCH REVIEW	21-05-26
6	ISSUED FOR VCH REVIEW	21-03-26
5	ISSUED FOR REZONING	20-10-14
4	ISSUED FOR VCH REVIEW	20-10-07
3	ISSUED FOR REVIEW	20-09-18
2	ISSUED FOR REVIEW	20-07-10
1	ISSUED FOR REVIEW	20-06-29

REVISIONS

1550-EASTERN AVENUE

1550- Eastern Ave
North Vancouver, BC

Scale: AS SHOWN

Drawn: MR

Reviewed: DS

Project No. 06-705

LANDSCAPE DETAILS