

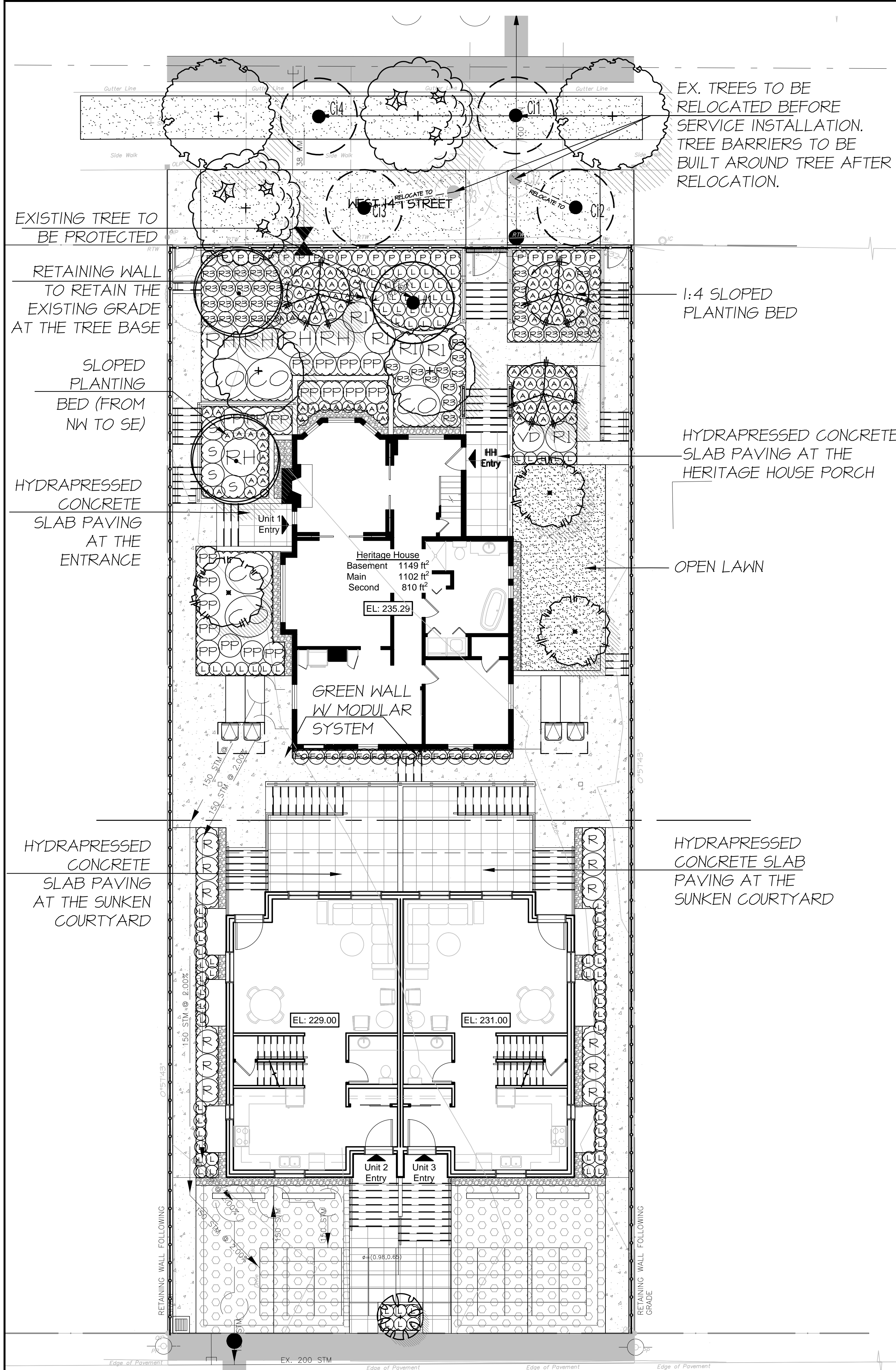

LANDSCAPE ARCHITECTURE

#220 - 26 Lorne Mews
New Westminster, British Columbia
V3M 3L7
Tel: 604.553.0044
Fax: 604.553.0045
Email: office@m2la.com

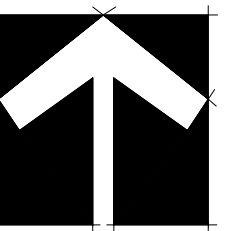

EX. TREES TO BE RELOCATED BEFORE SERVICE INSTALLATION. TREE BARRIERS TO BE BUILT AROUND TREE AFTER RELOCATION.

1:4 SLOPED PLANTING BED

HYDRAPRESSED CONCRETE SLAB PAVING AT THE HERITAGE HOUSE PORCH

OPEN LAWN

HYDRAPRESSED CONCRETE SLAB PAVING AT THE SUNKEN COURTYARD

LEGEND

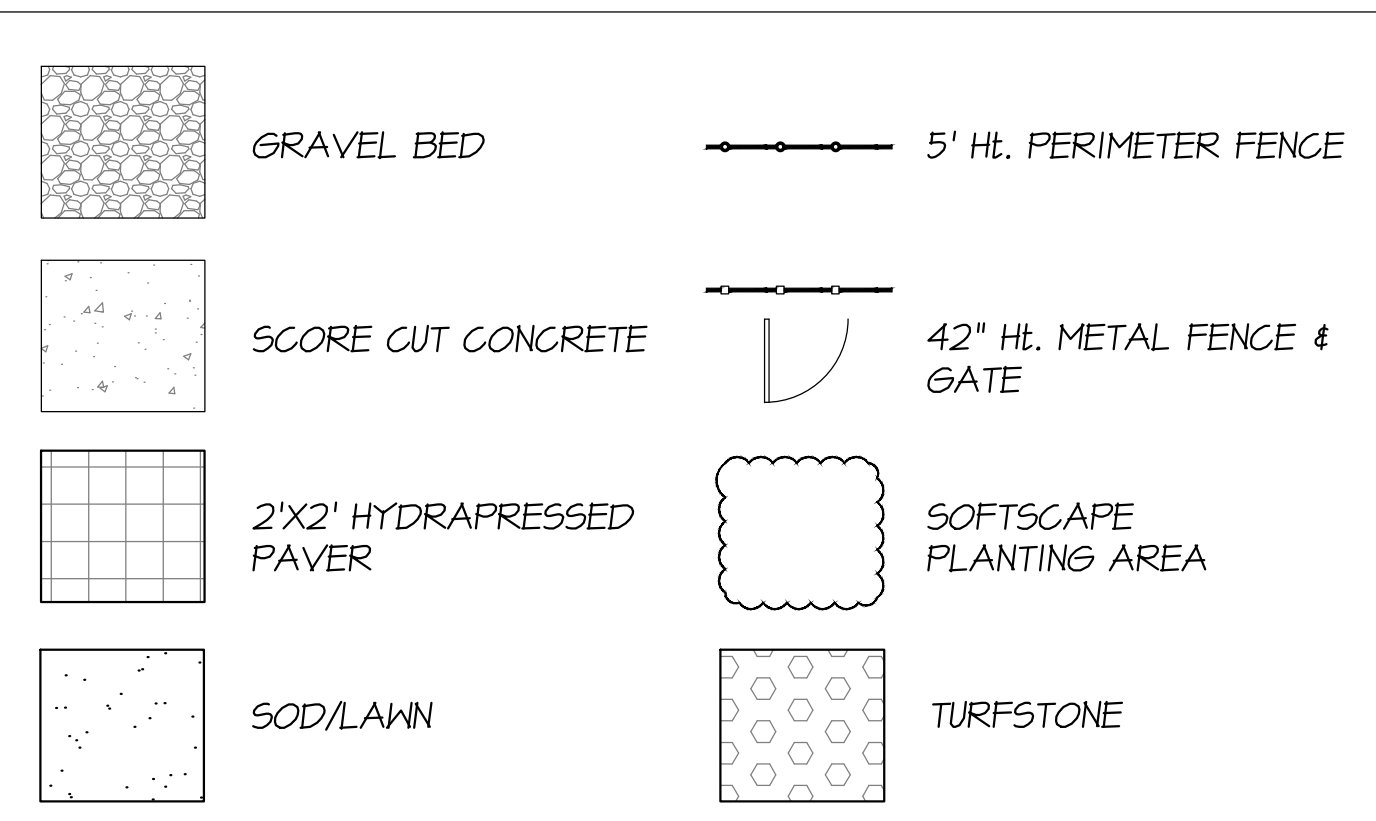

PLANT SCHEDULE - ONSITE

M2 JOB NUMBER: 22-030

KEY	QTY	BOTANICAL NAME	COMMON NAME	PLANTED SIZE / REMARKS
TREE				
	2	ACER RUBRUM 'ARMSTRONGII'	COLUMNAR RED MAPLE	6CM CAL; B&B
	2	ACER RUBRUM 'BOWHALL'	COLUMNAR BOWHALL MAPLE	6CM CAL; B&B
	3	CHAMAECYPARIS OBTUSA 'GRACILIS'	SLENDER HINOKI CYPRESS	3M HT; B&B
	1	CORNUS FLORIDA 'CHEROKEE DAYBREAK'	CHEROKEE DAYBREAK FLOWERING DOGWOOD	5CM CAL;
	3	LIQUIDAMBAR STYRACIFLUA 'SLENDER SILHOUETTE'	SLENDER SILHOUETTE SWEET GUM	6CM CAL; B&B
	1	EXISTING TREE #1 TO BE PROTECTED		
SHRUB				
	5	CORNUS SERICEA	RED OSIER DOGWOOD	#2 POT; 50CM
	12	GAULTHERIA SHALLON	SALAL	#2 POT; 30CM
	19	PHYSOCARPUS OPULIFOLIUS CAPITATUS	PACIFIC NINEBARK	#2 POT
	5	RHODODENDRON YAK 'MIST MAIDEN'	RHODODENDRON 'MIST MAIDEN'	#2 POT; 30CM
	5	ROSA RUGOSA	RUGOSA ROSE	#2 POT
	4	SPIRAEA DOUGLASII	HARDHACK	#2 POT
	1	VIBURNUM DAVIDII	DAVID'S VIBURNUM	#2 POT; 30CM
GRASS				
	23	PENNISETUM ALOPEGURIODES	FOUNTAIN GRASS	#1 POT
VINE				
	16	CLEMATIS ALPINA 'RUBY'	CLEMATIS 'RUBY'	#1 POT; 50CM STAKED
PERENNIAL				
	87	LAVENDULA ANGUSTIFOLIA	ENGLISH LAVENDER	#1 POT
	41	RUDBECKIA FULGIDA VAR SULLIVANTII 'GOLDSTURM'	RUDBECKIA	#1 POT
GC				
	112	ADIANTUM PEDATUM	MAIDENHAIR FERN	#2 POT; 35CM

NOTES: * PLANT SIZES IN THIS LIST ARE SPECIFIED ACCORDING TO THE BC LANDSCAPE STANDARD, LATEST EDITION. CONTAINER SIZES SPECIFIED AS PER CNTA STANDARDS. BOTH PLANT SIZE AND CONTAINER SIZE ARE THE MINIMUM ACCEPTABLE SIZES. * REFER TO SPECIFICATIONS FOR DEFINED CONTAINER MEASUREMENTS AND OTHER PLANT MATERIAL REQUIREMENTS. * SEARCH AND REVIEW: MAKE PLANT MATERIAL AVAILABLE FOR OPTIONAL REVIEW BY LANDSCAPE ARCHITECT AT SOURCE OF SUPPLY. AREA OF SEARCH TO INCLUDE LOWER MAINLAND AND FRASER VALLEY. * SUBSTITUTIONS: OBTAIN WRITTEN APPROVAL FROM THE LANDSCAPE ARCHITECT PRIOR TO MAKING ANY SUBSTITUTIONS TO THE SPECIFIED MATERIAL. UNAPPROVED SUBSTITUTIONS WILL BE REJECTED. ALLOW A MINIMUM OF FIVE DAYS PRIOR TO DELIVERY FOR REQUEST TO SUBSTITUTE. SUBSTITUTIONS ARE SUBJECT TO BC LANDSCAPE STANDARD - DEFINITION OF CONDITIONS OF AVAILABILITY.

ALL PLANT MATERIAL MUST BE PROVIDED FROM CERTIFIED DISEASE FREE NURSERY. PROVIDE CERTIFICATION UPON REQUEST.

NO.	DATE	REVISION DESCRIPTION	DR.
8	2023-09-21	ISSUED FOR BP	GL
7	2023-09-09	ISSUED FOR DP	GL
6	2023-02-15	ISSUED FOR DP	GL
5	2023-08-16	ISSUED FOR DP	GL
4	2023-08-16	ISSUED FOR DP	GL
3	2023-08-05	ISSUED FOR DP	GL
2	2023-07-24	ISSUED FOR PRELIMINARY DESIGN	GL
1	2022-07-28	ISSUED FOR PRELIMINARY DESIGN	GL

SEAL:

PROJECT:

HERITAGE REVITALIZATION AND
NEW LOW ENERGY DUPLEX
311 W 14TH STREET
CITY OF NORTH VANCOUVER, BC

DRAWING TITLE:

LANDSCAPE
LAYOUT PLAN

DATE: JUL 1, 2022

SCALE: 1"=1/8"

DRAWN: GL

DESIGN: GL

CHK'D: MTLM

DRAWING NUMBER:

L1

OF 10

M2LA PROJECT NUMBER:

22-030



LANDSCAPE ARCHITECTURE

#220 - 26 Lorne Mews
 New Westminster, British Columbia
 V3M 3L7
 Tel: 604.553.0044
 Fax: 604.553.0045
 Email: office@m2la.com

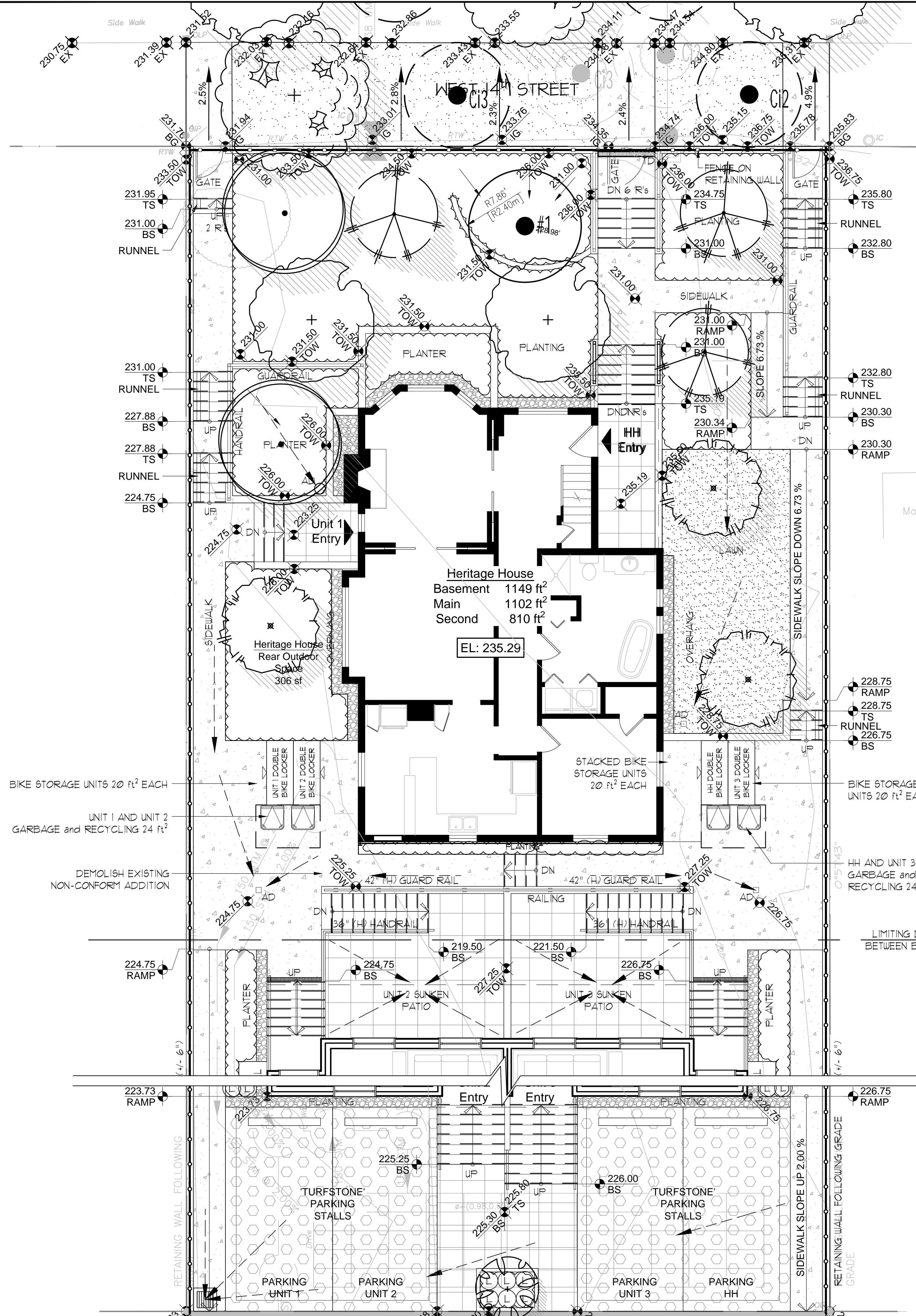
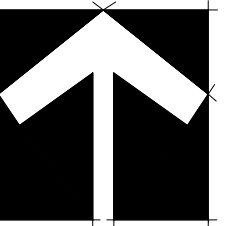

GRADING LEGEND

- XXX.XX TS TOP OF STEP
- XXX.XX BS BOTTOM OF STEP
- XXX.XX TW TOP OF WALL
- XXX.XX RAMP TOP/BOTTOM OF RAMP
- XXX.XX PROPOSED FINISH GRADE
- XXX.XX IG CIVIL GRADE

DRAINAGE LEGEND

- AD AREA DRAIN
- > DRAINAGE DIRECTION
- ▬ DRENCH DRAIN
- ▭ CATCH BASIN

NO.	DATE	REVISION DESCRIPTION	DR.
8	2023-09-21	ISSUED FOR BP	GL
7	2023-09-09	ISSUED FOR DP	GL
6	2023-02-15	ISSUED FOR DP	GL
5	2023-08-14	ISSUED FOR DP	GL
4	2023-08-14	ISSUED FOR DP	GL
3	2023-08-02	ISSUED FOR DP	GL
2	2023-07-24	ISSUED FOR PRELIMINARY DESIGN	GL
1	2022-07-28	ISSUED FOR PRELIMINARY DESIGN	GL

SEAL:

PROJECT:
 HERITAGE REVITALIZATION AND
 NEW LOW ENERGY DUPLEX
 311 W 14TH STREET
 CITY OF NORTH VANCOUVER, BC

DRAWING TITLE:
**GRADING &
 DRAINAGE PLAN**

DATE: JUL 21, 2022	DRAWING NUMBER:
SCALE: 1"=3/16"	L2
DRAWN: GL	
DESIGN: GL	
CHK'D: MTLM	OF 10
M2LA PROJECT NUMBER:	22-030



#220 - 26 Lorne Mews
 New Westminster, British Columbia
 V3M 3L7
 Tel: 604.553.0044
 Fax: 604.553.0045
 Email: office@m2la.com

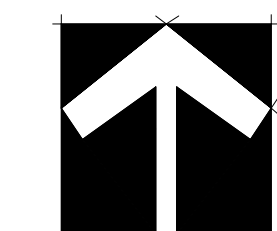

NO.	DATE	REVISION DESCRIPTION	DR.
8	2023-09-21	ISSUED FOR BP	GL
7	2023-09-09	ISSUED FOR DP	GL
6	2023-02-15	ISSUED FOR DP	GL
5	2022-08-14	ISSUED FOR DP	GL
4	2022-08-14	ISSUED FOR DP	GL
3	2022-08-02	ISSUED FOR DP	GL
2	2022-07-24	ISSUED FOR PRELIMINARY DESIGN	GL
1	2022-07-21	ISSUED FOR PRELIMINARY DESIGN	GL

SEAL:

PROJECT:
**HERITAGE REVITALIZATION AND
 NEW LOW ENERGY DUPLEX**
 311 W 14TH STREET
 CITY OF NORTH VANCOUVER, BC

DRAWING TITLE:
**IRRIGATION
 PLAN**

DATE: JUL 21/22	DRAWING NUMBER:
SCALE: 1"=3/16"	L3
DRAWN: GL	
DESIGN: GL	
CHK'D: MTLM	OF 10
M2LA PROJECT NUMBER:	22-030

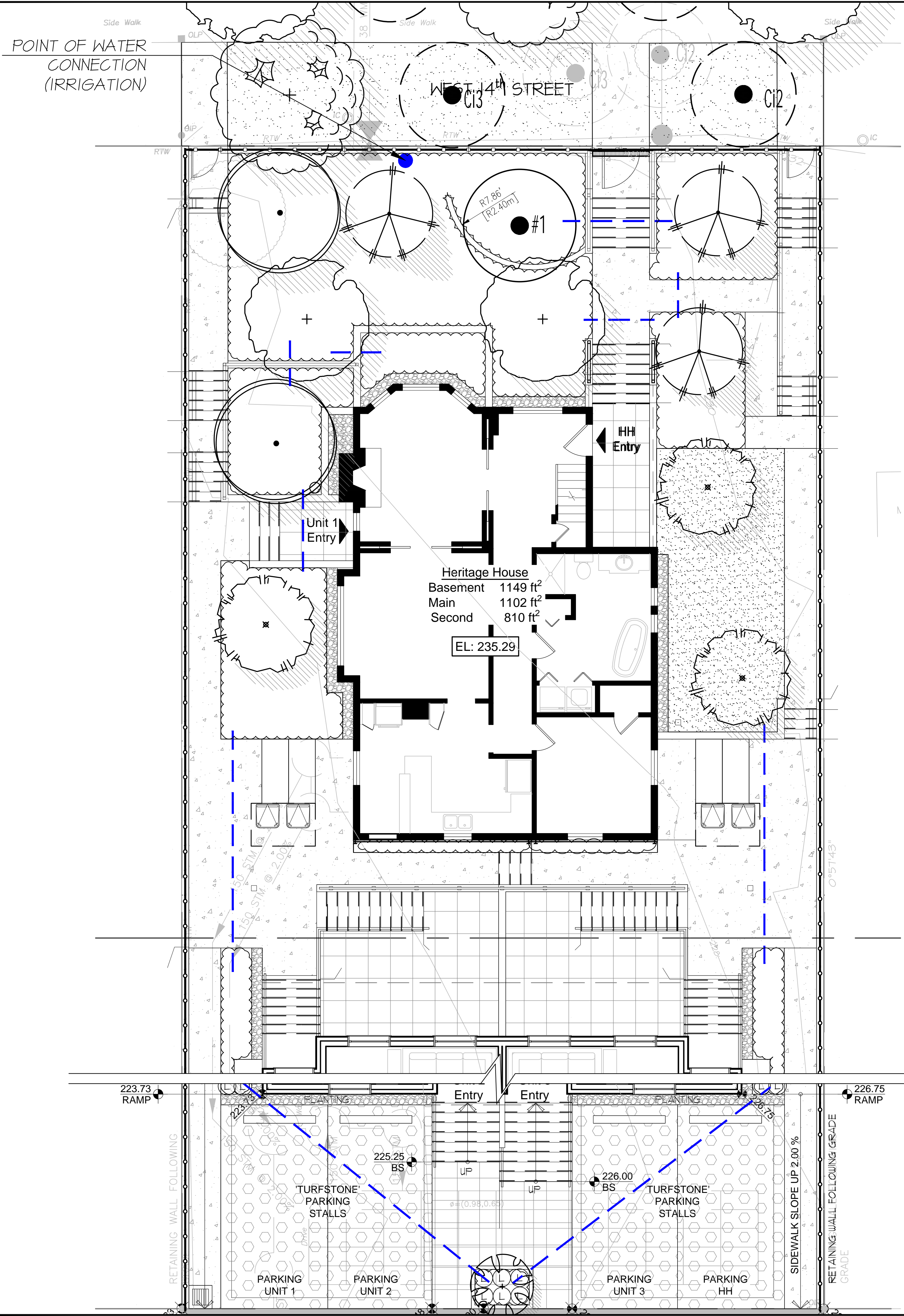

LEGEND

--- IRRIGATION SLEEVE

● POINT OF WATER CONNECTION



#220 - 26 Lorne Mews
 New Westminster, British Columbia
 V3M 3L7
 Tel: 604.553.0044
 Fax: 604.553.0045
 Email: office@m2la.com

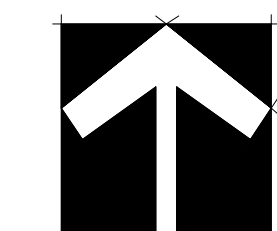

NO.	DATE	REVISION DESCRIPTION	DR.
8	2023-09-21	ISSUED FOR BP	GL
7	2023-09-09	ISSUED FOR DP	GL
6	2023-02-05	ISSUED FOR DP	GL
5	2022-08-16	ISSUED FOR DP	GL
4	2022-08-16	ISSUED FOR DP	GL
3	2022-08-01	ISSUED FOR DP	GL
2	2022-07-24	ISSUED FOR PRELIMINARY DESIGN	GL
1	2022-07-28	ISSUED FOR PRELIMINARY DESIGN	GL

SEAL:

PROJECT:
**HERITAGE REVITALIZATION AND
 NEW LOW ENERGY DUPLEX**
 311 W 14TH STREET
 CITY OF NORTH VANCOUVER, BC

DRAWING TITLE:
**LIGHTING
 PLAN**

DATE: JUL 1, 2022	DRAWING NUMBER:
SCALE: 1"=1/8"	L4
DRAWN: GL	
DESIGN: GL	
CHK'D: MTLM	OF 10

WAC LIGHTING

WL-LED140 Step And Wall Light

Model & Voltage	Color Temp & CRI	Lumens	Finish
○ WL-LED140 120 VAC	○ Amber 90	3	○ BK Black on Aluminum
○ WL-LED140F 277 VAC	○ White 90	3	○ BZ Bronze on Aluminum
	○ Amber 90	3	○ WT White on Aluminum
	○ White 90	3	

Example: **WL-LED140-AM-BK**

DESCRIPTION

WAC Lighting Step and Wall Lights are designed to seamlessly blend into any architecture featuring a sleek interchangeable magnetic faceplate with no visible hardware. These luminaires offer enhanced energy-efficient functionality and optimized light output to adequately illuminate stairs, walls and walkways with little or no glare. Light engine is IP66 sealed for both indoor and outdoor applications.

FEATURES

- Geometric design with downward illumination
- Magnetized design for easy installation and maintenance
- Low profile, flush to wall aesthetics with no visible hardware
- 5 year warranty

SPECIFICATIONS

Construction:	Die-cast corrosion resistant aluminum alloy
Power:	3W, 3.5W
Input:	277 VAC, 50/60Hz, 120 VAC
Dimming:	, ELV: 100-10%
Light Source:	Integrated LED
Rated Life:	50000 Hours
Mounting:	Fits into 2" x 4" J-Box with minimum inside dimensions of 3" x 2" W x 2.5" D
Finish:	Enamel Coated: White on Aluminum, Bronze on Aluminum, Black on Aluminum
Operating Temp:	-40°F to 104°F (-40°C to 40°C)
Standards:	ETL, cETL, Wet Location Listed, IP66, ADA, Title 24 JAB-2019 Compliant

FINISHES:



LINE DRAWING:

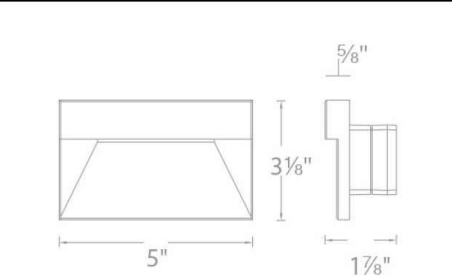

REPLACEMENT PARTS

- W-4091-140-BK - LED140 Cover Plate BK
- W-4091-140-BZ - LED140 Cover Plate BZ
- W-4091-140-WT - LED140 Cover Plate WT

wacighting.com | Phone (800) 526.2588 | Fax (800) 526.2585 | Headquarters/Eastern Distribution Center 44 Harbor Park Drive Port Washington, NY 11050
 WAC Lighting retains the right to modify the design of our products at any time as part of the company's continuous improvement program. August 2022

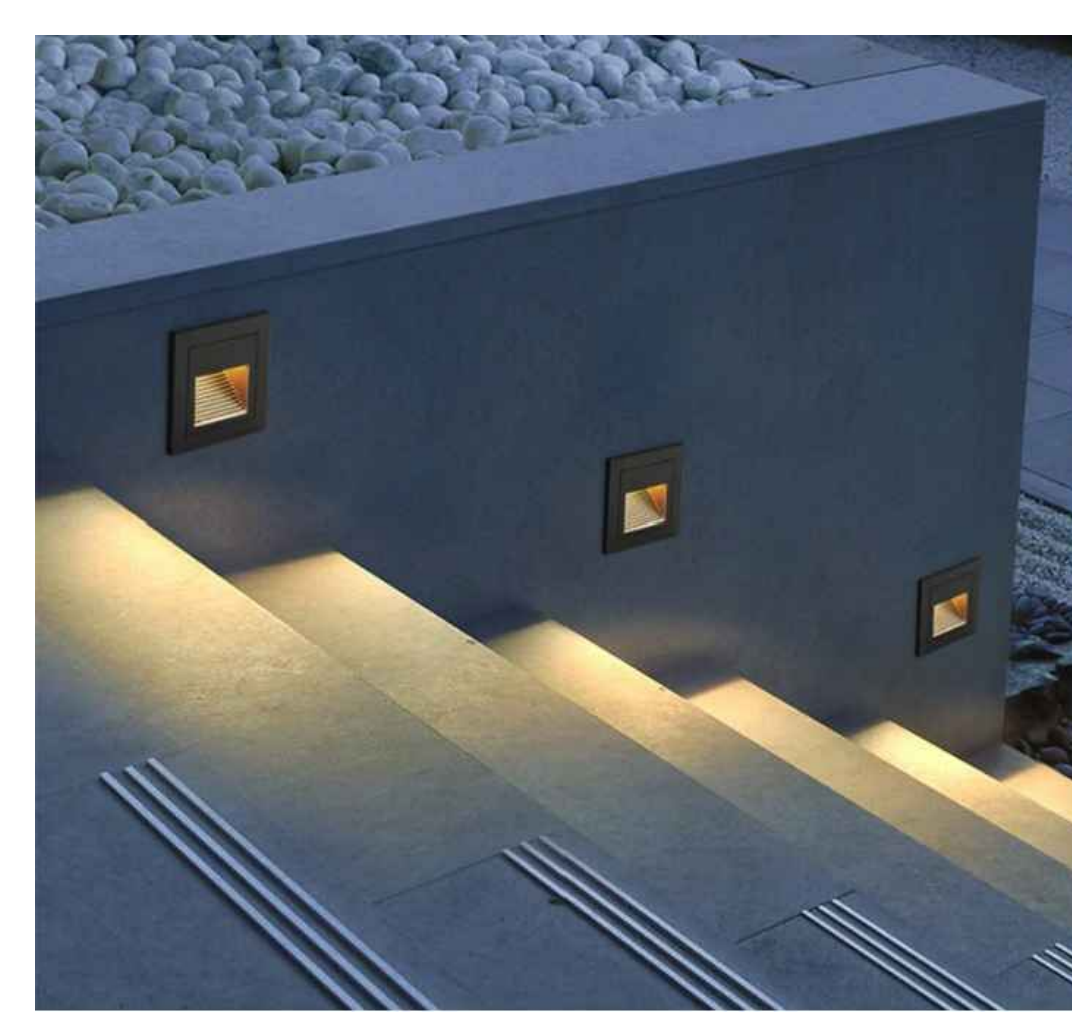

WAC LANDSCAPE LIGHTING

QUAD LED PATH LIGHT 6091



PRODUCT DESCRIPTION

Sleek linear design blends seamlessly into pathways while providing soft, even illumination

SPECIFICATIONS

Input:	9-15VAC (Transformer is required)
Power:	3.0W / 4.5VA
Brightness:	Up to 100 lm
CR:	90
Rated Life:	60,000 hours

FEATURES

- IP66 rated, Protected against powerful water jets
- Factory sealed water tight fixtures
- Solid diecast corrosion resistant aluminum alloy
- Recommended spacing for installation: Residential 8 to 10ft; Commercial: 5 to 7ft
- Mounting stake, 6 foot lead wire, and direct burial gel filled wire nuts are included
- Maintains constant lumen output against voltage drop
- UL & cUL 1838 Listed

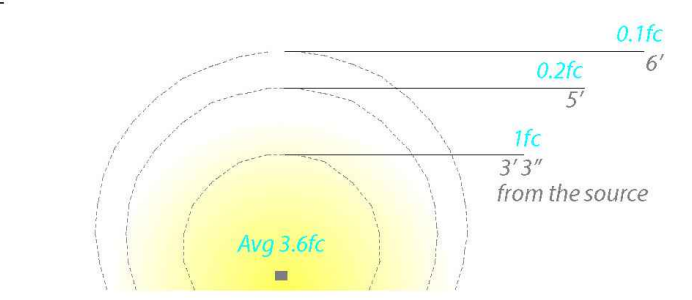

ORDERING NUMBER

		Color Temp	Finish
6091	Quad	27 2700K Warm White	BZ Bronze on Aluminum
		30 3000K Pure White	

6091 - BZ

Example: 6091-30BZ

wacighting.com Phone (800) 526.2588 Fax (800) 526.2585
 Headquarters/Eastern Distribution Center 44 Harbor Park Drive Port Washington, NY 11050
 Central Distribution Center 1600 Distribution Ct Lithia Springs, GA 30122
 Western Distribution Center 1750 Archibald Avenue Ontario, CA 91760

WAC Lighting retains the right to modify the design of our products at any time as part of the company's continuous improvement program.



LIGHTING LEGEND

- BOLLARD LIGHT
- STEP LIGHT

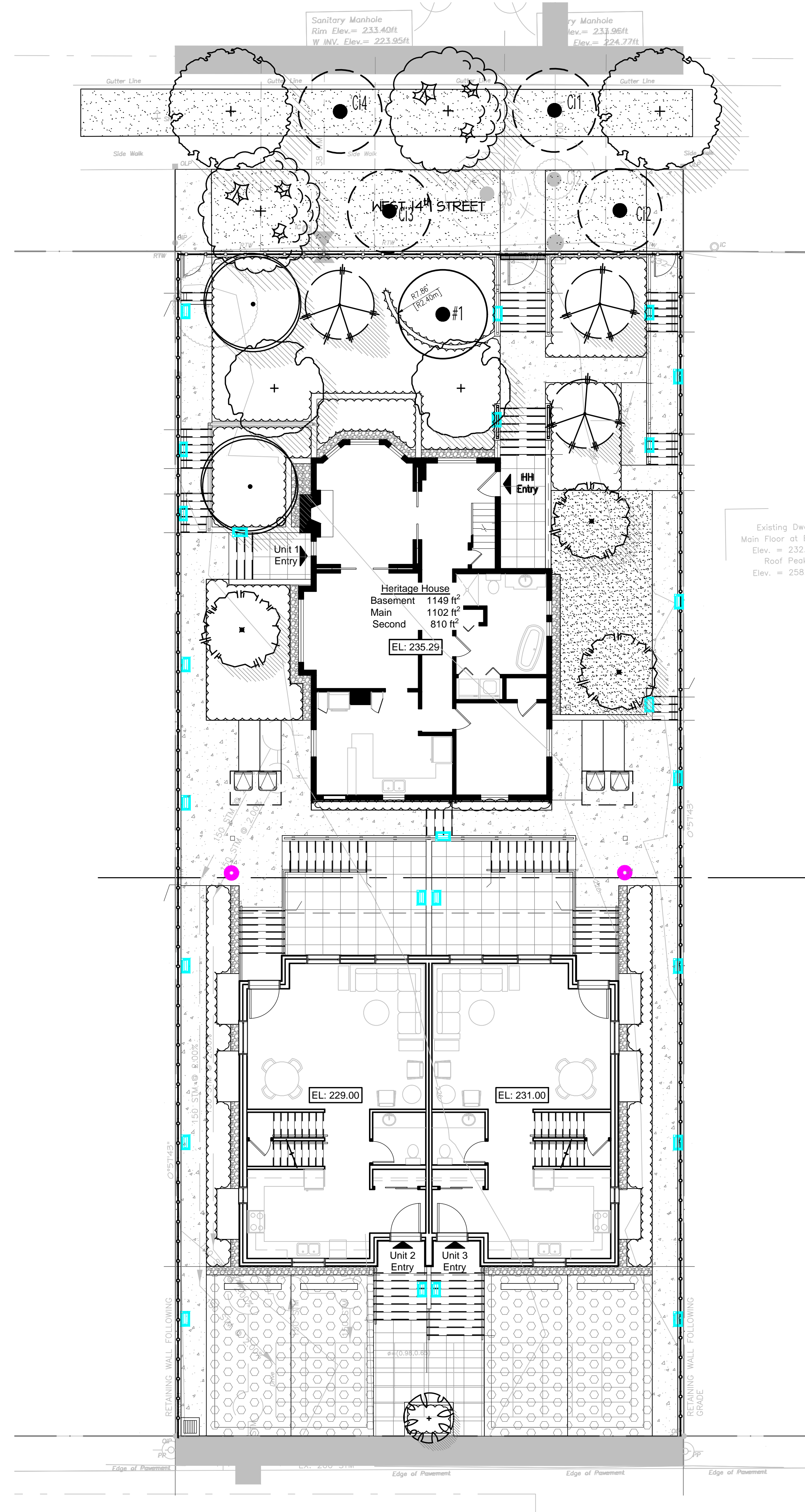

West 14th Street

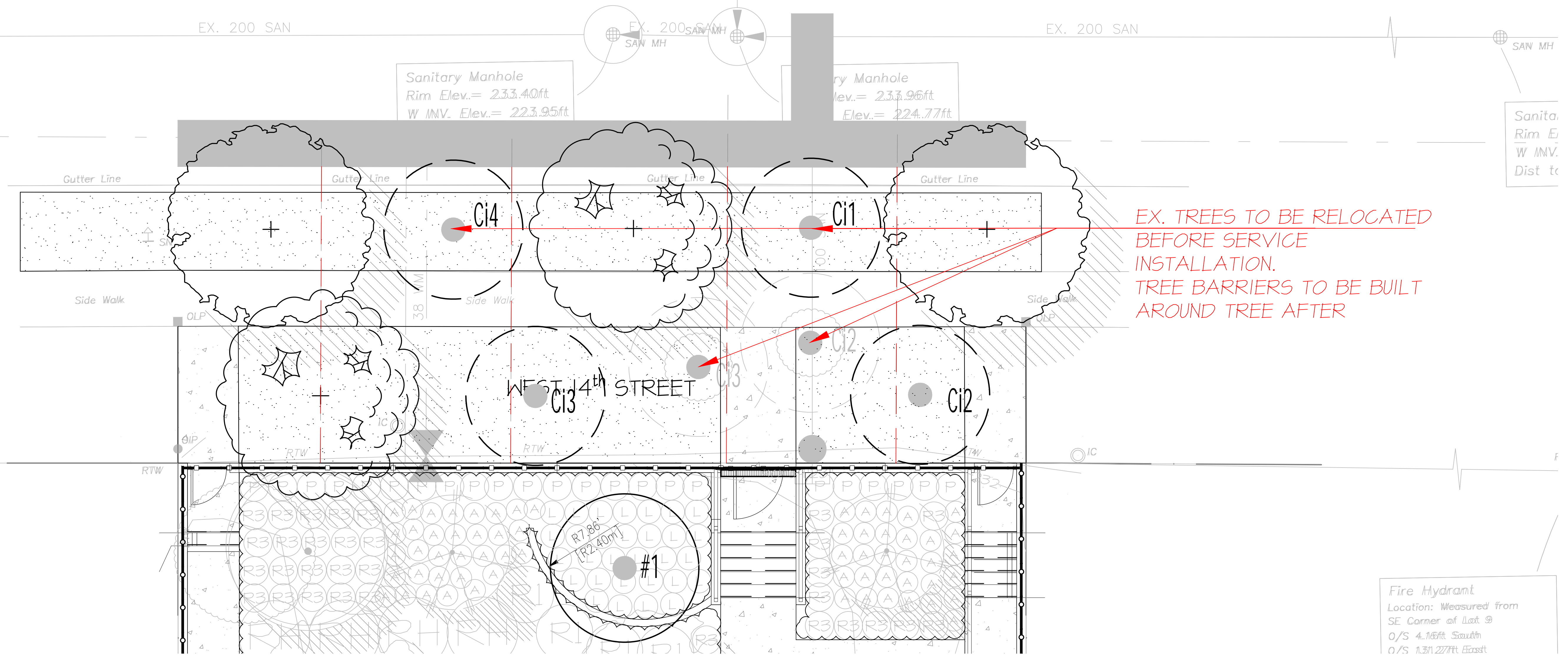

LEGEND

--- CLEARANCE FROM THE UNDERGROUND SERVICE LINES

PLANT SCHEDULE - OFFSITE				M2 JOB NUMBER: 22-030
KEY	QTY	BOTANICAL NAME	COMMON NAME	PLANTED SIZE / REMARKS
	2	ACER CIRCINATUM	VINE MAPLE	1.5M HT; B4B;
	2	QUERCUS COCCINEA	SCARLET OAK	6CM CAL; B4B
	1	EXISTING CITY TREE C11 TO BE RELOCATED		
	1	EXISTING CITY TREE C12 TO BE RELOCATED		
	1	EXISTING CITY TREE C13 TO BE RELOCATED		
	1	EXISTING CITY TREE C14 TO BE RELOCATED		

NOTES: * PLANT SIZES IN THIS LIST ARE SPECIFIED ACCORDING TO THE BC LANDSCAPE STANDARD, LATEST EDITION. CONTAINER SIZES SPECIFIED AS PER CNRA STANDARDS. BOTH PLANT SIZE AND CONTAINER SIZE ARE THE MINIMUM ACCEPTABLE SIZES. * REFER TO SPECIFICATIONS FOR DEFINED CONTAINER MEASUREMENTS AND OTHER PLANT MATERIAL REQUIREMENTS. * SEARCH AND REVIEW: MAKE PLANT MATERIAL AVAILABLE FOR OPTIONAL REVIEW BY LANDSCAPE ARCHITECT AT SOURCE OF SUPPLY. AREA OF SEARCH TO INCLUDE LOWER MAINLAND AND FRASER VALLEY. * SUBSTITUTIONS: OBTAIN WRITTEN APPROVAL FROM THE LANDSCAPE ARCHITECT PRIOR TO MAKING ANY SUBSTITUTIONS TO THE SPECIFIED MATERIAL. UNAPPROVED SUBSTITUTIONS WILL BE REJECTED. ALLOW A MINIMUM OF FIVE DAYS PRIOR TO DELIVERY FOR REQUEST TO SUBSTITUTE. SUBSTITUTIONS ARE SUBJECT TO BC LANDSCAPE STANDARD - DEFINITION OF CONDITIONS OF AVAILABILITY.

ALL PLANT MATERIAL MUST BE PROVIDED FROM CERTIFIED DISEASE FREE NURSERY. PROVIDE CERTIFICATION UPON REQUEST.

Copyright reserved. This drawing and design is the property of M2 Landscape Architects and may not be reproduced or used for other projects without their permission.



#220 - 26 Lorne Mews
New Westminster, British Columbia
V3M 3L7
Tel: 604.553.0044
Fax: 604.553.0045
Email: office@m2la.com

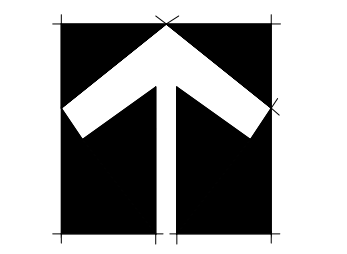

NO.	DATE	REVISION DESCRIPTION	DR.
8	2023-09-21	ISSUED FOR BP	GL
7	2023-09-09	ISSUED FOR DP	GL
6	2023-02-15	ISSUED FOR DP	GL
5	2023-08-14	ISSUED FOR DP	GL
4	2023-08-14	ISSUED FOR DP	GL
3	2023-08-02	ISSUED FOR DP	GL
2	2023-07-24	ISSUED FOR PRELIMINARY DESIGN	GL
1	2022-07-28	ISSUED FOR PRELIMINARY DESIGN	GL

SEAL:

PROJECT:
HERITAGE REVITALIZATION AND
NEW LOW ENERGY DUPLEX
311 W 14TH STREET
CITY OF NORTH VANCOUVER, BC

DRAWING TITLE:
OFFSITE LANDSCAPE PLAN

DATE: JUL 21 2022	DRAWING NUMBER:
SCALE: 1"=10'	L5
DRAWN: GL	
DESIGN: GL	
CHK'D: MTLM	
M2LA PROJECT NUMBER: 22-030-04	OF 10 22-030

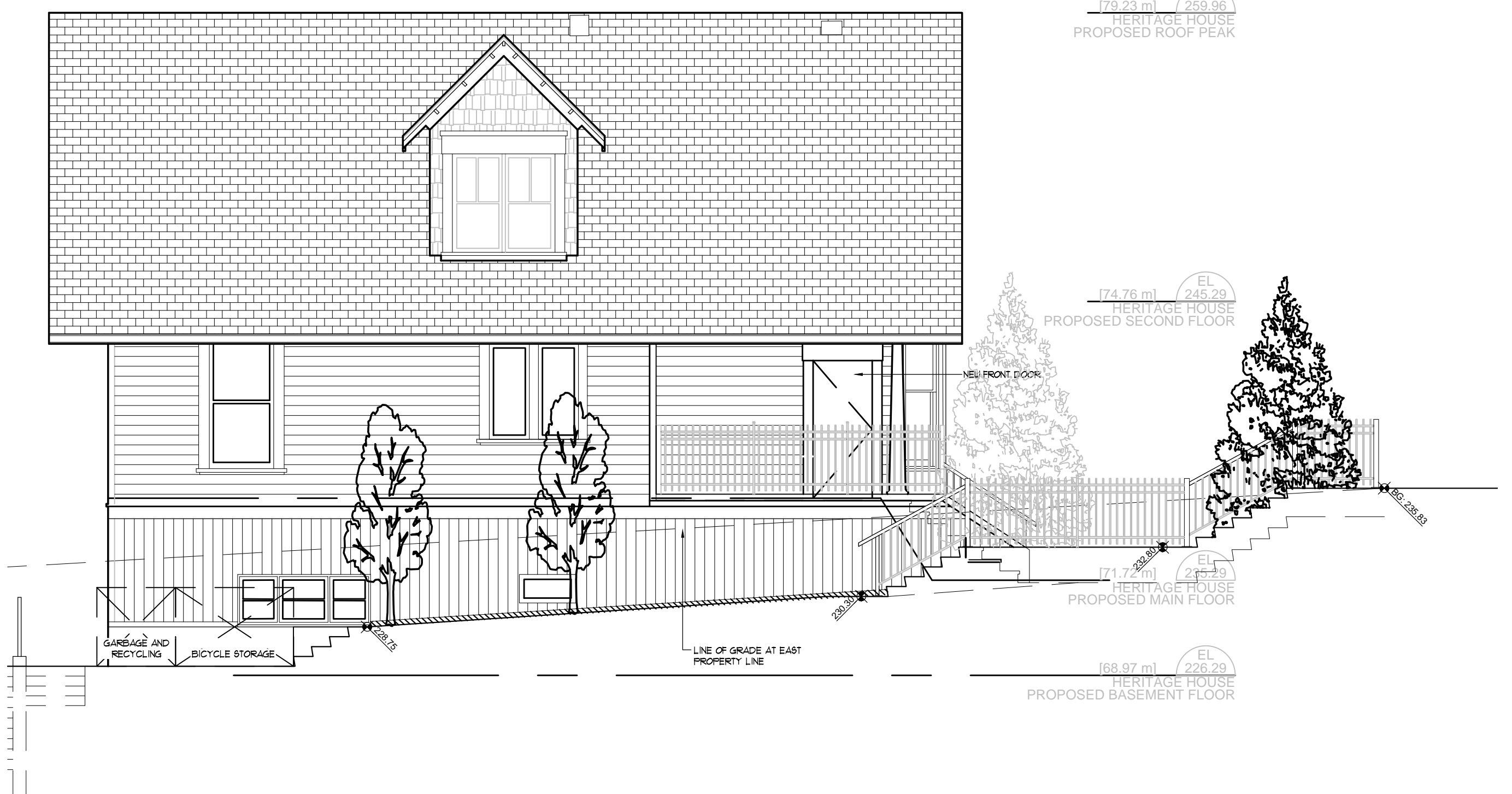
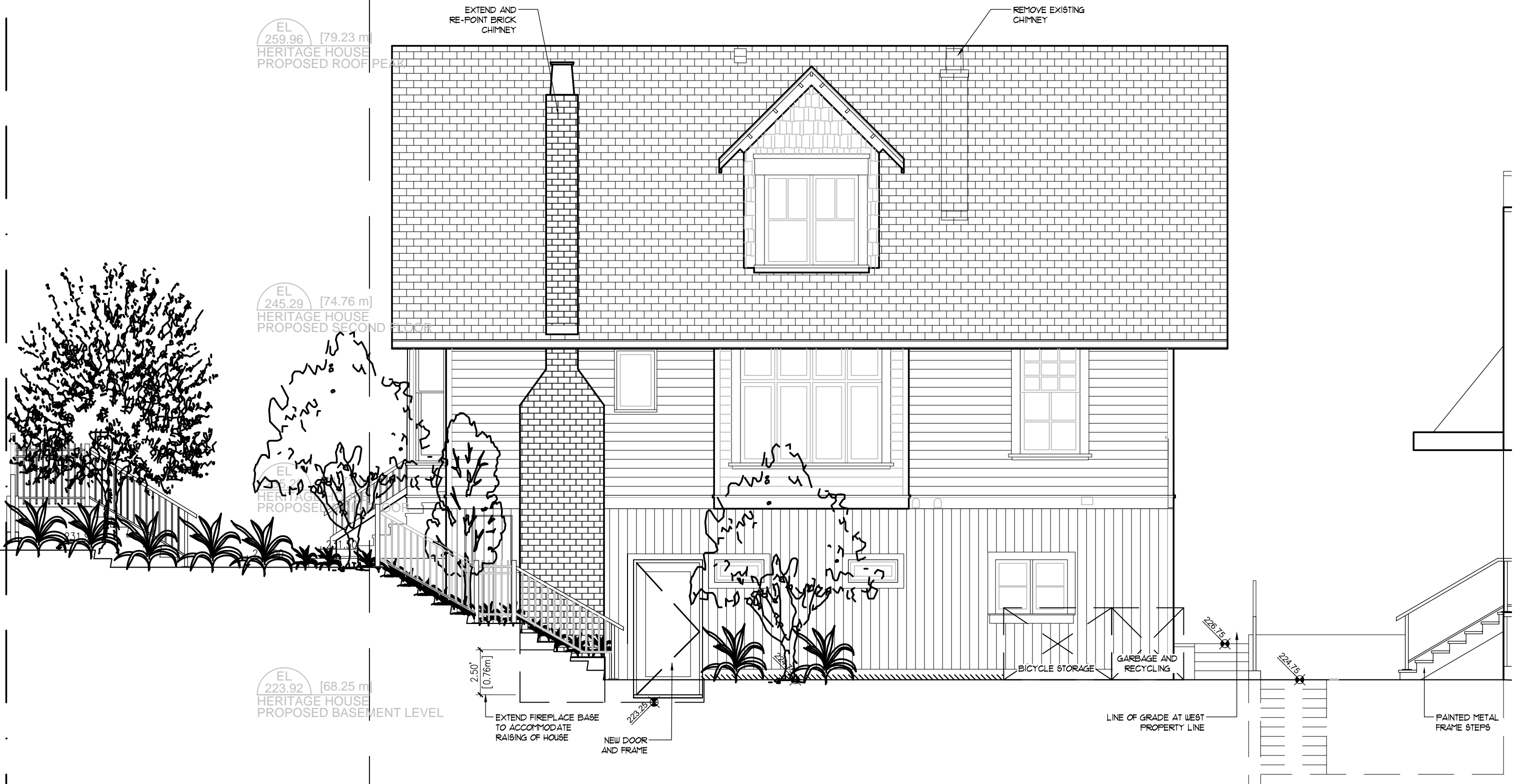
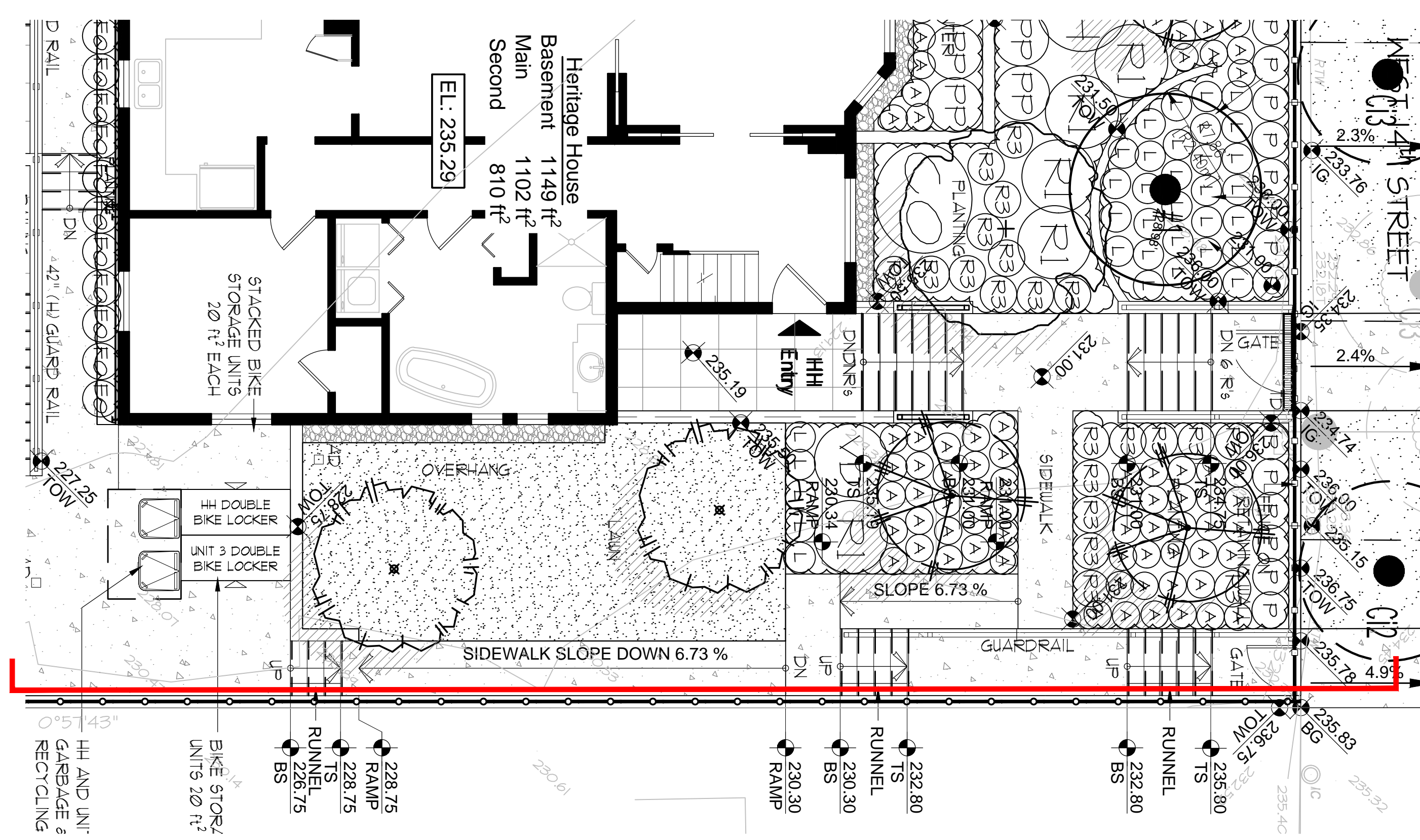
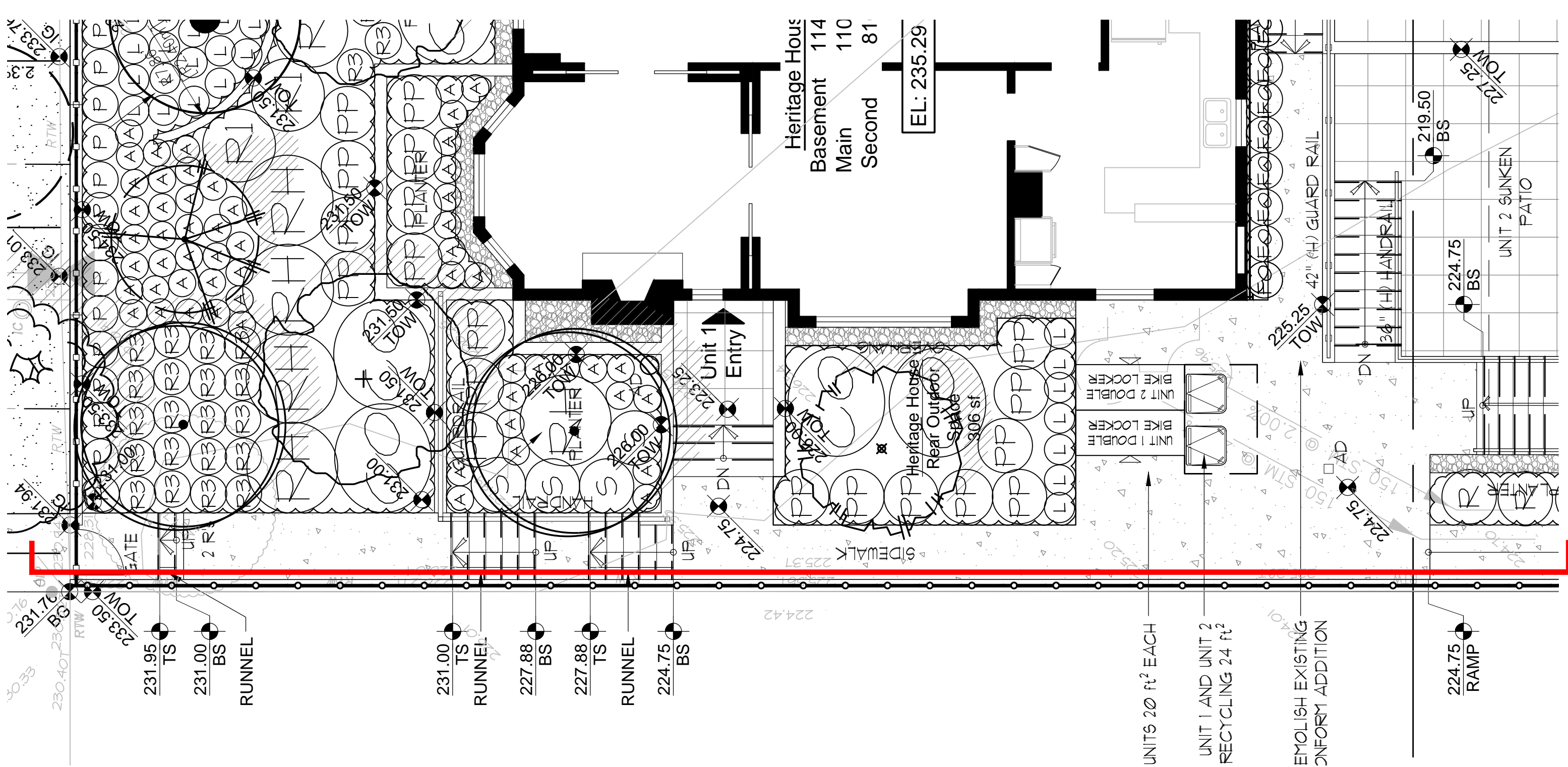

01 HERITAGE HOUSE WEST ELEVATION
L7 SCALE: 1"=3/16"

02 HERITAGE HOUSE EAST ELEVATION
L7 SCALE: 1"=3/16"

Copyright reserved. This drawing and design is the property of M2 Landscape Architects and may not be reproduced or used for other projects without their permission.



#220 - 26 Lorne Mews
 New Westminster, British Columbia
 V3M 3L7
 Tel: 604.553.0044
 Fax: 604.553.0045
 Email: office@m2la.com

NO.	DATE	REVISION DESCRIPTION	DR.
8	2023-09-21	ISSUED FOR BP	GL
7	2023-09-09	ISSUED FOR DP	GL
6	2023-02-05	ISSUED FOR DP	GL
5	2022-08-16	ISSUED FOR DP	GL
4	2022-08-16	ISSUED FOR DP	GL
3	2022-08-01	ISSUED FOR DP	GL
2	2022-07-24	ISSUED FOR PRELIMINARY DESIGN	GL
1	2022-07-21	ISSUED FOR PRELIMINARY DESIGN	GL

SEAL:

PROJECT:
 HERITAGE REVITALIZATION AND
 NEW LOW ENERGY DUPLEX
 311 W 14TH STREET
 CITY OF NORTH VANCOUVER, BC

DRAWING TITLE:
LANDSCAPE SECTIONS

DATE: JULY, 21/22	DRAWING NUMBER:
SCALE: 1"= 3/16"	L7
DRAWN: GL	
DESIGN: GL	
CHK'D: MTLM	OF 10

M2LA PROJECT NUMBER: 22-030

22030-04



LANDSCAPE ARCHITECTURE

#220 - 26 Lorne Mews
 New Westminster, British Columbia
 V3M 3L7
 Tel: 604.553.0044
 Fax: 604.553.0045
 Email: office@m2la.com

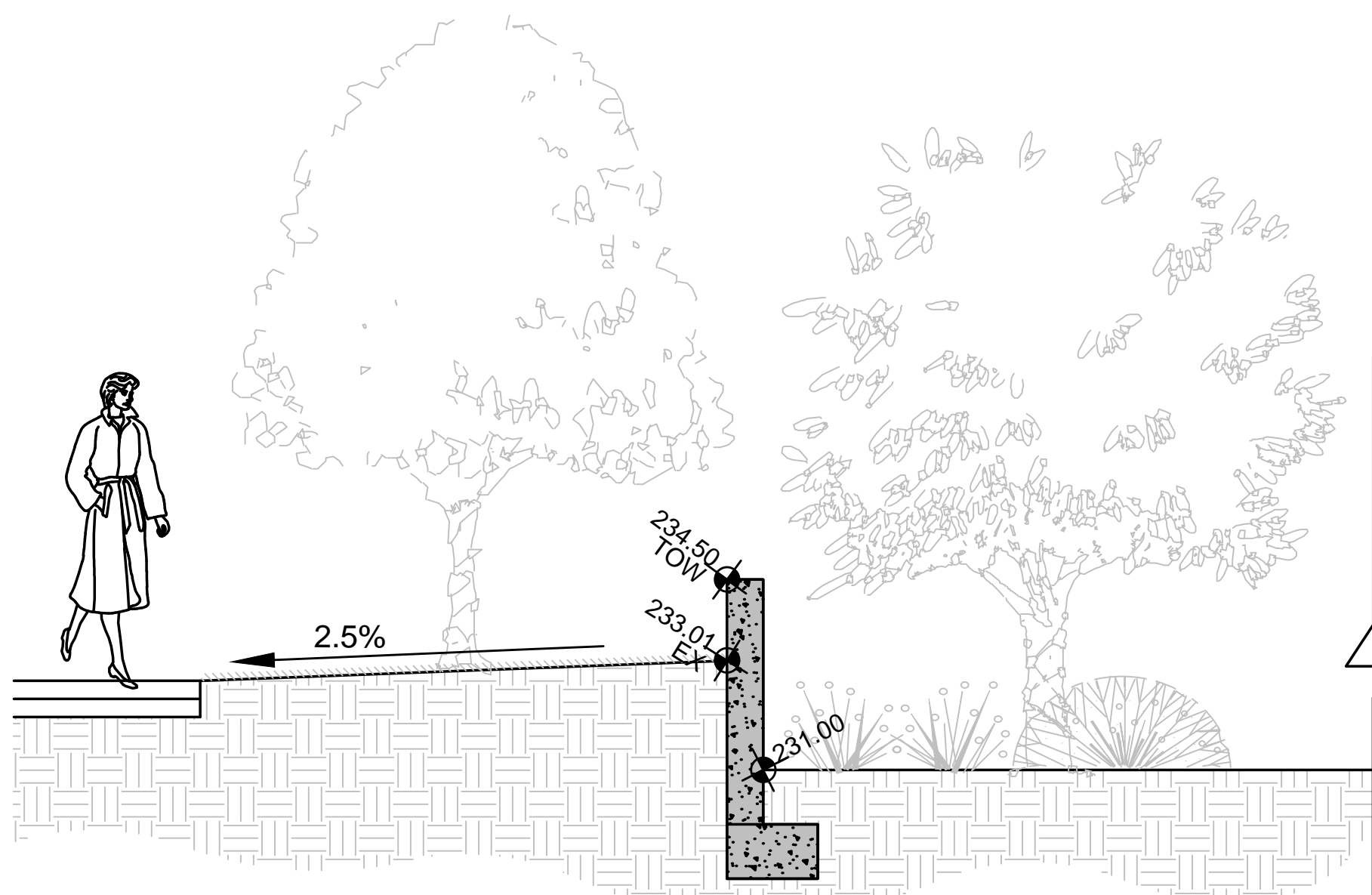
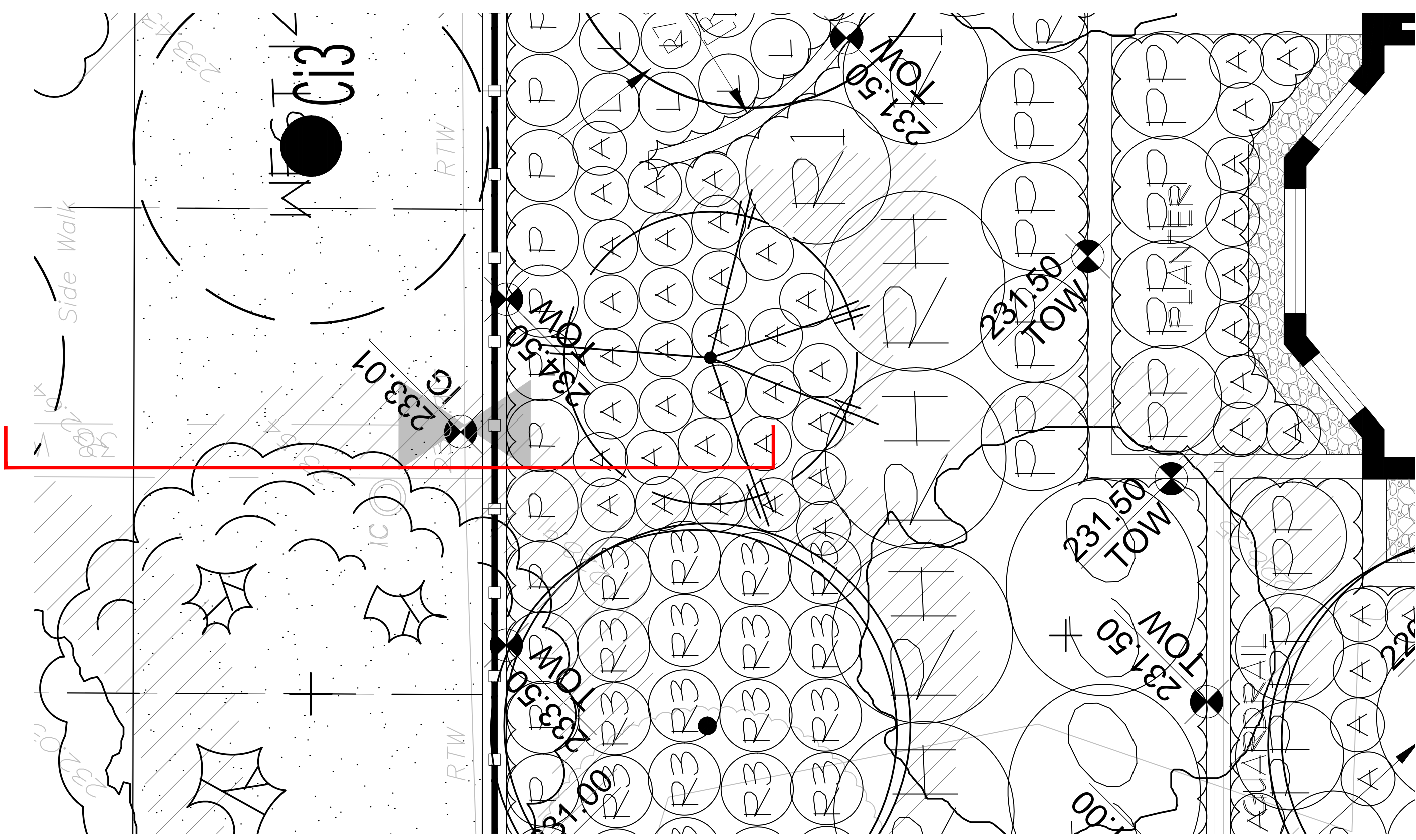
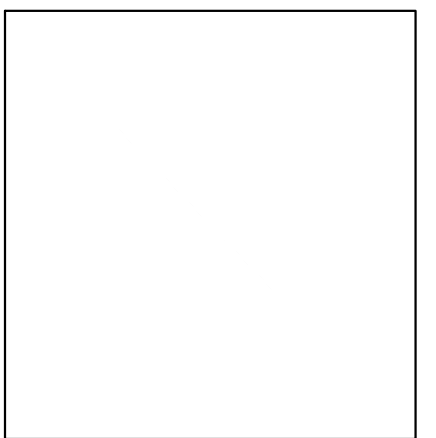

NOTE:
 REFER TO STRUCTURAL
 DRAWING FOR RETAINING
 WALL DETAILS.

01 NORTH RETAINING WALL
L8 SCALE: 1"=1/4"

NO.	DATE	REVISION DESCRIPTION	DR.
8	2023-09-21	ISSUED FOR BP	GL
7	2023-09-09	ISSUED FOR DP	GL
6	2023-02-15	ISSUED FOR DP	GL
5	2022-08-14	ISSUED FOR DP	GL
4	2022-08-14	ISSUED FOR DP	GL
3	2022-08-01	ISSUED FOR DP	GL
2	2022-07-24	ISSUED FOR PRELIMINARY DESIGN	GL
1	2022-07-21	ISSUED FOR PRELIMINARY DESIGN	GL

SEAL:

PROJECT:
 HERITAGE REVITALIZATION AND
 NEW LOW ENERGY DUPLEX
 311 W 14TH STREET
 CITY OF NORTH VANCOUVER, BC

DRAWING TITLE:
**LANDSCAPE
 SECTIONS**

DATE: JULY, 21, 22	DRAWING NUMBER:
SCALE: 1"= 3/16"	L8
DRAWN: GL	
DESIGN: GL	
CHK'D: MTLM	

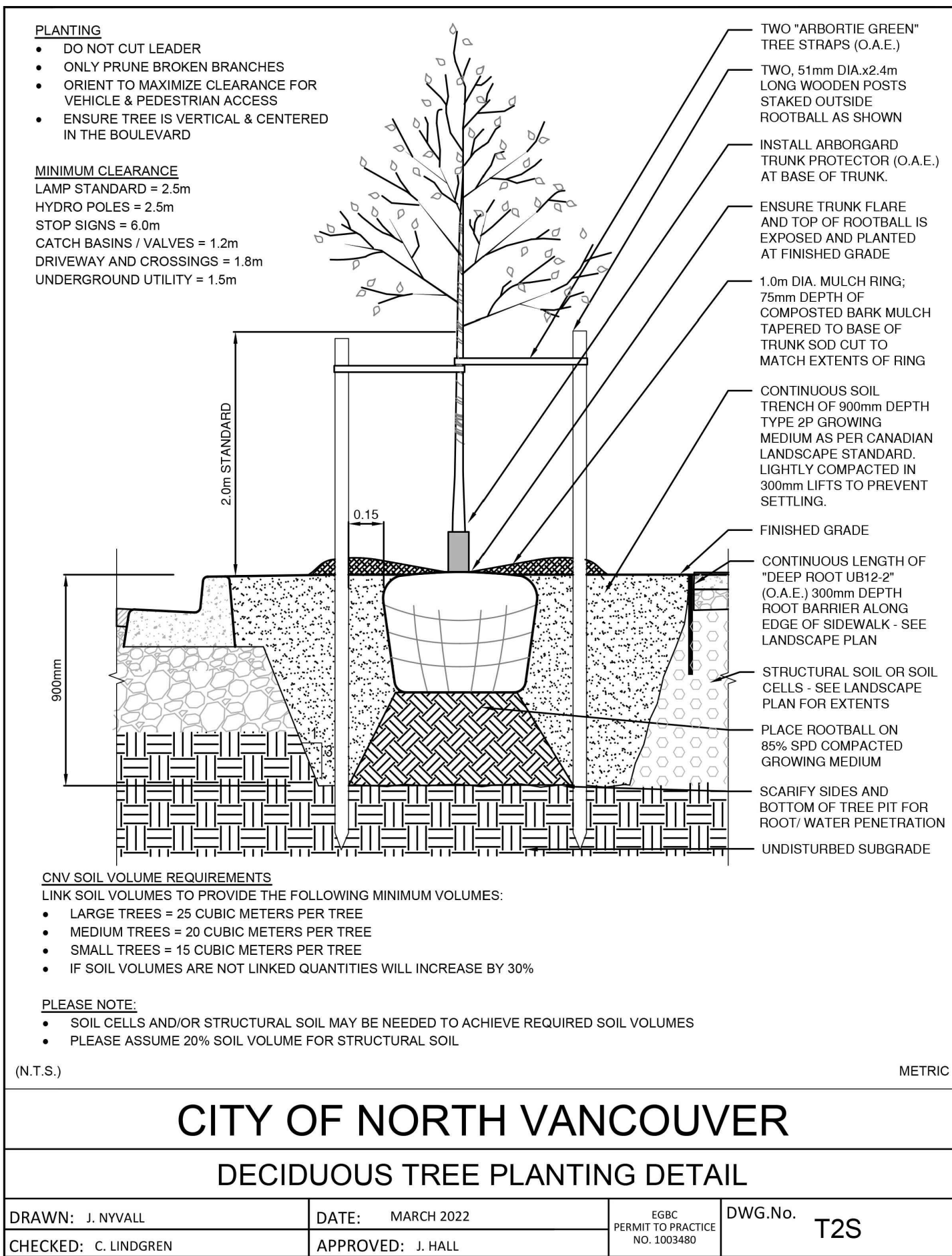

01 TREE PLANTING DETAIL
L9 SCALE: NTS

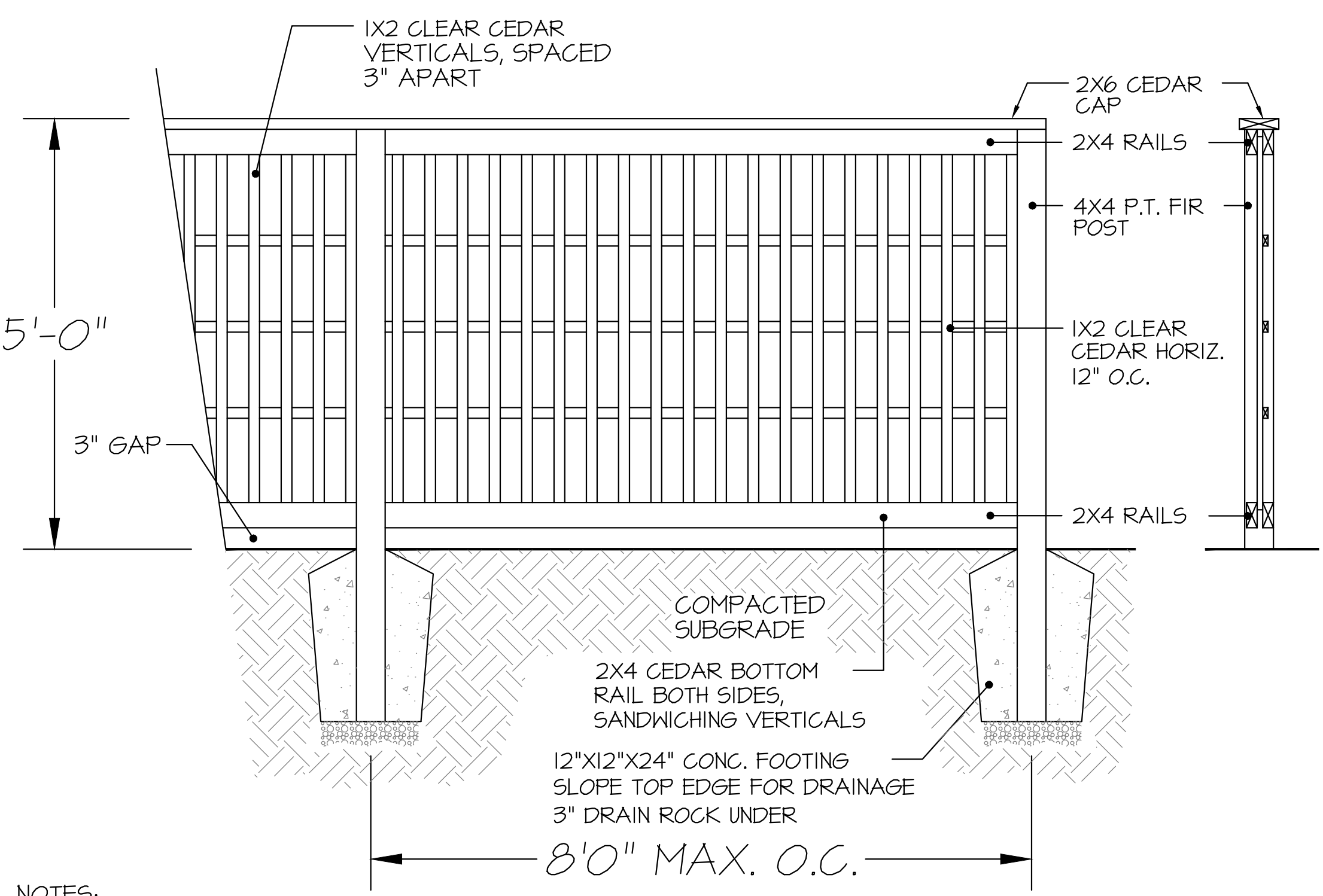

08 5 FT. HEIGHT PERIMETER FENCE
L9 SCALE: 3/4"=1'-0"

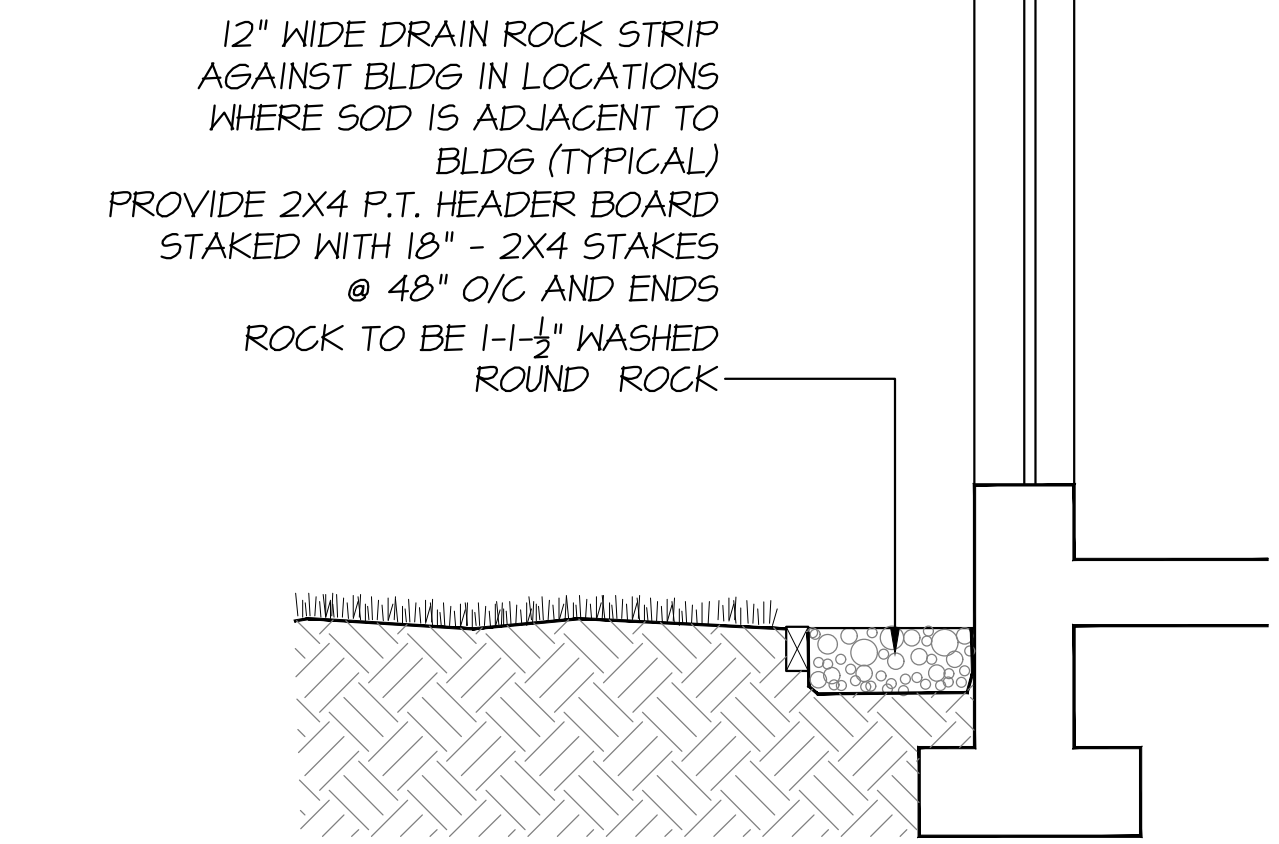

02 DRAIN ROCK STRIP AGAINST BUILDING
L9 SCALE: NTS

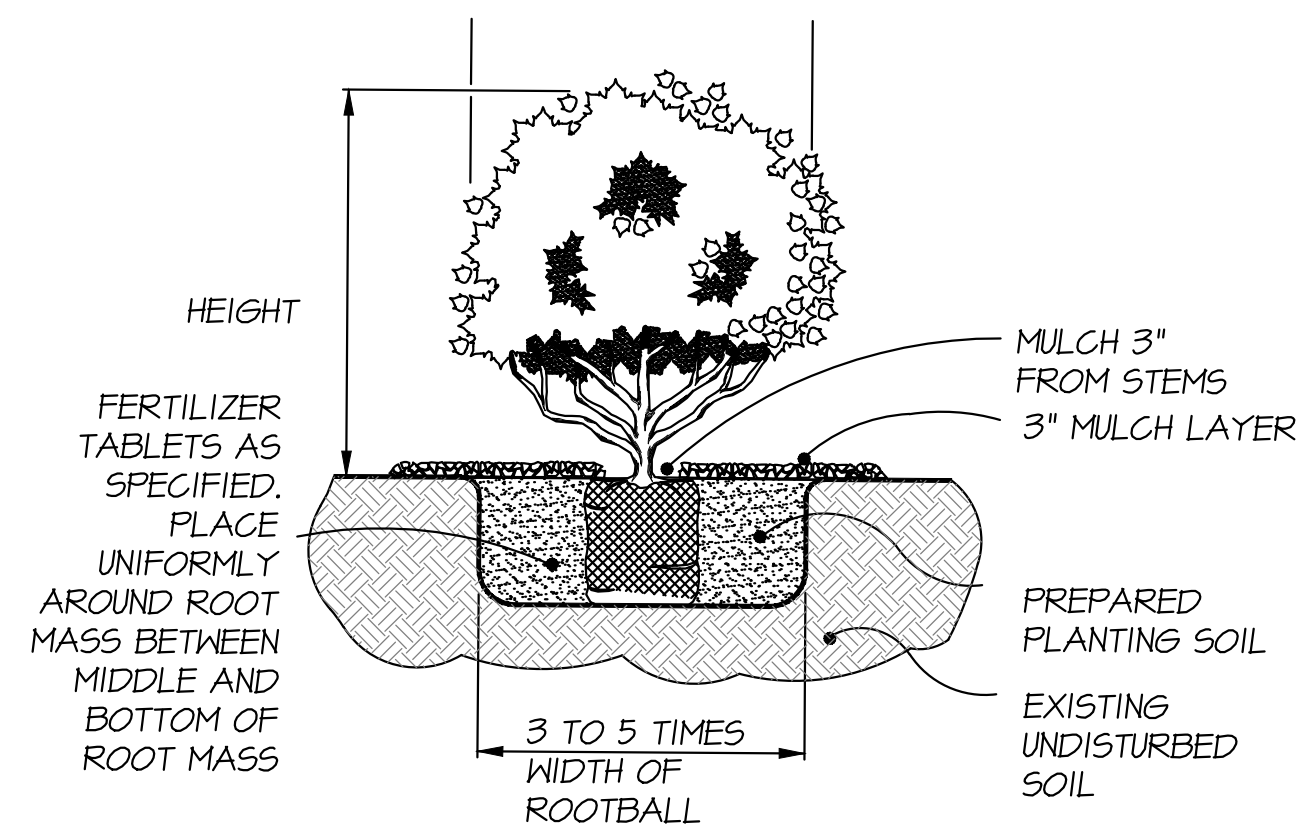

05 SHRUB PLANTING DETAIL
L9 SCALE: NTS

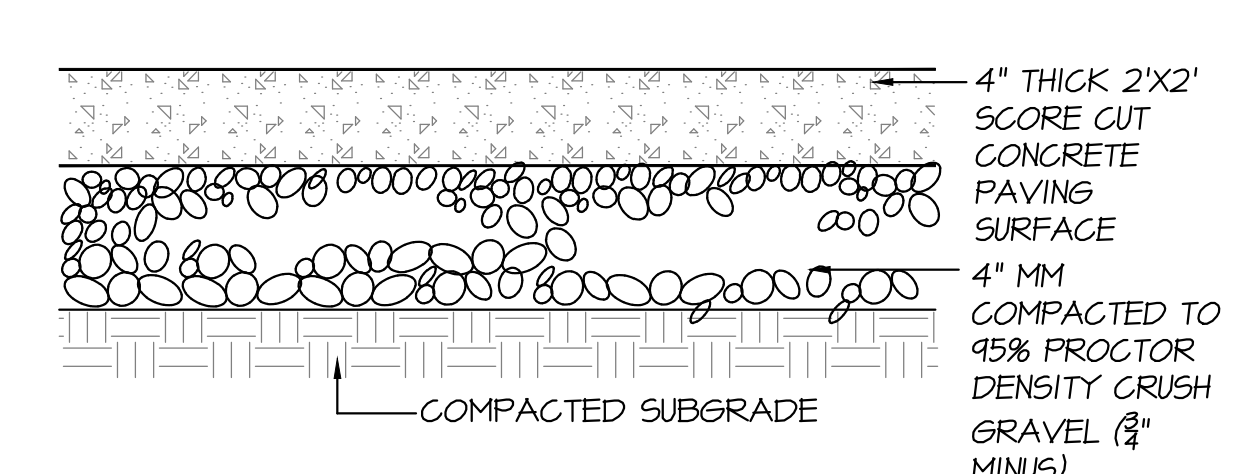

03 SCORE CUT CONCRETE AT GRADE DETAIL
L9 SCALE: 1/2"=1'-0"

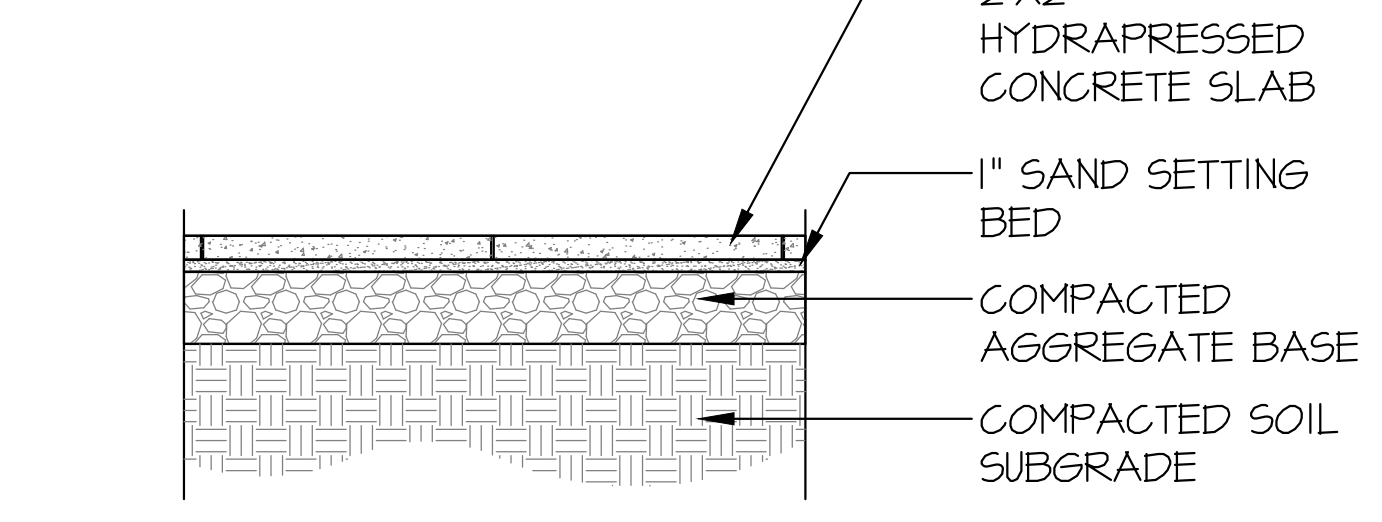

04 HYDRAPRESSED CONCRETE PAVERS AT GRADE
L9 SCALE: 3/4"=1'-0"

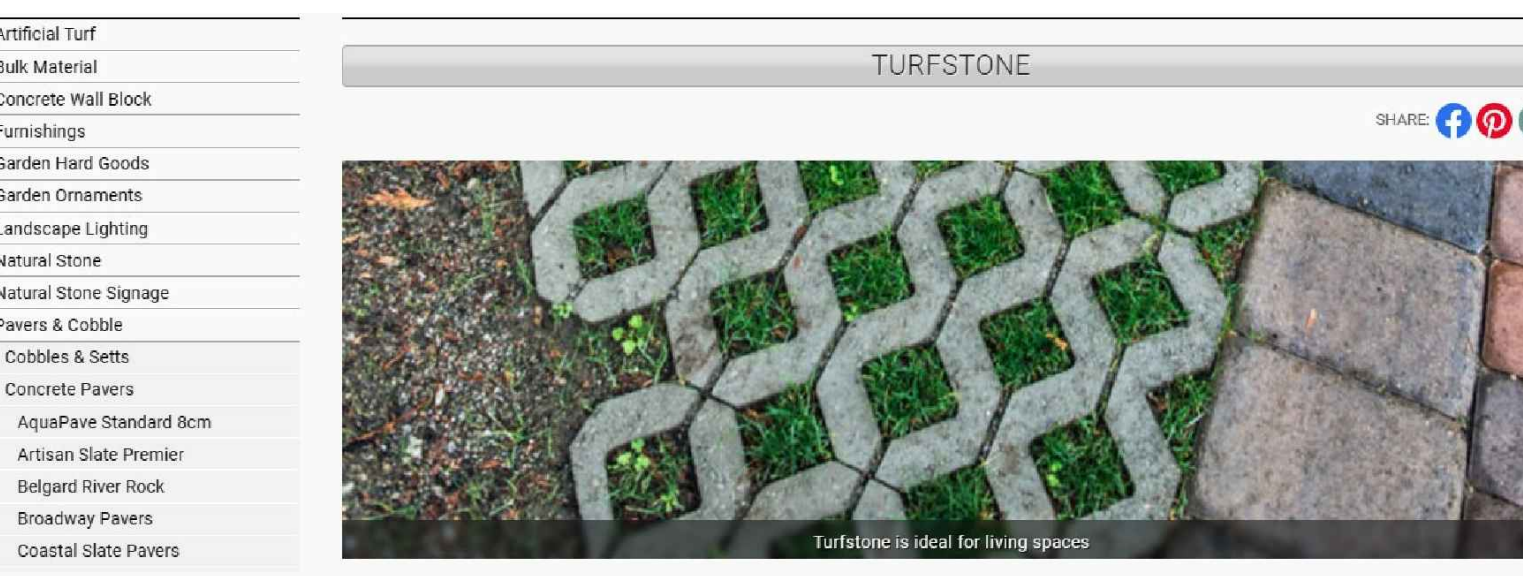

PART NUMBER	DIMENSIONS (W x L x D)	UNITS PER PALLET	SQ FT / PIECE	WEIGHT / PIECE	SO FT / PALLET	PALLET WEIGHT
PV090TURFGRM	23-5/8" x 15-3/4" x 3.5"D (600 x 400 x 90mm)	35	2.67	59 lb (31.29 kg)	91	2,415 lbs (1095 kg)

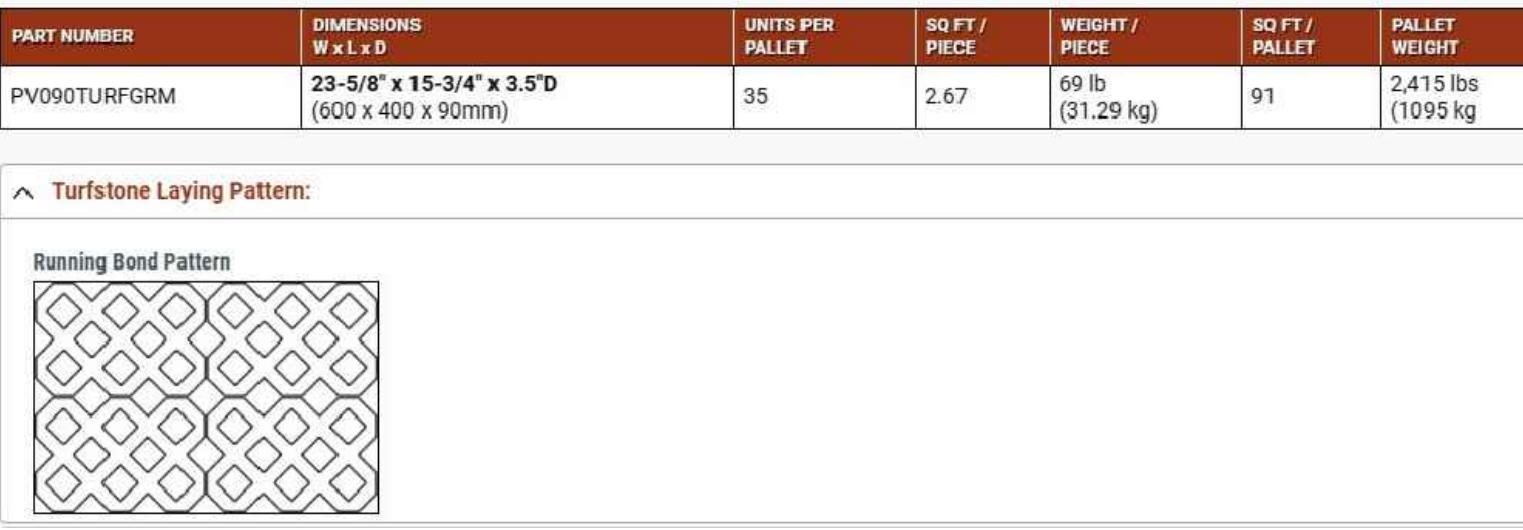

06 TURFSTONE BY NORTHWEST LANDSCAPE & STONE SUPPLY
L9



07 GREEN WALL WITH CABLE SYSTEM
L9

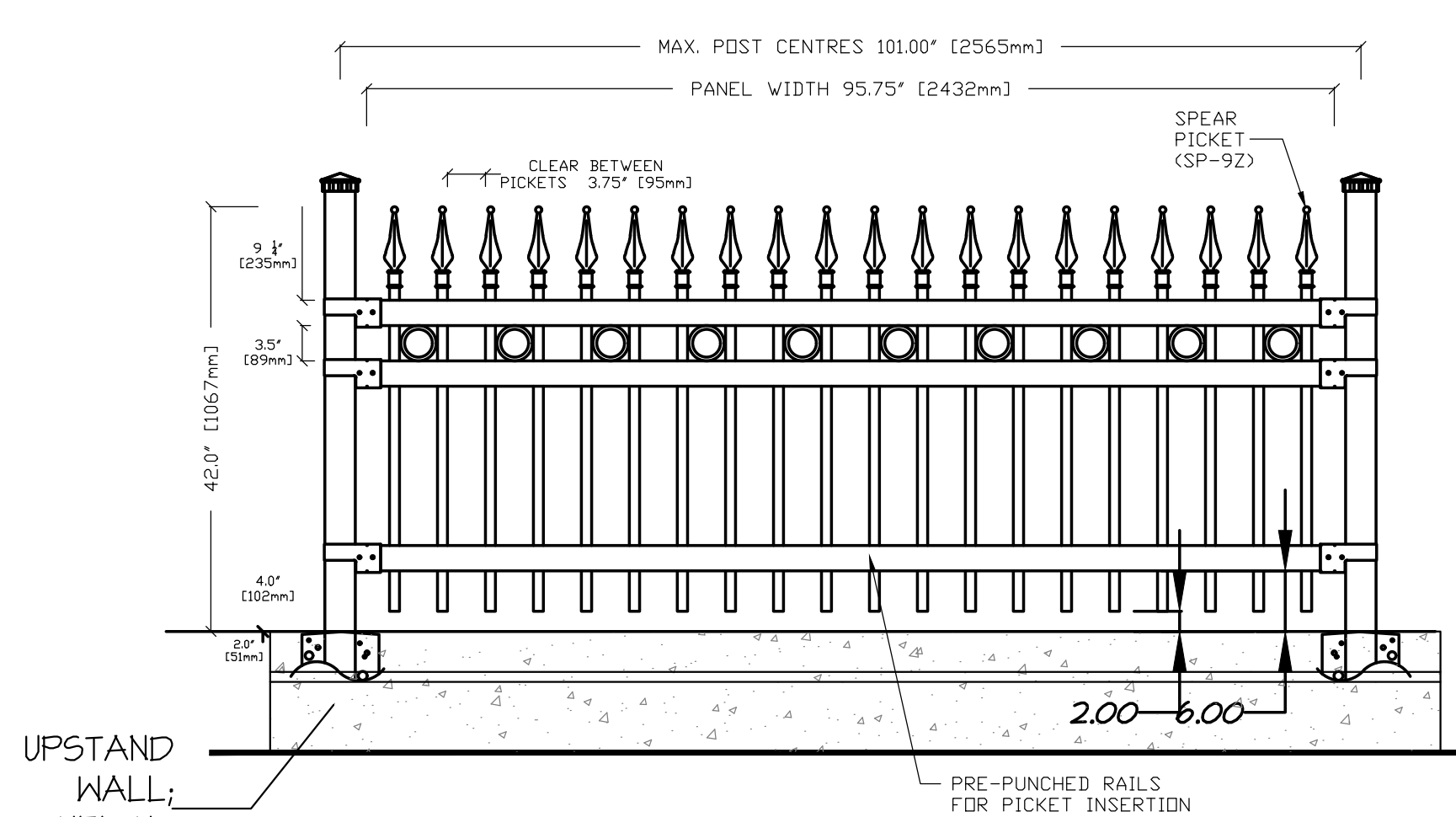

- FENCE MATERIAL POWDERCOAT ALUMINUM
- COLOUR OF METAL TO MATCH ARCH. RAILINGS, OR OTHER TO BE CHOSEN BY OWNER/ARCHITECT

09 42" HT. HERITAGE STYLE METAL PICKET FENCE
L9 SCALE: 3/4"=1'-0"



©Copyright reserved. This drawing and design is the property of M2 Landscape Architects and may not be reproduced or used for other projects without their permission.



#220 - 26 Lorne Mews
New Westminster, British Columbia
V3M 3L7
Tel: 604.553.0044
Fax: 604.553.0045
Email: office@m2la.com

NO.	DATE	REVISION DESCRIPTION	DR.
8	2023-09-21	ISSUED FOR BP	GL
7	2023-09-09	ISSUED FOR DP	GL
6	2023-02-05	ISSUED FOR DP	GL
5	2023-08-16	ISSUED FOR DP	GL
4	2023-08-16	ISSUED FOR DP	GL
3	2023-08-05	ISSUED FOR DP	GL
2	2023-07-24	ISSUED FOR PRELIMINARY DESIGN	GL
1	2022-07-28	ISSUED FOR PRELIMINARY DESIGN	GL

PROJECT:
HERITAGE REVITALIZATION AND
NEW LOW ENERGY DUPLEX
311 W 14TH STREET
CITY OF NORTH VANCOUVER, BC

DRAWING TITLE:
LANDSCAPE DETAILS

DATE: JUL 7, 21/22	DRAWING NUMBER:
SCALE: 1"= 3/16"	L9
DRAWN: GL	
DESIGN: GL	
CHK'D: MTLM	
M2LA PROJECT NUMBER:	22-030

