



LOT A
332 W 16TH, NORTH VANCOUVER

WWW.ROBERTBLANEYDESIGN.COM

604-626-6020

- A100 - SITE PLAN
- A101 - FOUNDATION PLAN
- A102 - BASEMENT FLOOR PLAN
- A103 - MAIN FLOOR PLAN
- A104 - 2ND FLOOR PLAN
- A105 - ROOF PLAN
- A106 - ELEVATIONS - NORTH & SOUTH
- A107 - ELEVATIONS - WEST
- A108 - ELEVATIONS - EAST
- A109 - SECTIONS & ASSEMBLIES
- A110 - DETAILS
- A111 - F.A.R
- A112 - GARAGE



PROJECT STATISTICS LOT A

CIVIC ADDRESS: 332 W 16TH ST NORTH VANCOUVER			
LEGAL DESCRIPTION: LOT 21 BLOCK 28 DISTRICT LOT 547 GROUP 1 WIND PLAN 1443			
ZONE: RS1			
SITE AREA (SQ FT): 3,490			
SITE WIDTH (FT): 24.98			
PROJECT STATISTICS			
HOUSE			
	PERMITTED/REQUIRED	PROPOSED	
IMPERIAL	METRIC	IMPERIAL	METRIC
ROOF HEIGHT	33.1	10.09	26.62
TOP PLATE	25.2	7.69	23.54
FRONT YARD SETBACK (S)	15	4.57	15
EAST SIDE YARD SETBACK	4	1.22	4
WEST SIDE YARD SETBACK	4	1.22	4
REAR YARD SETBACK (N)	47.89	14.60	57.02
17.38			
ACCESSORY BUILDING			
	PERMITTED/REQUIRED	PROPOSED	
IMPERIAL	METRIC	IMPERIAL	METRIC
BUILDING HEIGHT	15	4.57	13.9
FRONT YARD SETBACK TO HOUSE	10	3.05	29
EAST SIDE YARD SETBACK	2	0.61	2
WEST SIDE YARD SETBACK	2	0.61	10.91
REAR YARD SETBACK (S)	4	1.22	4
3.22			
FLOOR AREAS			
	PERMITTED/REQUIRED	PROPOSED	
FLOOR	AREA (SF)	AREA (M2)	AREA (SF)
BASEMENT	960.5	89.23	960.5
MAIN FLOOR	102.1	94.59	102.1
2ND FLOOR	813.3	75.56	813.3
ACCESSORY	290	26.94	290
TOTAL SLAB	1710	158.86	2905.9
278.32			
G.F.A. EXEMPTIONS			
	PERMITTED/REQUIRED	PROPOSED	
EXEMPTION	AREA (SF)	AREA (M2)	AREA (M2)
BASEMENT	960.5	89.23	960.5
ACCESSORY	290	26.94	290
TOTAL EXEMPT FROM G.F.A.	1250.5	116.17	1250.5
116.17			
G.F.A.			
	PERMITTED/REQUIRED	PROPOSED	
AREA (SF)	AREA (M2)	AREA (SF)	AREA (M2)
TOTAL G.F.A.	1710	158.86	1710
162.15			
SITE COVERAGE - HOUSE			
	PERMITTED/REQUIRED	PROPOSED	
AREA (SF)	AREA (M2)	AREA (SF)	AREA (M2)
AREA OF HOUSE	960.5	89.23	960.5
TOTAL SITE COVERAGE (MAX 30%)	1047.039	97.27	960.5
89.23			
SITE COVERAGE - COMBINED			
	PERMITTED/REQUIRED	PROPOSED	
AREA (SF)	AREA (M2)	AREA (SF)	AREA (M2)
AREA OF HOUSE	960.5	89.23	960.5
AREA OF ACCESSORY	290	26.94	290
TOTAL SITE COVERAGE (MAX 40%)	1396.052	129.69	1250.5
116.17			

PROJECT STATISTICS LOT B

CIVIC ADDRESS: 332 W 16TH ST NORTH VANCOUVER			
LEGAL DESCRIPTION: LOT 21 BLOCK 28 DISTRICT LOT 547 GROUP 1 WIND PLAN 1443			
ZONE: RS1			
SITE AREA (SQ FT): 3,490			
SITE WIDTH (FT): 24.98			
PROJECT STATISTICS			
HOUSE			
	PERMITTED/REQUIRED	PROPOSED	
IMPERIAL	METRIC	IMPERIAL	METRIC
ROOF HEIGHT	33.1	10.09	30.12
TOP PLATE	29.3	7.99	29.06
FRONT YARD SETBACK (S)	15	4.57	15
EAST SIDE YARD SETBACK	4	1.22	4
WEST SIDE YARD SETBACK	4	1.22	4
REAR YARD SETBACK (N)	47.89	14.60	57.02
17.38			
ACCESSORY BUILDING			
	PERMITTED/REQUIRED	PROPOSED	
IMPERIAL	METRIC	IMPERIAL	METRIC
BUILDING HEIGHT	15	4.57	15
FRONT YARD SETBACK TO HOUSE	10	3.05	29.01
EAST SIDE YARD SETBACK	2	0.61	10.91
WEST SIDE YARD SETBACK	2	0.61	2
REAR YARD SETBACK (S)	4	1.22	4
3.22			
FLOOR AREAS			
	PERMITTED/REQUIRED	PROPOSED	
FLOOR	AREA (SF)	AREA (M2)	AREA (SF)
BASEMENT	960.5	89.23	960.5
MAIN FLOOR	102.1	94.59	102.1
2ND FLOOR	813.3	75.56	813.3
ACCESSORY	290	26.94	290
TOTAL SLAB	1710	158.86	2905.9
278.32			
G.F.A. EXEMPTIONS			
	PERMITTED/REQUIRED	PROPOSED	
EXEMPTION	AREA (SF)	AREA (M2)	AREA (M2)
BASEMENT	960.5	89.23	960.5
ACCESSORY	290	26.94	290
TOTAL EXEMPT FROM G.F.A.	1250.5	116.17	1250.5
116.17			
G.F.A.			
	PERMITTED/REQUIRED	PROPOSED	
AREA (SF)	AREA (M2)	AREA (SF)	AREA (M2)
TOTAL G.F.A.	1710	158.86	1710
162.15			
SITE COVERAGE - HOUSE			
	PERMITTED/REQUIRED	PROPOSED	
AREA (SF)	AREA (M2)	AREA (SF)	AREA (M2)
AREA OF HOUSE	960.5	89.23	960.5
TOTAL SITE COVERAGE (MAX 30%)	1047.039	97.27	960.5
89.23			
SITE COVERAGE - COMBINED			
	PERMITTED/REQUIRED	PROPOSED	
AREA (SF)	AREA (M2)	AREA (SF)	AREA (M2)
AREA OF HOUSE	960.5	89.23	960.5
AREA OF ACCESSORY	290	26.94	290
TOTAL SITE COVERAGE (MAX 40%)	1396.052	129.69	1250.5
116.17			

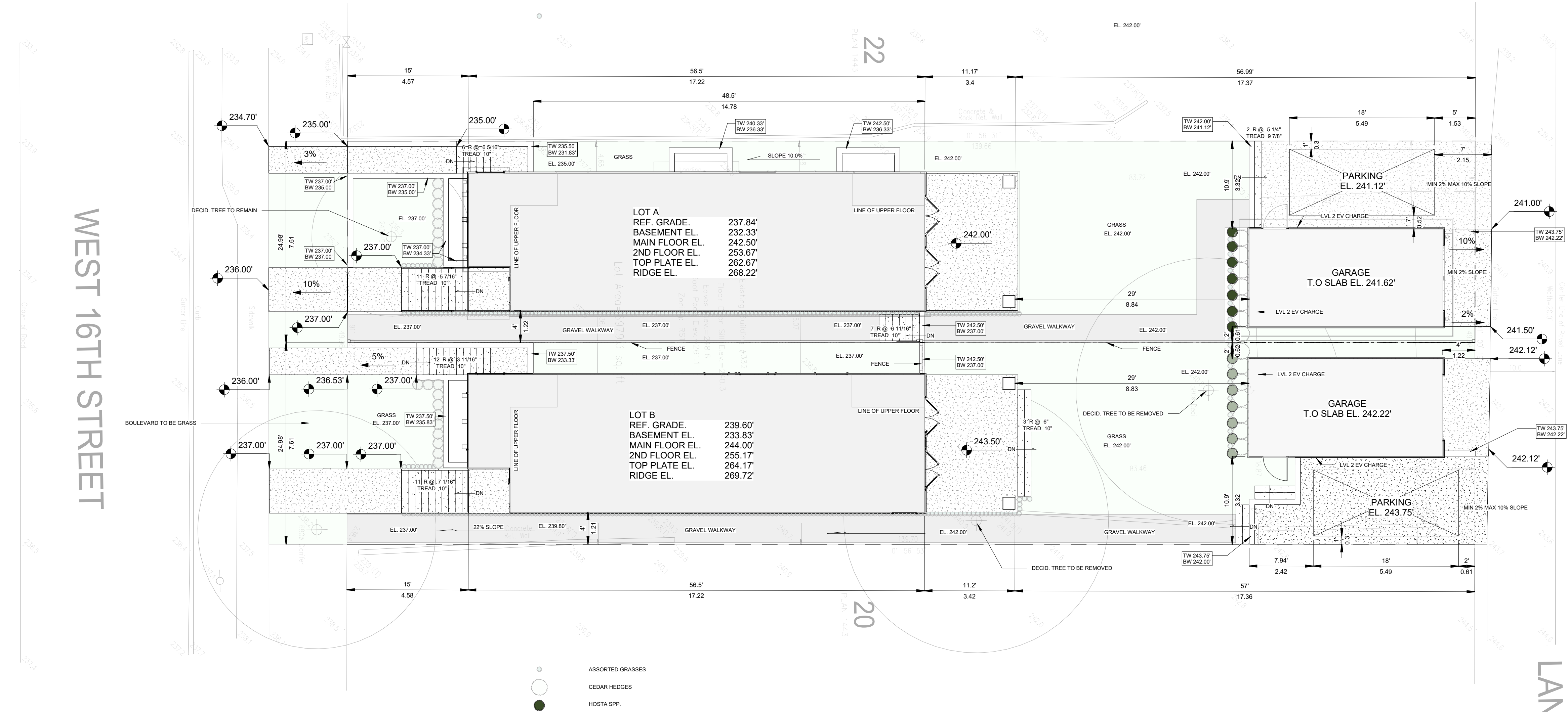

1 SITE
1/8" = 1'-0"

REVISIONS
ISSUED FOR: 2023-06-07
REVIEW SET: 8:11:46 AM

PROJECT:
LOT A
332 W 16TH ST.
NORTH VANCOUVER

DRAWING TITLE:
SITE PLAN

SHEET:
A100

DRAWN BY:
jp

24X36 SCALE:
1/8" = 1'-0"

PROJECT NUMBER:
038721

START DATE:
05.22.23

COPYRIGHT RESERVED.

THIS DRAWING AND DESIGN ARE AND SHALL AT ALL TIMES REMAIN THE EXCLUSIVE PROPERTY OF ROBERT BLANEY DESIGN AND CANNOT BE USED OR REPRODUCED WITHOUT WRITTEN CONSENT. WRITTEN DIMENSIONS SHALL HAVE PRECEDENCE OVER SCALED DIMENSIONS. CONTRACTOR SHALL VERIFY AND SHALL BE RESPONSIBLE FOR ALL DIMENSIONS AND CONDITIONS ON THE JOB AND THIS OFFICE SHALL BE INFORMED OF ANY VARIATIONS FROM THE DIMENSIONS AND CONDITIONS AS SHOWN ON THIS DRAWING. CONTRACTORS SHALL ENSURE THAT ALL CONSTRUCTION WILL COMPLY TO ALL APPLICABLE BUILDING CODES. ROBERT BLANEY DESIGN WILL NOT ACCEPT RESPONSIBILITY FOR VARIATIONS OR MODIFICATION OF THESE PLANS.



5464 PATRICIA BAY HIGHWAY,
VICTORIA BC V8Y 2N9

(604) 626-6020
ROBERTBLANEYDESIGN@GMAIL.COM
WWW.ROBERTBLANEYDESIGN.COM

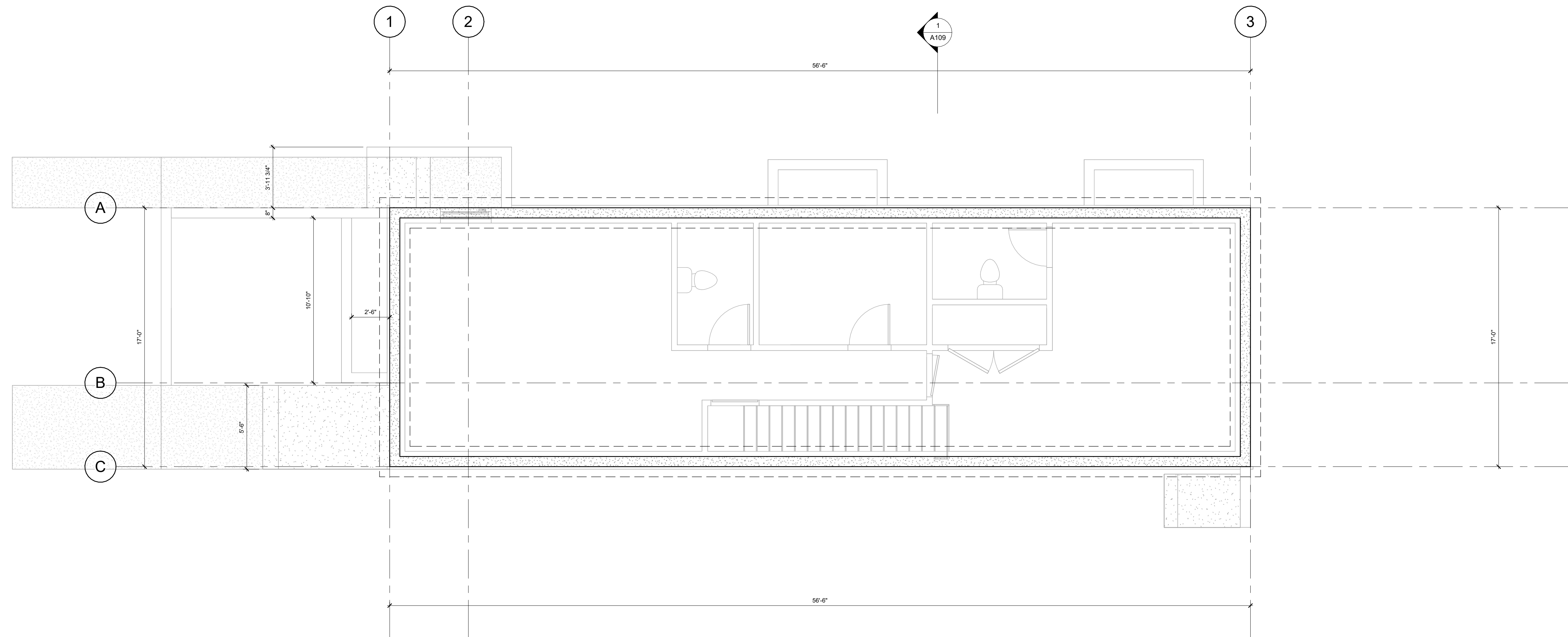
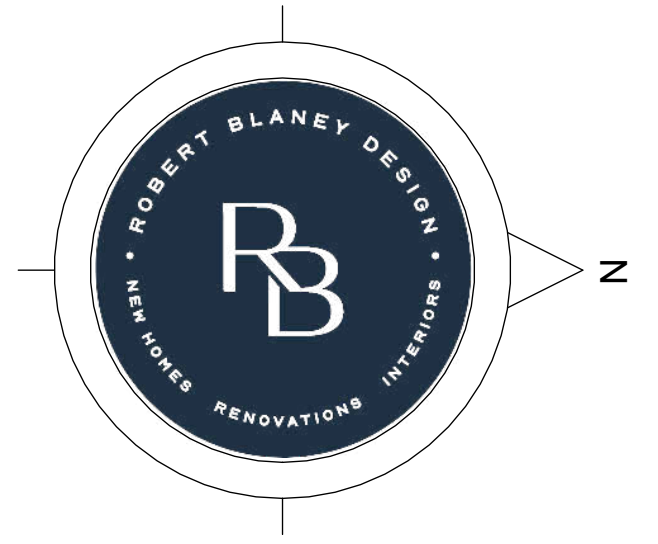

1 FOUNDATION
1/4" = 1'-0"

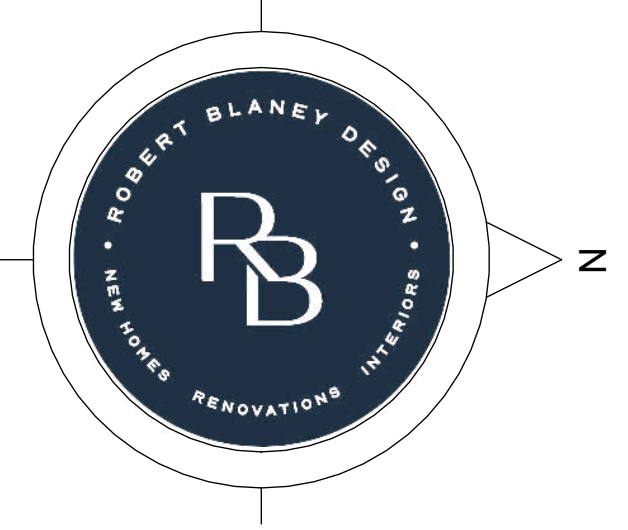

Window Schedule BASEMENT				
Level	Mark	Width	Height	Sill Height
BASEMENT	W14	5'	3'	5'
BASEMENT	W15	5'	3'	5'
BASEMENT	W16	7'	6'	3'

Door Schedule BASEMENT			
Level	Mark	Width	Height
BASEMENT	14	2.67'	6.67'
BASEMENT	15	2.67'	6.67'
BASEMENT	17	2.67'	6.67'
BASEMENT	18	3'	6.67'
BASEMENT	19	3'	8'
BASEMENT	23	2.5'	8'
BASEMENT	24	6'	8'

Room Schedule BASEMENT			
Level	Name	Area	Perimeter
BASEMENT	BATH	40 ft ²	26'
BASEMENT	BATH	38 ft ²	25'
BASEMENT	BED 2	88 ft ²	38'
BASEMENT	DINING	69 ft ²	34.23'
BASEMENT	FOYER	50 ft ²	28.4'
BASEMENT	GAMES	225 ft ²	89.72'
BASEMENT	KITCHEN	63 ft ²	32'
BASEMENT	LIVING	93 ft ²	38.95'
BASEMENT	MECH	20 ft ²	20.25'

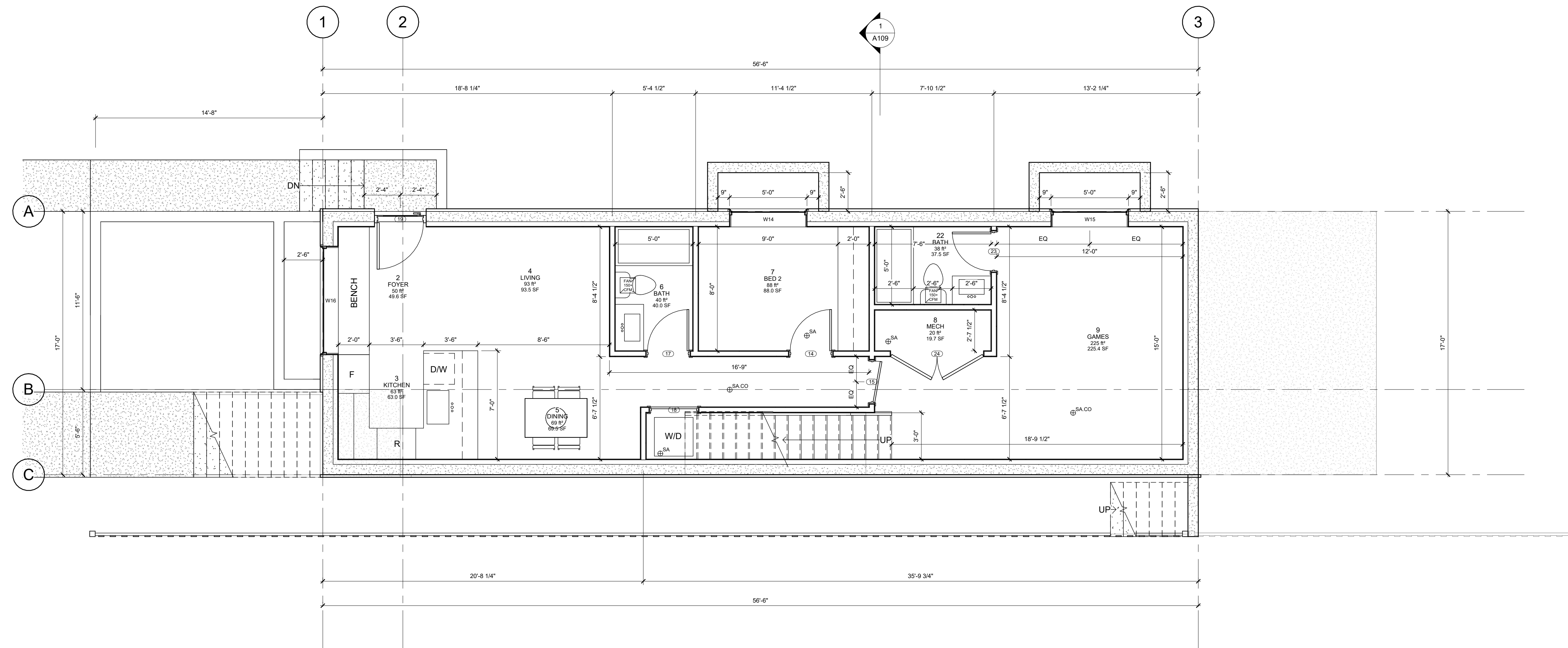

1 BASEMENT
1/4" = 1'-0"



5464 PATRICIA BAY HIGHWAY,
VICTORIA BC V8Y 2N9

(604) 626-6020
ROBERTBLANEYDESIGN@GMAIL.COM
WWW.ROBERTBLANEYDESIGN.COM

REVISIONS
ISSUED FOR:
REVIEW SET:

2023-06-07
8:11:48 AM

PROJECT:
LOT A
332 W 16TH ST.
NORTH VANCOUVER

DRAWING TITLE:
BASEMENT FLOOR PLAN

SHEET:

A102

DRAWN BY:

jp

24X36 SCALE:

1/4" = 1'-0"

PROJECT NUMBER:

038721

START DATE:

05.22.23

COPYRIGHT RESERVED.

THIS DRAWING AND DESIGN ARE AND SHALL AT ALL TIMES REMAIN THE EXCLUSIVE PROPERTY OF ROBERT BLANEY DESIGN AND CANNOT BE USED OR REPRODUCED WITHOUT WRITTEN CONSENT. WRITTEN DIMENSIONS SHALL HAVE PRECEDENCE OVER SCALED DIMENSIONS. CONTRACTOR SHALL VERIFY AND SHALL BE RESPONSIBLE FOR ALL DIMENSIONS AND CONDITIONS ON THE JOB AND THIS OFFICE SHALL BE INFORMED OF ANY VARIATIONS FROM THE DIMENSIONS AND CONDITIONS AS SHOWN ON THIS DRAWING. CONTRACTORS SHALL ENSURE THAT ALL CONSTRUCTION WILL COMPLY TO ALL APPLICABLE BUILDING CODES. ROBERT BLANEY DESIGN WILL NOT ACCEPT RESPONSIBILITY FOR VARIATIONS OR MODIFICATION OF THESE PLANS.

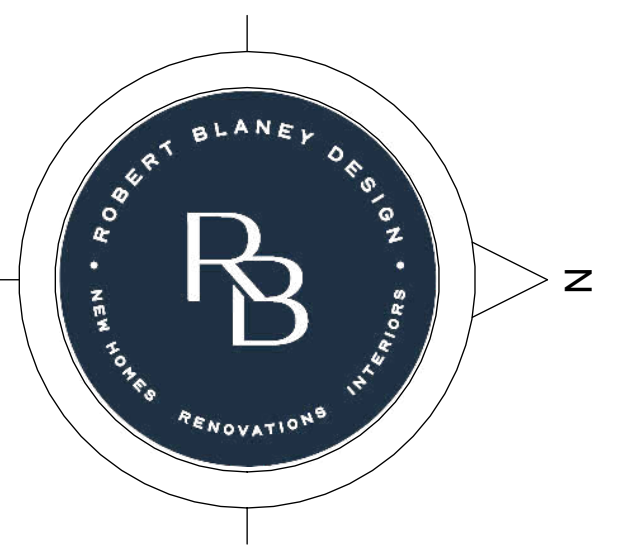

Window Schedule MAIN FLOOR				
Level	Mark	Width	Height	Sill Height
MAIN FLOOR	W2	7'	7'	2'
MAIN FLOOR	W3	3.5'	7'	1'
MAIN FLOOR	W4	4.5'	4.5'	3.5'
MAIN FLOOR	W5	3'	6'	3'

Door Schedule MAIN FLOOR			
Level	Mark	Width	Height
MAIN FLOOR	4	3.5'	9'
MAIN FLOOR	5	5'	8'
MAIN FLOOR	7	5'	8'
MAIN FLOOR	8	2.5'	8'

Room Schedule MAIN FLOOR			
Level	Name	Area	Perimeter
MAIN FLOOR	LIVING	122 ft ²	44.25'
MAIN FLOOR	Room	41 ft ²	26.66'
MAIN FLOOR	DINING	130 ft ²	45.75'
MAIN FLOOR	BATH	23 ft ²	19.08'
MAIN FLOOR	KITCHEN	255 ft ²	65.83'
MAIN FLOOR	FAMILY	178 ft ²	57.91'

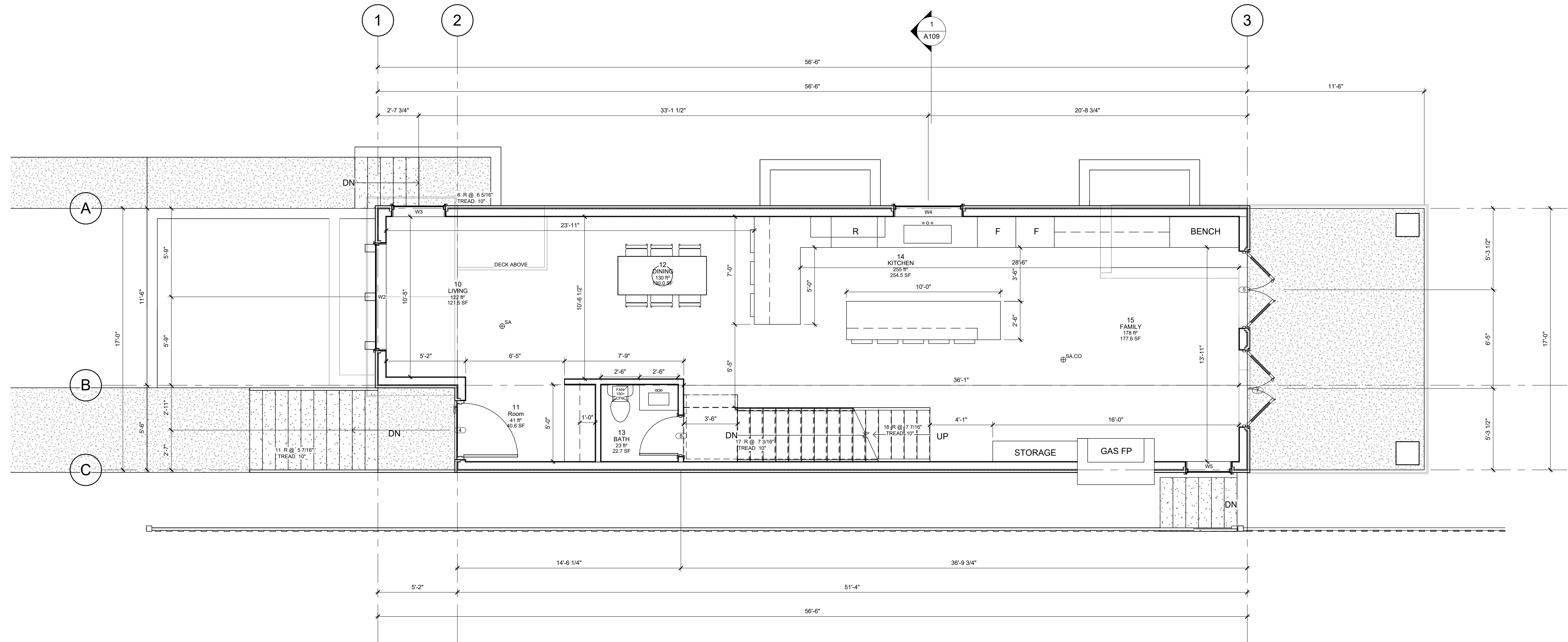

1 MAIN FLOOR
1/4" = 1'-0"



5464 PATRICIA BAY HIGHWAY,
VICTORIA BC V8Y 2N9

(604) 626-6020
ROBERTBLANEYDESIGN@GMAIL.COM
WWW.ROBERTBLANEYDESIGN.COM

REVISIONS
ISSUED FOR: 2023-06-07
REVIEW SET: 8:11:48 AM

PROJECT:
LOT A
332 W 16TH ST.
NORTH VANCOUVER

DRAWING TITLE:
MAIN FLOOR PLAN

SHEET:

A103

DRAWN BY:
jpb

24X36 SCALE:
1/4" = 1'-0"

START DATE:
05.22.23

PROJECT NUMBER:
038721

COPYRIGHT RESERVED.

THIS DRAWING AND DESIGN ARE AND SHALL AT ALL TIMES REMAIN THE EXCLUSIVE PROPERTY OF ROBERT BLANEY DESIGN AND CANNOT BE USED OR REPRODUCED WITHOUT WRITTEN CONSENT. WRITTEN DIMENSIONS SHALL HAVE PRECEDENCE OVER SCALED DIMENSIONS. CONTRACTOR SHALL VERIFY AND SHALL BE RESPONSIBLE FOR ALL DIMENSIONS AND CONDITIONS ON THE JOB AND THIS OFFICE SHALL BE INFORMED OF ANY VARIATIONS FROM THE DIMENSIONS AND CONDITIONS AS SHOWN ON THIS DRAWING. CONTRACTORS SHALL ENSURE THAT ALL CONSTRUCTION WILL COMPLY TO ALL APPLICABLE BUILDING CODES. ROBERT BLANEY DESIGN WILL NOT ACCEPT RESPONSIBILITY FOR VARIATIONS OR MODIFICATION OF THESE PLANS.



Window Schedule 2ND FLOOR				
Level	Mark	Width	Height	Sill Height
2ND FLOOR	W8	6'	6'	3'
2ND FLOOR	W10	3'	2'	6'
2ND FLOOR	W11	4'	2'	6'
2ND FLOOR	W12	2.5'	7'	1'
2ND FLOOR	W13	7'	7'	1'
2ND FLOOR	W17	4'	7'	1'

Door Schedule 2ND FLOOR			
Level	Mark	Width	Height
2ND FLOOR	2	2.5'	6.67'
2ND FLOOR	3	3'	6.67'
2ND FLOOR	9	3'	6.67'
2ND FLOOR	10	3'	8'
2ND FLOOR	11	2.5'	6.67'
2ND FLOOR	12	3'	6.67'
2ND FLOOR	22	2.33'	8'

Room Schedule 2ND FLOOR			
Level	Name	Area	Perimeter
2ND FLOOR	BATH	39 ft²	25.42'
2ND FLOOR	BED 1	126 ft²	54.08'
2ND FLOOR	BED 2	108 ft²	42.08'
2ND FLOOR	PRIMARY	215 ft²	67.42'
2ND FLOOR	PRIMARY BATH	48 ft²	32.08'

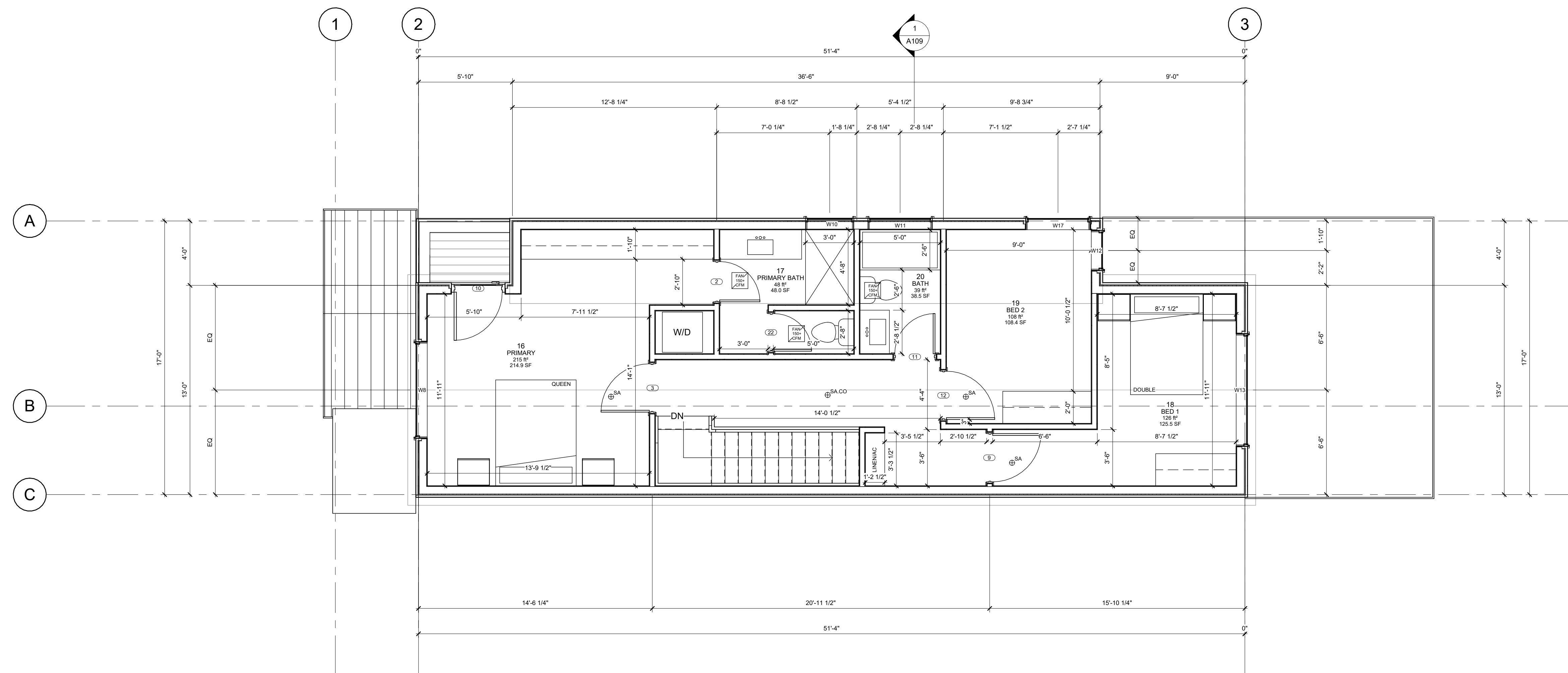

1 2ND FLOOR
1/4" = 1'-0"



5464 PATRICIA BAY HIGHWAY,
VICTORIA BC V8Y 2N9

(604) 626-6020
ROBERTBLANEYDESIGN@GMAIL.COM
WWW.ROBERTBLANEYDESIGN.COM

REVISIONS
ISSUED FOR:
REVIEW SET:

2023-06-07
8:11:49 AM

PROJECT:
LOT A
332 W 16TH ST.
NORTH VANCOUVER

DRAWING TITLE:
2ND FLOOR PLAN

SHEET:

A104

DRAWN BY:
jp

24X36 SCALE:
1/4" = 1'-0"

START DATE:
05.22.23

PROJECT NUMBER:
038721

COPYRIGHT RESERVED.

THIS DRAWING AND DESIGN ARE AND SHALL AT ALL TIMES REMAIN THE EXCLUSIVE PROPERTY OF ROBERT BLANEY DESIGN AND CANNOT BE USED OR REPRODUCED WITHOUT WRITTEN CONSENT. WRITTEN DIMENSIONS SHALL HAVE PRECEDENCE OVER SCALED DIMENSIONS. CONTRACTOR SHALL VERIFY AND SHALL BE RESPONSIBLE FOR ALL DIMENSIONS AND CONDITIONS ON THE JOB AND THIS OFFICE SHALL BE INFORMED OF ANY VARIATIONS FROM THE DIMENSIONS AND CONDITIONS AS SHOWN ON THIS DRAWING. CONTRACTORS SHALL ENSURE THAT ALL CONSTRUCTION WILL COMPLY TO ALL APPLICABLE BUILDING CODES. ROBERT BLANEY DESIGN WILL NOT ACCEPT RESPONSIBILITY FOR VARIATIONS OR MODIFICATION OF THESE PLANS.

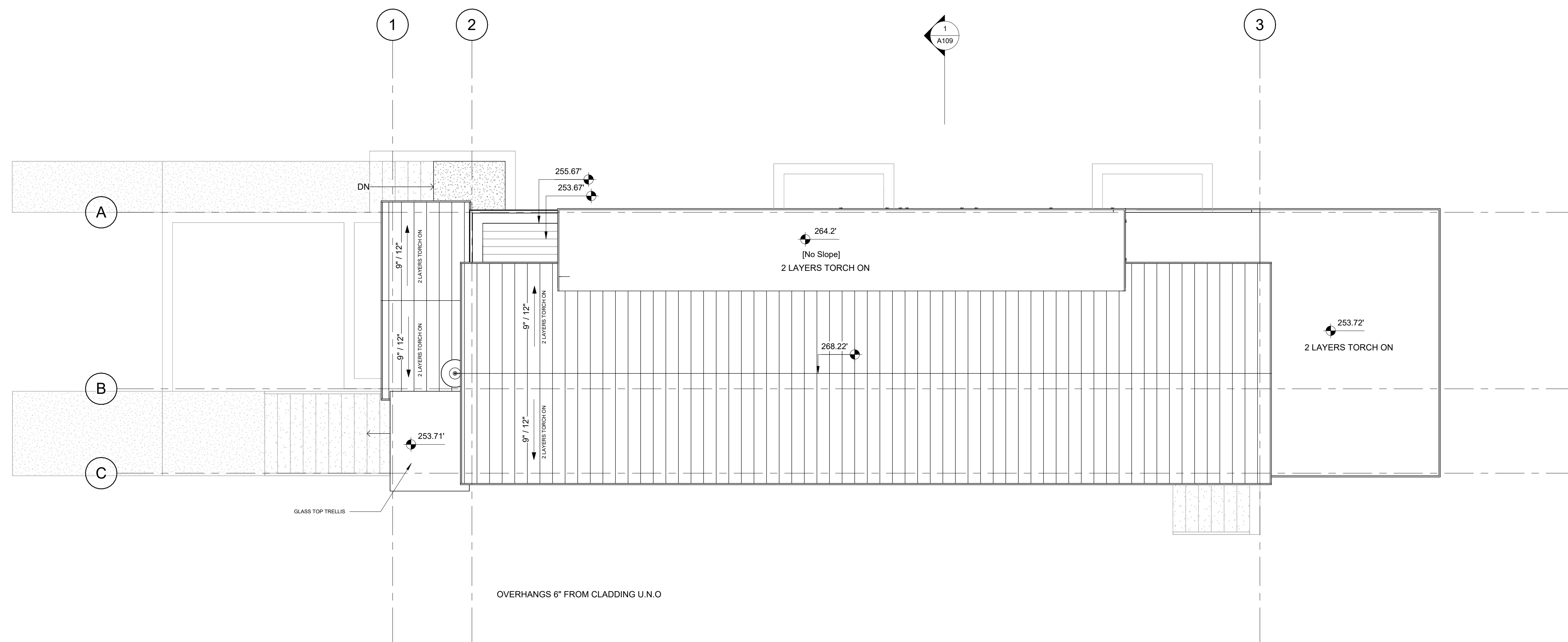

1 ROOF
1/4" = 1'-0"



1 NORTH
1/4" = 1'-0"

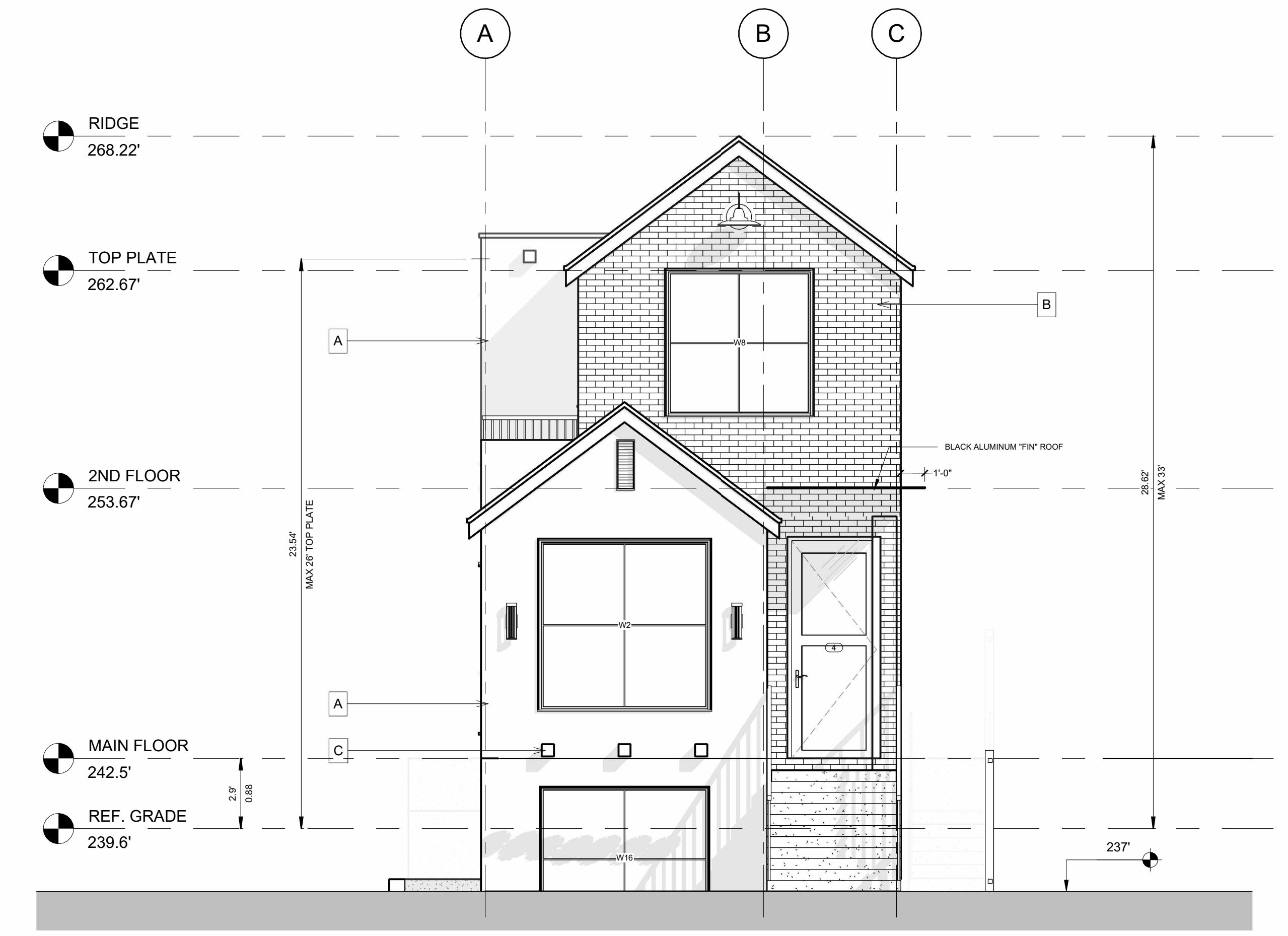

2 SOUTH
1/4" = 1'-0"

Window Schedule ALL FLOORS					
Level	Mark	Sill Height	Width	Height	Area
MAIN FLOOR	W2	2'	7'	7'	49 ft ²
MAIN FLOOR	W3	1'	3.5'	7'	25 ft ²
MAIN FLOOR	W4	3.5'	4.5'	4.5'	20 ft ²
MAIN FLOOR	W5	3'	3'	6'	18 ft ²
2ND FLOOR	W8	3'	6'	6'	36 ft ²
2ND FLOOR	W10	6'	3'	2'	6 ft ²
2ND FLOOR	W11	6'	4'	2'	8 ft ²
2ND FLOOR	W12	1'	2.5'	7'	18 ft ²
2ND FLOOR	W13	1'	7'	7'	49 ft ²
BASEMENT	W14	5'	5'	3'	15 ft ²
BASEMENT	W15	5'	5'	3'	15 ft ²
BASEMENT	W16	3'	7'	6'	42 ft ²
2ND FLOOR	W17	1'	4'	7'	28 ft ²

Door Schedule EXTERIOR				
Level	Mark	Width	Height	Function
MAIN FLOOR	4	3.5'	9'	Exterior
MAIN FLOOR	5	5'	8'	Exterior
MAIN FLOOR	7	5'	8'	Exterior
2ND FLOOR	10	3'	8'	Exterior
BASEMENT	19	3'	8'	Exterior
GARAGE SLAB	25	8'	8'	Exterior
GARAGE SLAB	26	3'	8'	Exterior

LEGEND	
STUCCO (WHITE)	A
BRICK (WHITE)	B
WOOD (DARK STAIN)	C
WOOD (WHITE)	D
STANDING SEAM METAL (CHARCOAL)	E
STONE (TBD)	F



5464 PATRICIA BAY HIGHWAY,
VICTORIA BC V8Y 2N9

(604) 626-6020
ROBERTBLANEYDESIGN@GMAIL.COM
WWW.ROBERTBLANEYDESIGN.COM

REVISIONS
ISSUED FOR:
REVIEW SET:

2023-06-07
8:11:55 AM

PROJECT:
LOT A
332 W 16TH ST.
NORTH VANCOUVER

DRAWING TITLE:
ELEVATIONS - NORTH &
SOUTH

SHEET:

A106

DRAWN BY:
jp

24X36 SCALE:
1/4" = 1'-0"

PROJECT NUMBER:
038721

START DATE:
05.22.23

COPYRIGHT RESERVED.

THIS DRAWING AND DESIGN ARE AND SHALL AT ALL TIMES REMAIN THE EXCLUSIVE PROPERTY OF ROBERT BLANEY DESIGN AND CANNOT BE USED OR REPRODUCED WITHOUT WRITTEN CONSENT. WRITTEN DIMENSIONS SHALL HAVE PRECEDENCE OVER SCALED DIMENSIONS. CONTRACTOR SHALL VERIFY AND SHALL BE RESPONSIBLE FOR ALL DIMENSIONS AND CONDITIONS ON THE JOB AND THIS OFFICE SHALL BE INFORMED OF ANY VARIATIONS FROM THE DIMENSIONS AND CONDITIONS AS SHOWN ON THIS DRAWING. CONTRACTORS SHALL ENSURE THAT ALL CONSTRUCTION WILL COMPLY TO ALL APPLICABLE BUILDING CODES. ROBERT BLANEY DESIGN WILL NOT ACCEPT RESPONSIBILITY FOR VARIATIONS OR MODIFICATION OF THESE PLANS.

Window Schedule ALL FLOORS					
Level	Mark	Sill Height	Width	Height	Area
MAIN FLOOR	W2	2'	7'	7'	49 ft ²
MAIN FLOOR	W3	1'	3.5'	7'	25 ft ²
MAIN FLOOR	W4	3.5'	4.5'	4.5'	20 ft ²
MAIN FLOOR	W5	3'	3'	6'	18 ft ²
2ND FLOOR	W8	3'	6'	6'	36 ft ²
2ND FLOOR	W10	6'	3'	2'	6 ft ²
2ND FLOOR	W11	6'	4'	2'	8 ft ²
2ND FLOOR	W12	1'	2.5'	7'	18 ft ²
2ND FLOOR	W13	1'	7'	7'	49 ft ²
BASEMENT	W14	5'	5'	3'	15 ft ²
BASEMENT	W15	5'	5'	3'	15 ft ²
BASEMENT	W16	3'	7'	6'	42 ft ²
2ND FLOOR	W17	1'	4'	7'	28 ft ²

Door Schedule EXTERIOR				
Level	Mark	Width	Height	Function
MAIN FLOOR	4	3.5'	9'	Exterior
MAIN FLOOR	5	5'	8'	Exterior
MAIN FLOOR	7	5'	8'	Exterior
2ND FLOOR	10	3'	8'	Exterior
BASEMENT	19	3'	8'	Exterior
GARAGE SLAB	25	8'	8'	Exterior
GARAGE SLAB	26	3'	8'	Exterior

LEGEND	
STUCCO (WHITE)	A
BRICK (WHITE)	B
WOOD (DARK STAIN)	C
WOOD (WHITE)	D
STANDING SEAM METAL (CHARCOAL)	E
STONE (TBD)	F

SPATIAL SEPERATION - WEST	
AREA OF EXTERIOR WALL	1620.8sf (150.57m ²)
AREA OF OPENINGS	95sf (8.8m ²)
% OF WALL AREA OPENING	5.8%
SETBACK	4' (1.22m)
LIMITING DISTANCE	1.2
MAX ALLOWED OPENING AREA	7%

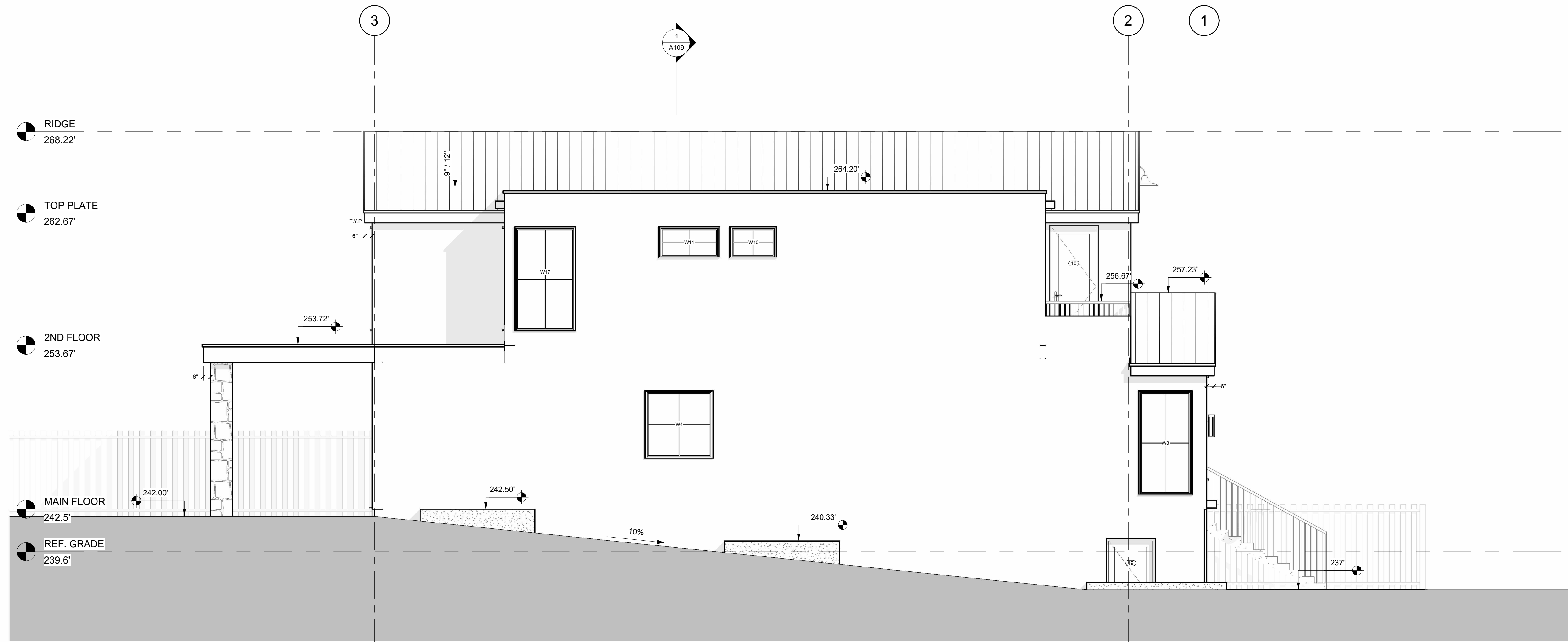

1 WEST
1/4" = 1'-0"



5464 PATRICIA BAY HIGHWAY,
VICTORIA BC V8Y 2N9

(604) 626-6020
ROBERTBLANEYDESIGN@GMAIL.COM
WWW.ROBERTBLANEYDESIGN.COM

REVISIONS
ISSUED FOR: 2023-06-07
REVIEW SET: 8:12:01 AM

PROJECT:
LOT A
332 W 16TH ST.
NORTH VANCOUVER

DRAWING TITLE:
ELEVATIONS - WEST

SHEET:
A107

DRAWN BY:
jp

24X36 SCALE: 1/4" = 1'-0"
PROJECT NUMBER: 038721

START DATE: 05.22.23

COPYRIGHT RESERVED.
THIS DRAWING AND DESIGN ARE AND SHALL AT ALL TIMES REMAIN THE EXCLUSIVE PROPERTY OF ROBERT BLANEY DESIGN AND CANNOT BE USED OR REPRODUCED WITHOUT WRITTEN CONSENT. WRITTEN DIMENSIONS SHALL HAVE PRECEDENCE OVER SCALED DIMENSIONS. CONTRACTOR SHALL VERIFY AND SHALL BE RESPONSIBLE FOR ALL DIMENSIONS AND CONDITIONS ON THE JOB AND THIS OFFICE SHALL BE INFORMED OF ANY VARIATIONS FROM THE DIMENSIONS AND CONDITIONS AS SHOWN ON THIS DRAWING. CONTRACTORS SHALL ENSURE THAT ALL CONSTRUCTION WILL COMPLY TO ALL APPLICABLE BUILDING CODES. ROBERT BLANEY DESIGN WILL NOT ACCEPT RESPONSIBILITY FOR VARIATIONS OR MODIFICATION OF THESE PLANS.

Window Schedule ALL FLOORS					
Level	Mark	Sill Height	Width	Height	Area
MAIN FLOOR	W2	2'	7'	7'	49 ft ²
MAIN FLOOR	W3	1'	3.5'	7'	25 ft ²
MAIN FLOOR	W4	3.5'	4.5'	4.5'	20 ft ²
MAIN FLOOR	W5	3'	3'	6'	18 ft ²
2ND FLOOR	W8	3'	6'	6'	36 ft ²
2ND FLOOR	W10	6'	3'	2'	6 ft ²
2ND FLOOR	W11	6'	4'	2'	8 ft ²
2ND FLOOR	W12	1'	2.5'	7'	18 ft ²
2ND FLOOR	W13	1'	7'	7'	49 ft ²
BASEMENT	W14	5'	5'	3'	15 ft ²
BASEMENT	W15	5'	5'	3'	15 ft ²
BASEMENT	W16	3'	7'	6'	42 ft ²
2ND FLOOR	W17	1'	4'	7'	28 ft ²

Door Schedule EXTERIOR				
Level	Mark	Width	Height	Function
MAIN FLOOR	4	3.5'	9'	Exterior
MAIN FLOOR	5	5'	8'	Exterior
MAIN FLOOR	7	5'	8'	Exterior
2ND FLOOR	10	3'	8'	Exterior
BASEMENT	19	3'	8'	Exterior
GARAGE SLAB	25	8'	8'	Exterior
GARAGE SLAB	26	3'	8'	Exterior

LEGEND	
STUCCO (WHITE)	A
BRICK (WHITE)	B
WOOD (DARK STAIN)	C
WOOD (WHITE)	D
STANDING SEAM METAL (CHARCOAL)	E
STONE (TBD)	F

SPATIAL SEPERATION - WEST	
AREA OF EXTERIOR WALL	1460.3sf (135.66m ²)
AREA OF OPENINGS	18sf (1.7m ²)
% OF WALL AREA OPENING	3.9%
SETBACK	4' (1.22m)
LIMITING DISTANCE	1.2
MAX ALLOWED OPENING AREA	7%

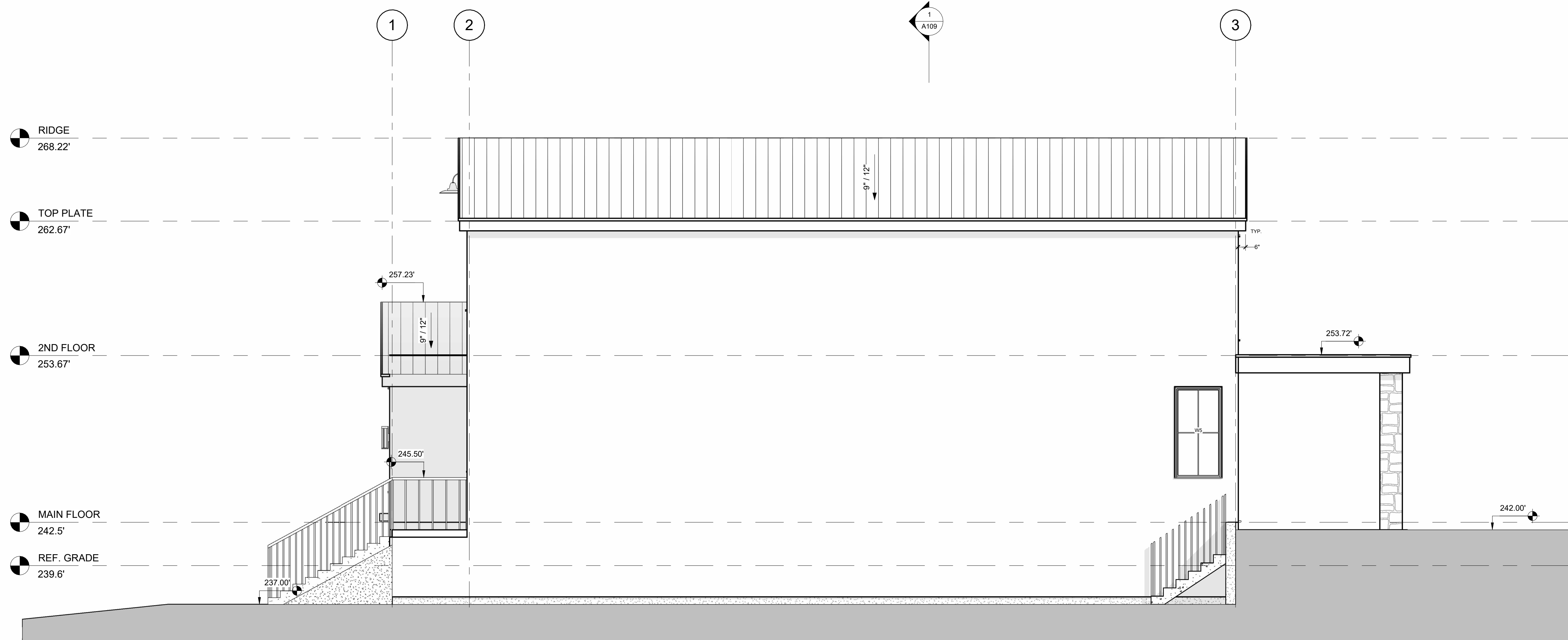

1 EAST
1/4" = 1'-0"

ROBERT BLANEY
HOMES

5464 PATRICIA BAY HIGHWAY,
VICTORIA BC V8Y 2N9

(604) 626-6020
ROBERTBLANEYDESIGN@GMAIL.COM
WWW.ROBERTBLANEYDESIGN.COM

REVISIONS
ISSUED FOR: 2023-06-07 8:12:06 AM
REVIEW SET:

PROJECT:
LOT A
332 W 16TH ST.
NORTH VANCOUVER

SHEET:

A108

DRAWN BY:
jp

24X36 SCALE:
1/4" = 1'-0"

START DATE:
05.22.23

PROJECT NUMBER:
038721

COPYRIGHT RESERVED.

THIS DRAWING AND DESIGN ARE AND SHALL AT ALL TIMES REMAIN THE EXCLUSIVE PROPERTY OF ROBERT BLANEY DESIGN AND CANNOT BE USED OR REPRODUCED WITHOUT WRITTEN CONSENT. WRITTEN DIMENSIONS SHALL HAVE PRECEDENCE OVER SCALED DIMENSIONS. CONTRACTOR SHALL VERIFY AND SHALL BE RESPONSIBLE FOR ALL DIMENSIONS AND CONDITIONS ON THE JOB AND THIS OFFICE SHALL BE INFORMED OF ANY VARIATIONS FROM THE DIMENSIONS AND CONDITIONS AS SHOWN ON THIS DRAWING. CONTRACTORS SHALL ENSURE THAT ALL CONSTRUCTION WILL COMPLY TO ALL APPLICABLE BUILDING CODES. ROBERT BLANEY DESIGN WILL NOT ACCEPT RESPONSIBILITY FOR VARIATIONS OR MODIFICATION OF THESE PLANS.

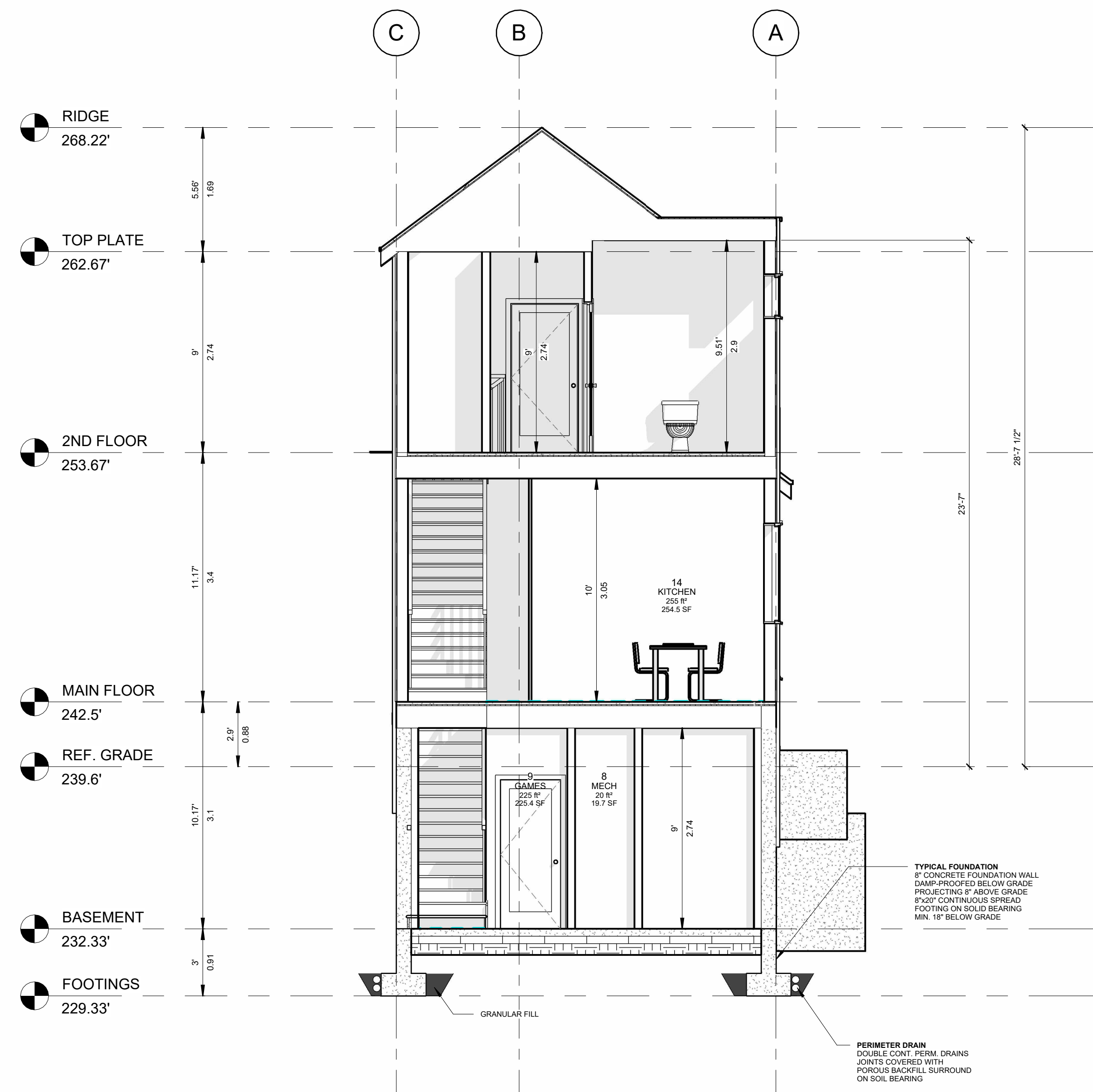

W1 EXTERIOR WALL (ABOVE GRADE)
 CLADDING
 1/2" PURLINS OR RAIN-SCREEN SYSTEM
 TYVEK SEALED & TAPED
 1/2" PLYWOOD SHEATHING
 2X6" STUDS @ 16" O.C
 BATT INSULATION (R22)
 6MIL POLY V.B
 1/2" G.W.B PAINTED
 AIR FILM (INTERIOR)

W2 FURRED FOUNDATION WALL
 DRAINAGE MAT W/ FILTER FABRIC
 2 COATS OF BITUMINOUS SEALANT
 8" FOUNDATION WALL
 2X4" STUDS @ 16" O.C
 BATT INSULATION (R22)
 6MIL POLY V.B.
 1/2" G.W.B
 AIR FILM (INTERIOR)

W3 FOUNDATION WALL
 DRAINAGE MAT W/ FILTER FABRIC
 2 COATS OF BITUMINOUS SEALANT
 8" CONCRETE WALL

W4 INTERIOR WALL - 2x6"
 1/2" G.W.B BOTH SIDES
 2X6" STUDS @ 16" O.C

F1 FLOOR OVER CONDITIONED SPACE
 FLOOR FINISH
 1-1/2" CONCRETE TOPPING
 3/4" T&G FLOOR SHEATHING GLUED & SCREWED
 11-7/8" TJI JOISTS @ 12" O.C
 1/2" G.W.B PAINTED

F2 FLOOR OVER UNCONDITIONED SPACE
 FLOOR FINISH
 1-1/2" CONCRETE TOPPING
 3/4" T&G FLOOR SHEATHING GLUED & SCREWED
 11-7/8" TJI JOISTS @ 16" O.C
 SPRAY FOAM CLOSED CELL INSUL (R28)

F3 BASEMENT SLAB
 FLOOR FINISH
 4" REINFORCED CONCRETE SLAB
 6MIL POLY V.B
 3" RIGID INSULATION UNDER SLAB (R16)
 6" MIN. COMPACTED GRANULAR BASE
 RADON GAS VENTED

F4 PATIO SLAB/DRIVEWAY ON GRADE
 4" REINFORCED CONCRETE SLAB
 6" MIN. COMPACTED GRANULAR BASE

R1 TRUSS ROOF
 STANDING SEAM METAL
 UNDERLAYMENT
 3/4" ROOF SHAETHING
 2X4" CROSS STRAPPING @ 24" O.C
 ENGINEERED TRUSSES @ 24" O.C
 BLOWN INSULATION (R50)
 6MIL POLY V.B. TAPED AND SEALED
 1/2" G.W.B PAINTED
 AIR FILM (INTERIOR)

R2 FLAT ROOF
 2 LAYERS TORCH ON ROOFING
 3/4" ROOF SHAETHING
 2X4" CROSS STRAPPING @ 16" O.C
 16" TGI RAFTERS @ 16" O.C
 BATT INSULATION (R28)
 6MIL POLY V.B. TAPED AND SEALED
 1/2" G.W.B PAINTED
 AIR FILM (INTERIOR)

1 Section 1
 1/4" = 1'-0"

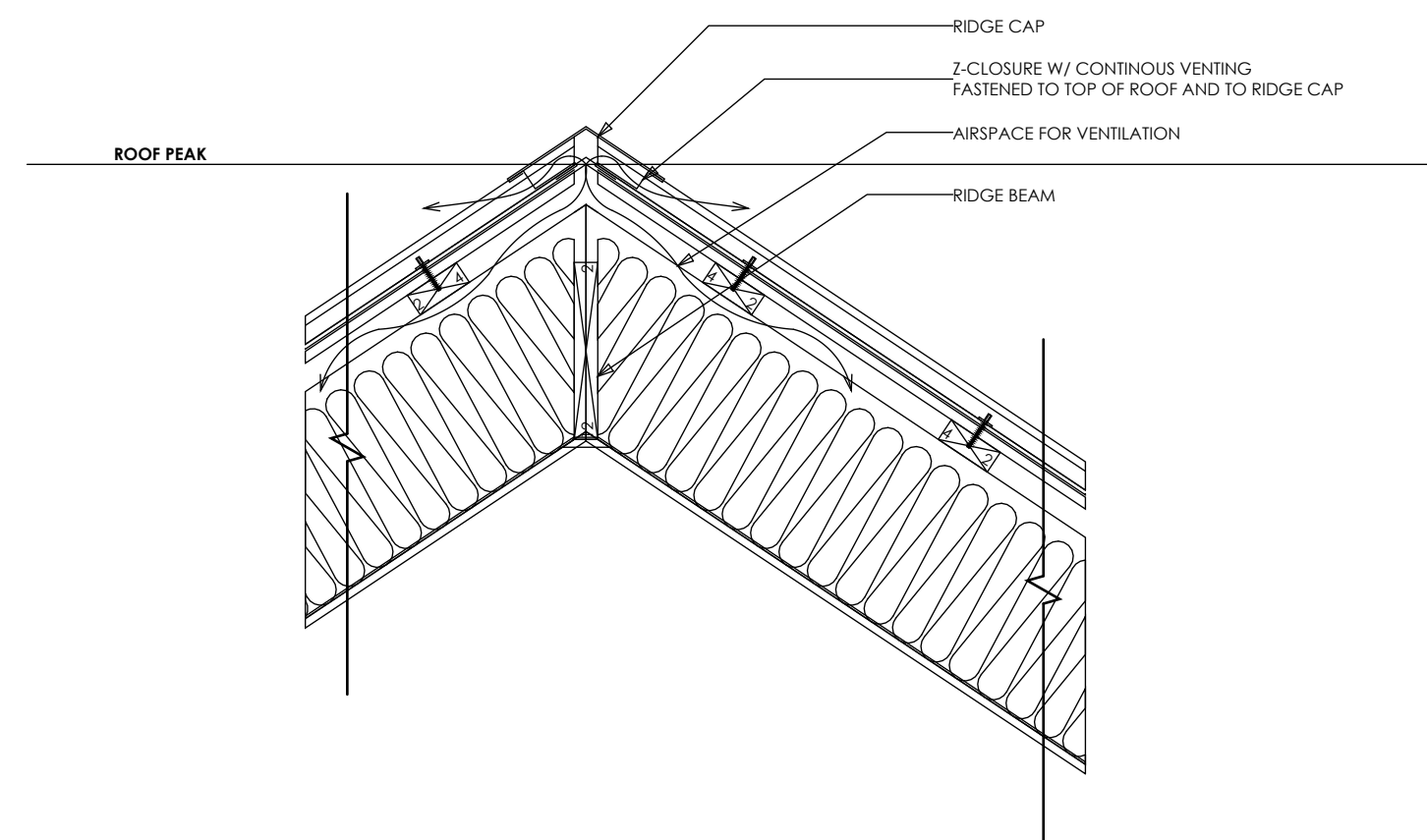

9 RIDGE VENTING - VAULT
1" = 1'-0"

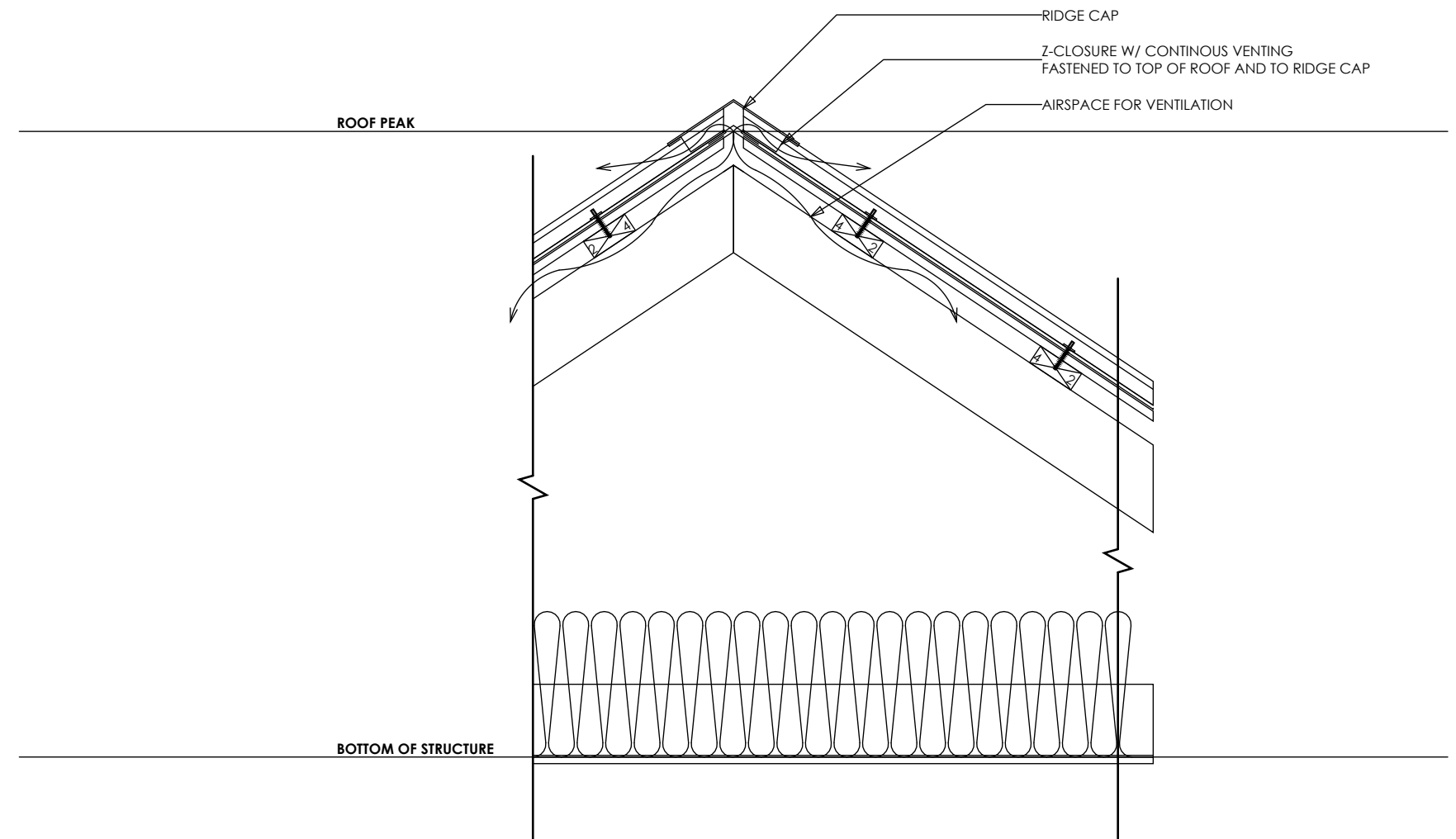

8 RIDGE VENTING - TRUSS
1" = 1'-0"

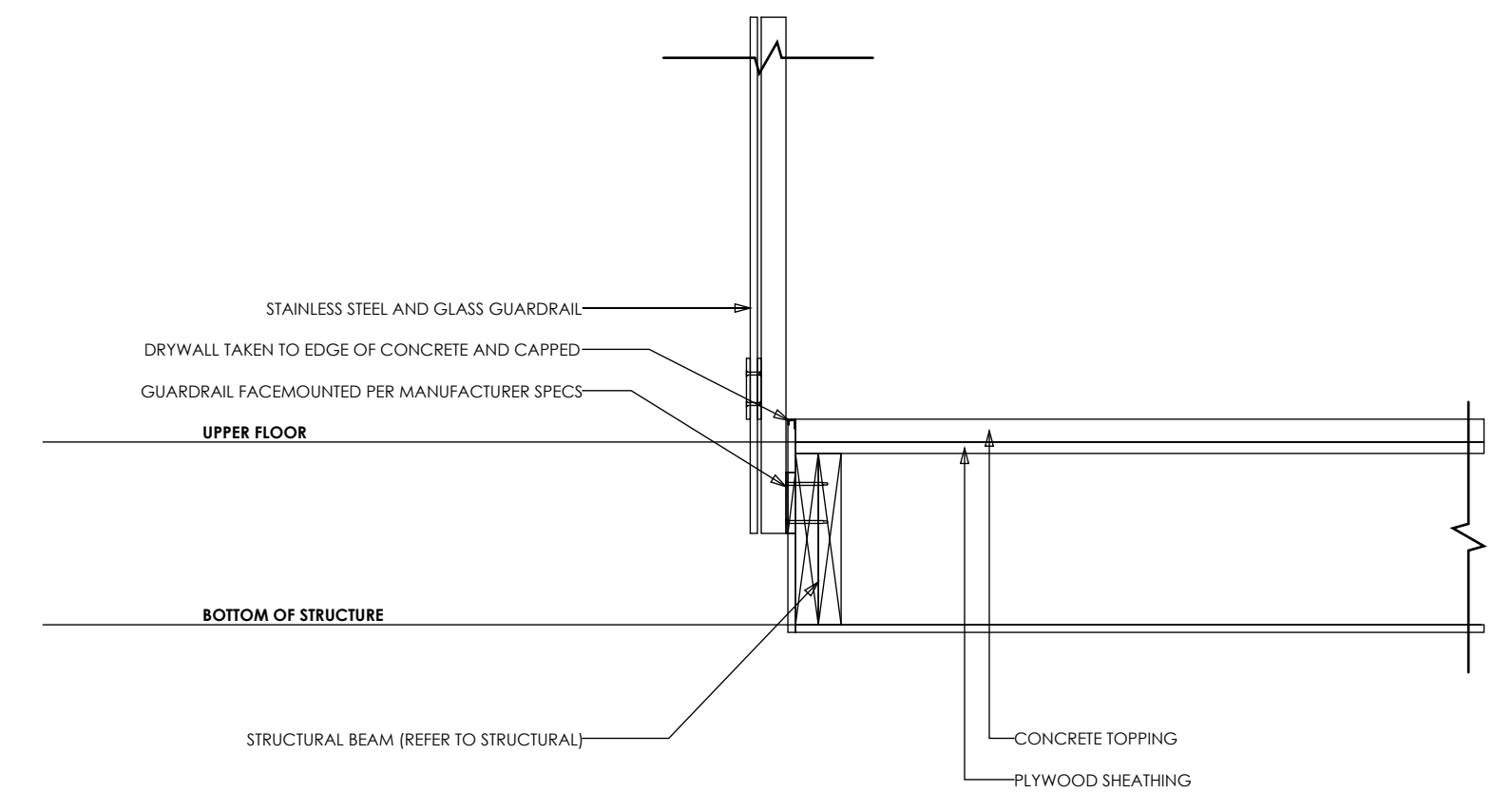

10 GUARDRAIL
1" = 1'-0"

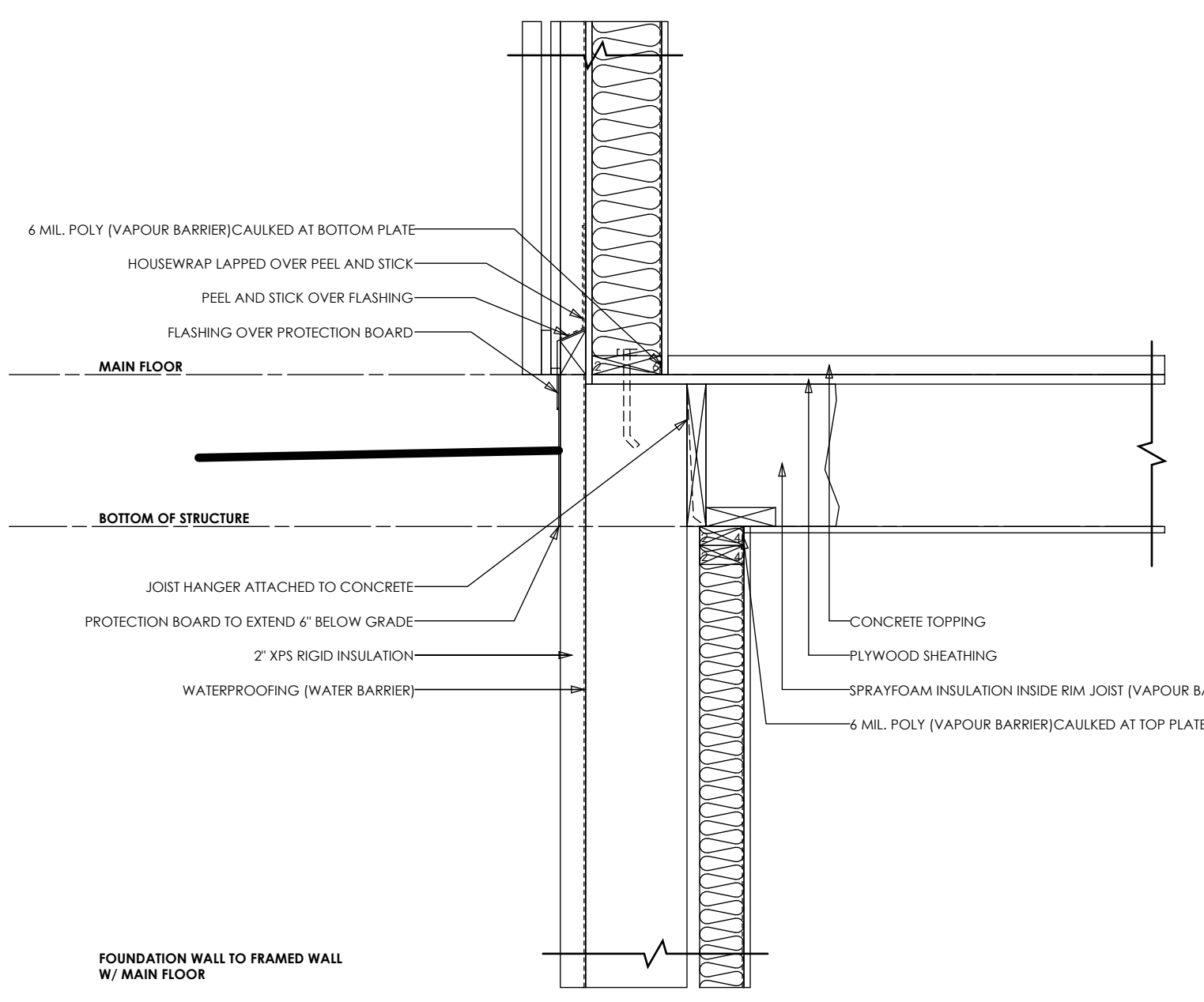

5 FOUNDATION TO MAIN
1" = 1'-0"

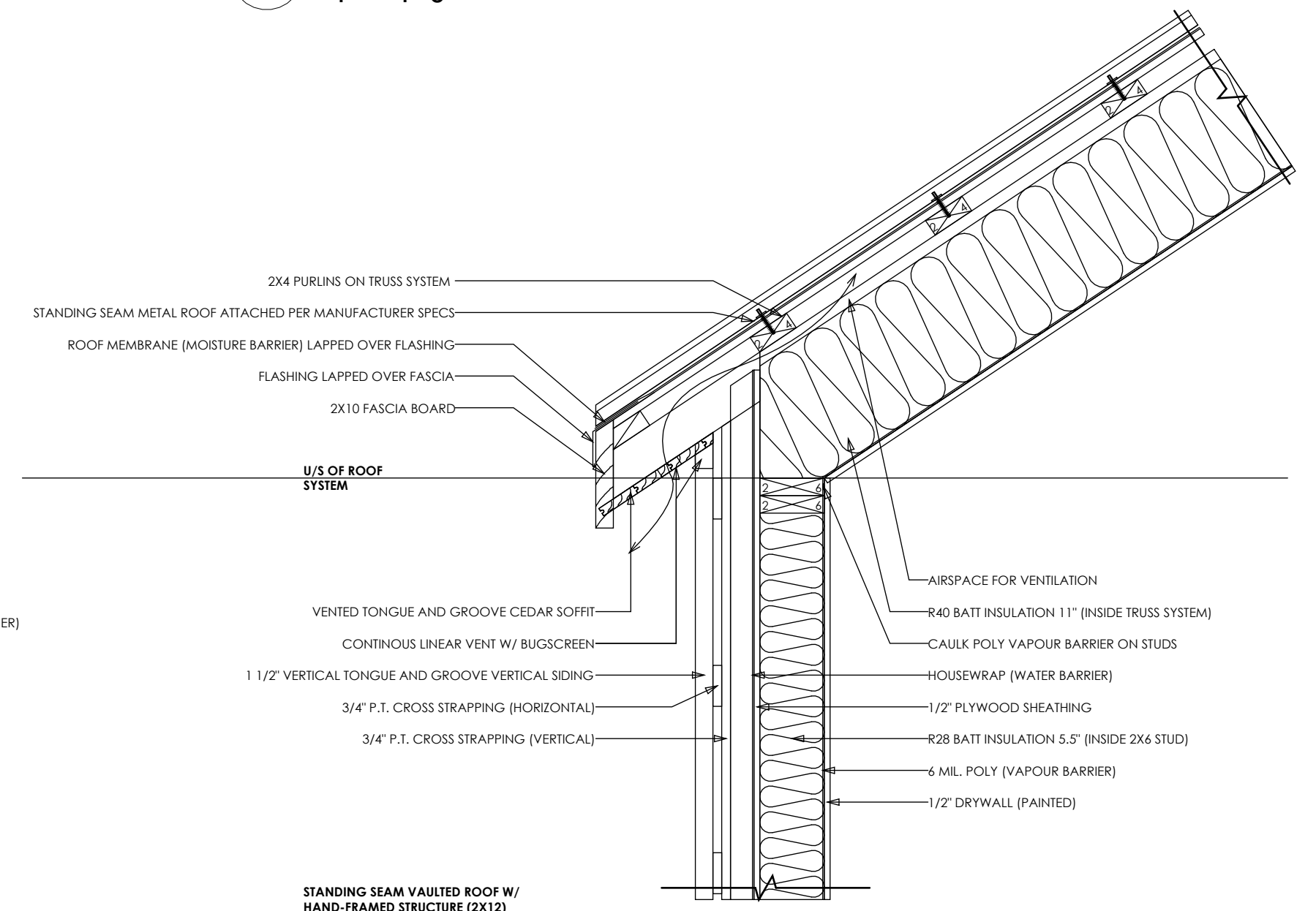

7 2ND TO ROOF
1" = 1'-0"

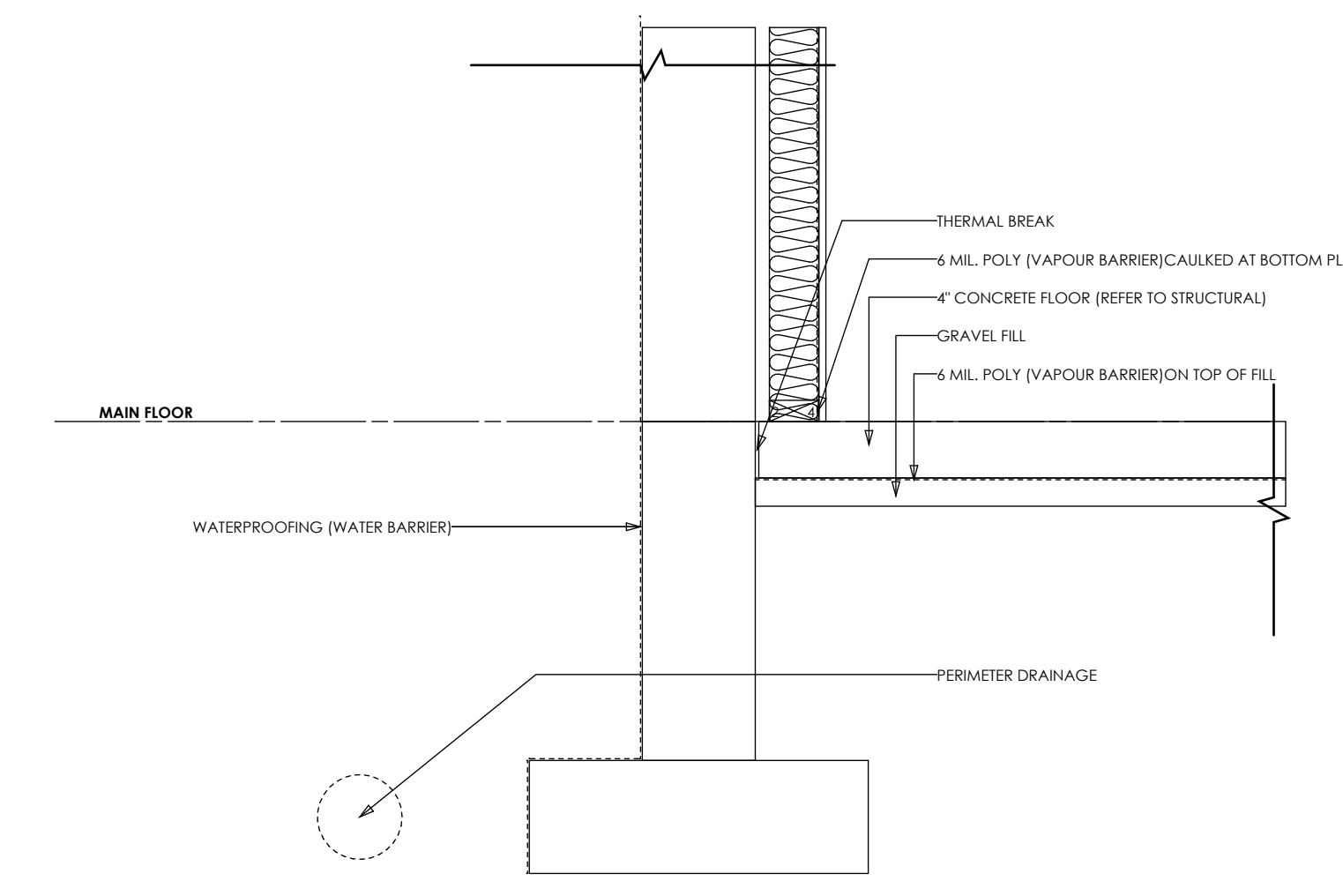

4 FOOTING TO FOUNDATION
1" = 1'-0"

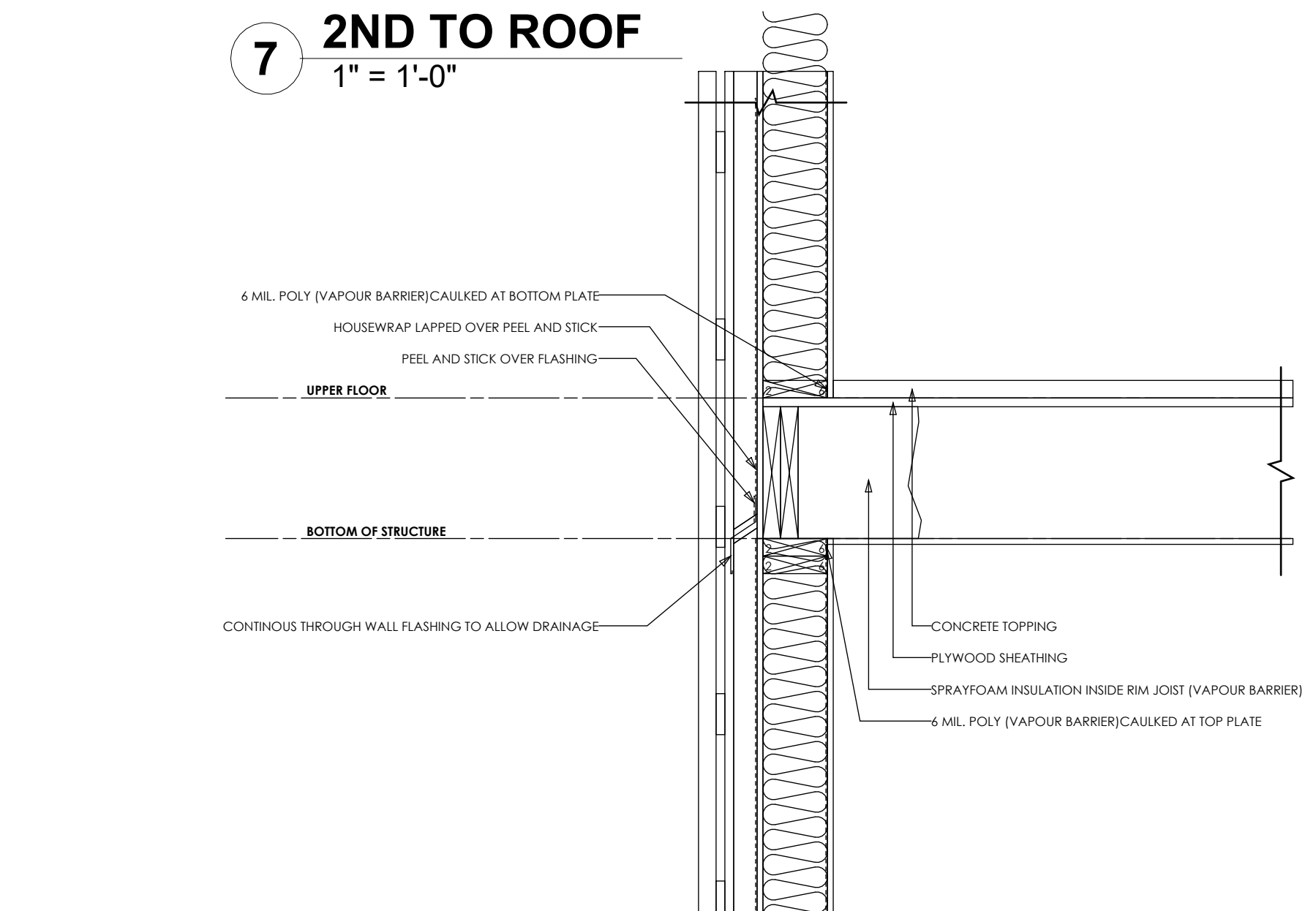

6 MAIN TO 2ND
1" = 1'-0"

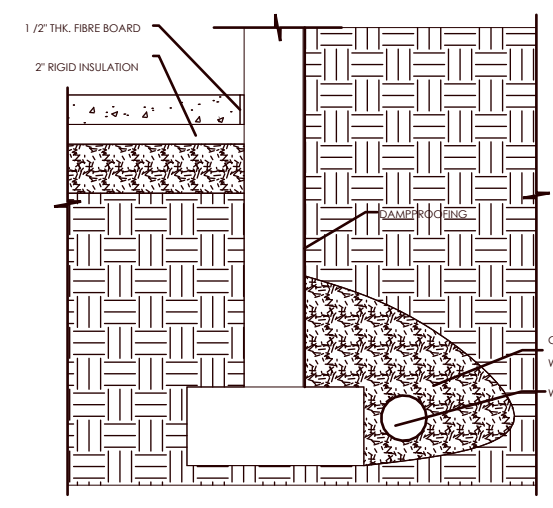

2 FOUNDATION

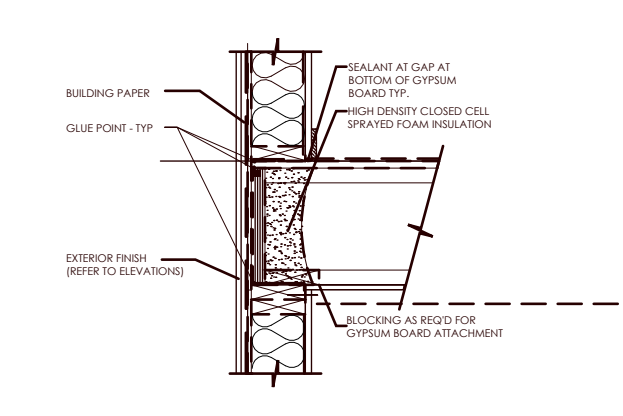

3 FLOOR JOIST

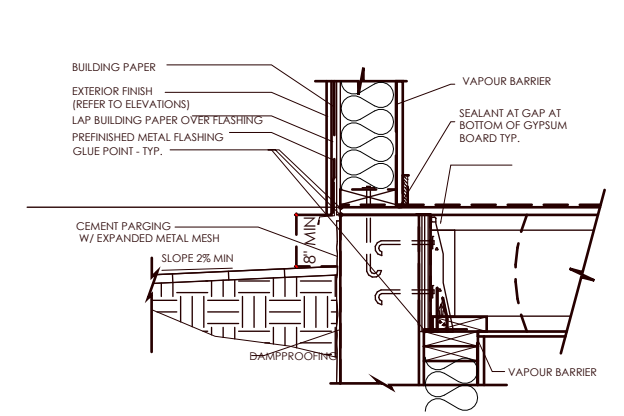

4 FLOOR JOIST

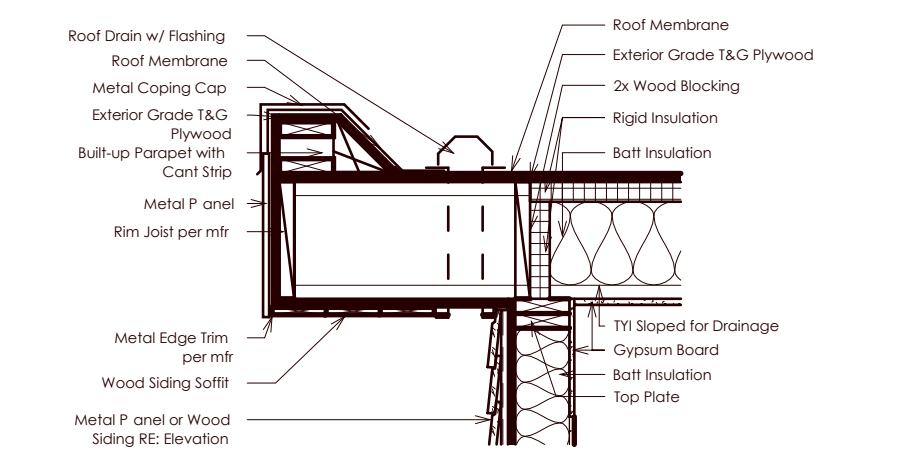

5 FLAT ROOF O.H

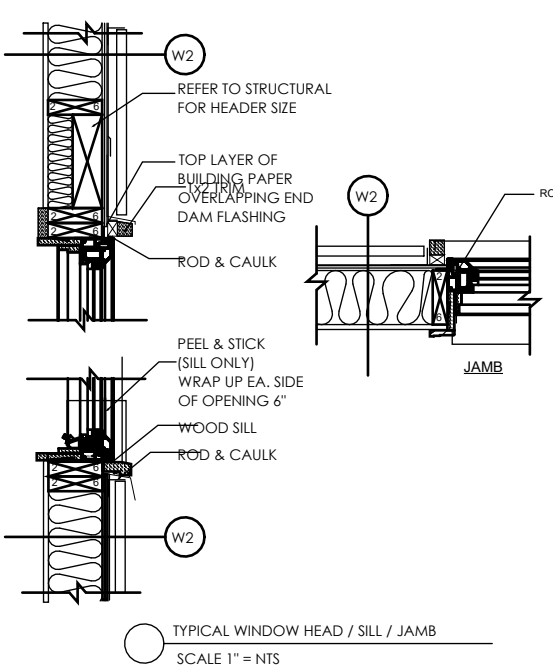

TYPICAL WINDOW HEAD / SILL / JAMB
SCALE 1" = 1/4"

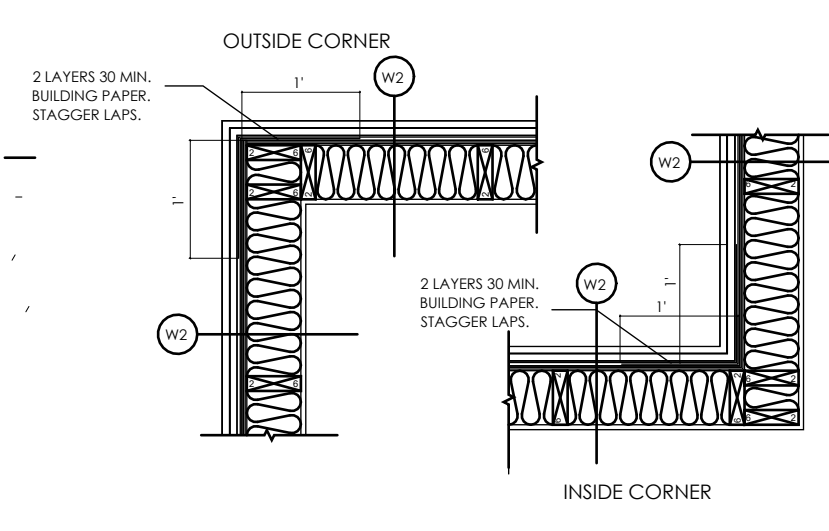

TYPICAL EXTERIOR WALL CONNECTION
SCALE 1" = 1/4"

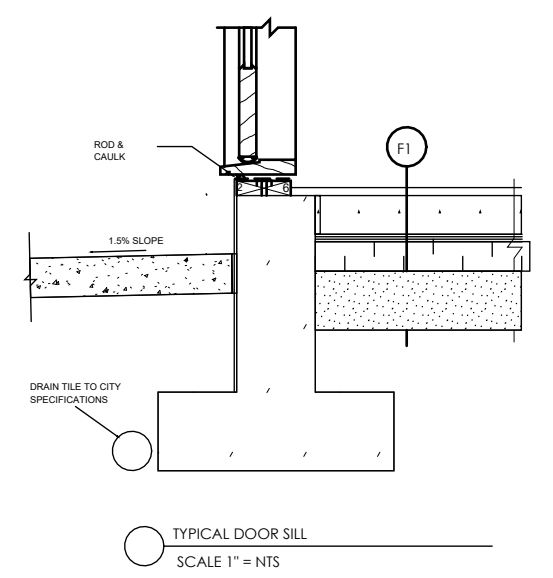

TYPICAL DOOR SILL
SCALE 1" = 1/4"

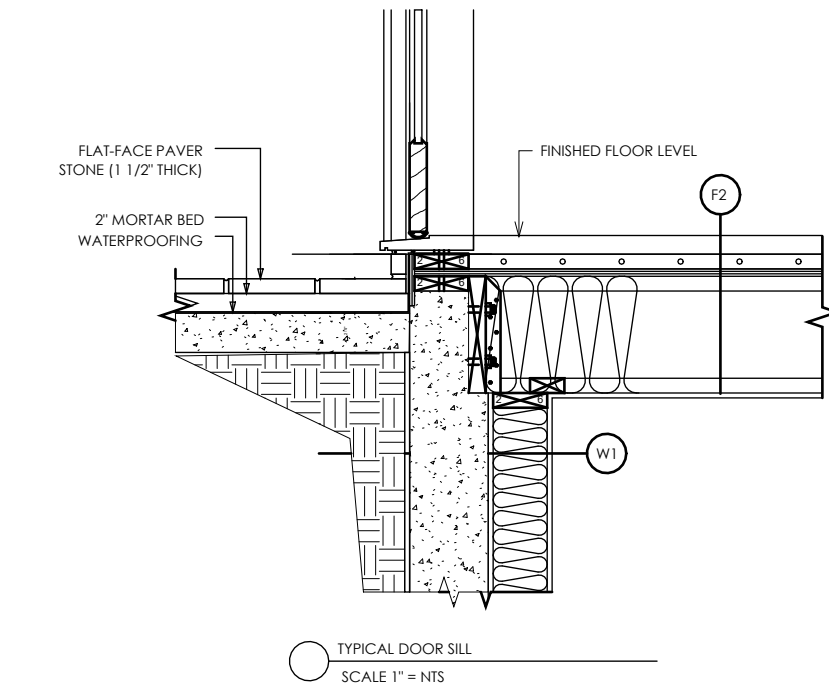

TYPICAL DOOR SILL
SCALE 1" = 1/4"

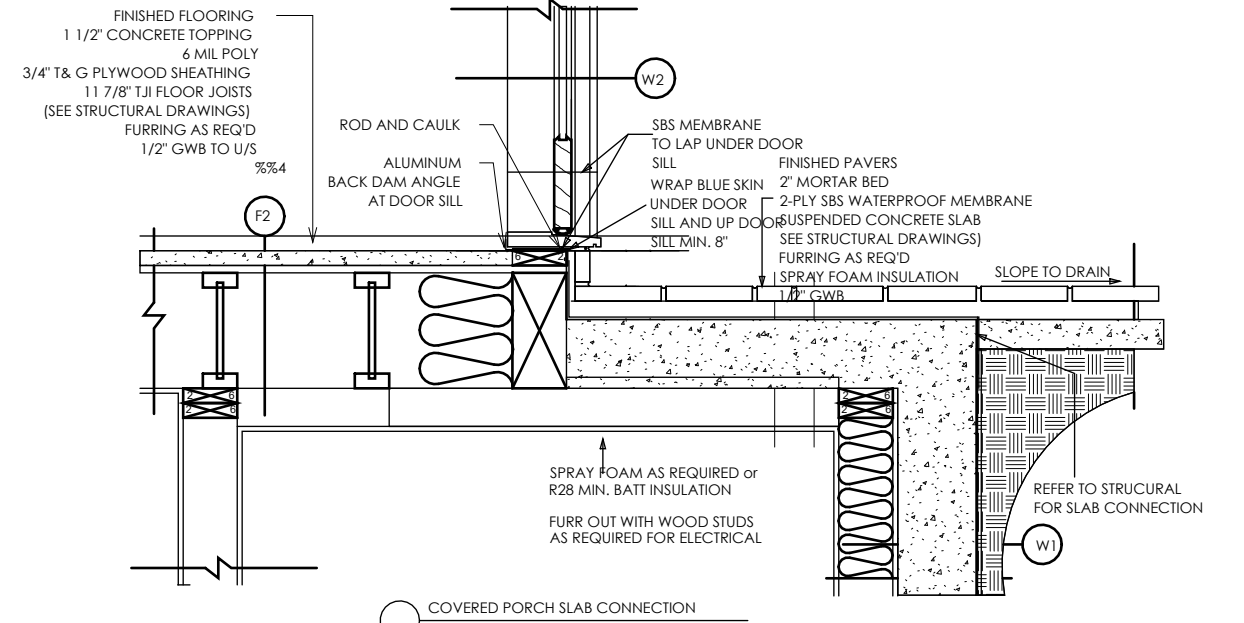

COVERED PORCH SLAB CONNECTION
SCALE 1" = 1/4"

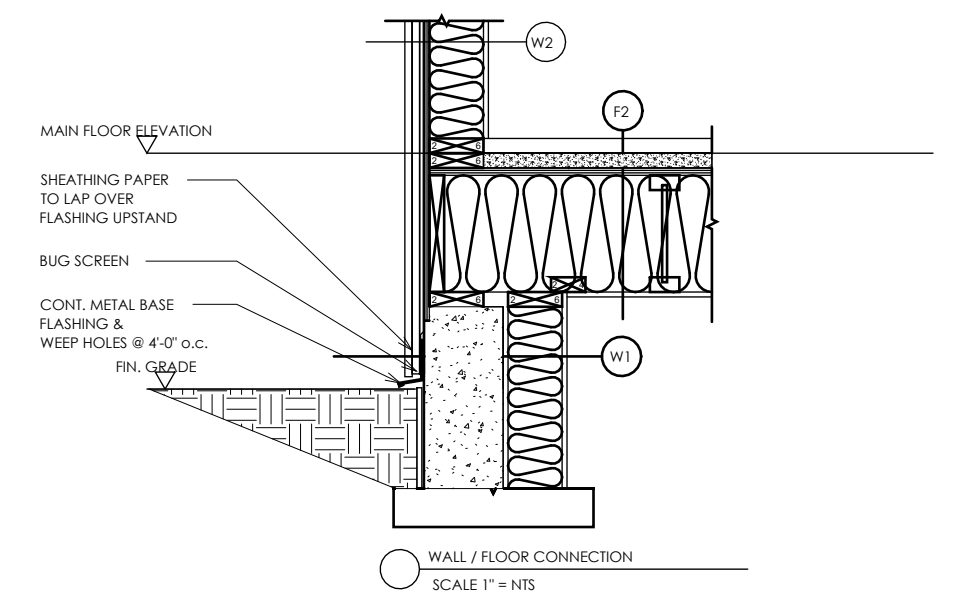

WALL / FLOOR CONNECTION
SCALE 1" = 1/4"

REVISIONS	PROJECT:
ISSUED FOR:	LOT A
REVIEW SET:	332 W 16TH ST.
	NORTH VANCOUVER

2023-06-07	SHEET:
8:12:12 AM	

DRAWN BY:	jp
24X36 SCALE:	As indicated
PROJECT NUMBER:	038721
START DATE:	05.22.23

DRAWING TITLE:	
DETAILS	

COPYRIGHT RESERVED.
THIS DRAWING AND DESIGN ARE AND SHALL AT ALL TIMES REMAIN THE EXCLUSIVE PROPERTY OF ROBERT BLANEY DESIGN AND CANNOT BE USED OR REPRODUCED WITHOUT WRITTEN CONSENT. WRITTEN DIMENSIONS SHALL HAVE PRECEDENCE OVER SCALED DIMENSIONS. CONTRACTOR SHALL VERIFY AND SHALL BE RESPONSIBLE FOR ALL DIMENSIONS AND CONDITIONS ON THE JOB AND THIS OFFICE SHALL BE INFORMED OF ANY VARIATIONS FROM THE DIMENSIONS AND CONDITIONS AS SHOWN ON THIS DRAWING. CONTRACTORS SHALL ENSURE THAT ALL CONSTRUCTION WILL COMPLY TO ALL APPLICABLE BUILDING CODES. ROBERT BLANEY DESIGN WILL NOT ACCEPT RESPONSIBILITY FOR VARIATIONS OR MODIFICATION OF THESE PLANS.



5464 PATRICIA BAY HIGHWAY,
VICTORIA BC V8Y 2N9
(604) 626-6020
ROBERTBLANEYDESIGN@GMAIL.COM
WWW.ROBERTBLANEYDESIGN.COM

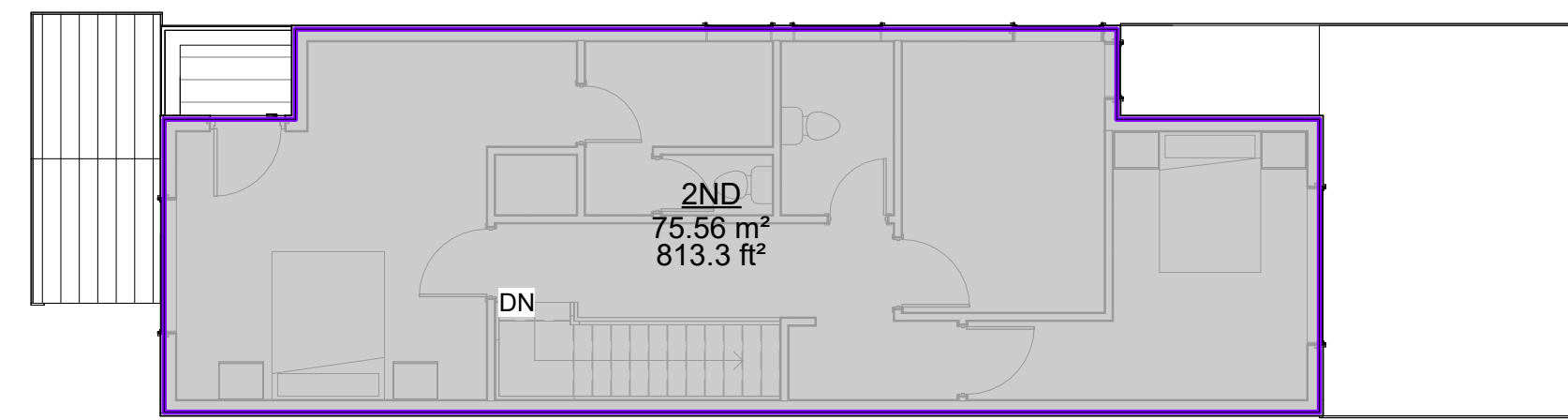

2 2ND FLOOR
1/8" = 1'-0"

Area Schedule (Gross Building)			
Name	Area	Level	Perimeter
MAIN	932 ft²	MAIN FLOOR	147'
2ND	813 ft²	2ND FLOOR	136.67'
BASEMENT	961 ft²	BASEMENT	147'
GARAGE	290 ft²	GARAGE SLAB	72.17'
	2996 ft²		

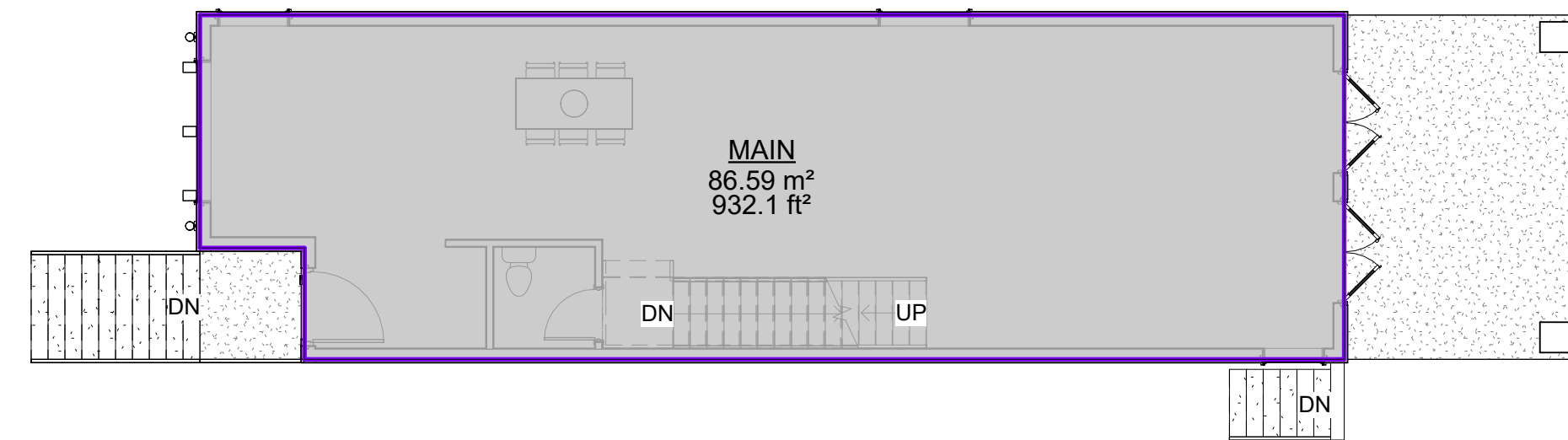

1 MAIN FLOOR
1/8" = 1'-0"

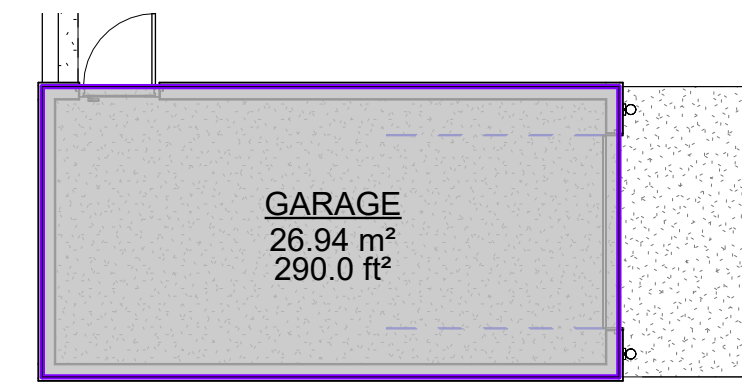

4 GARAGE
1/8" = 1'-0"

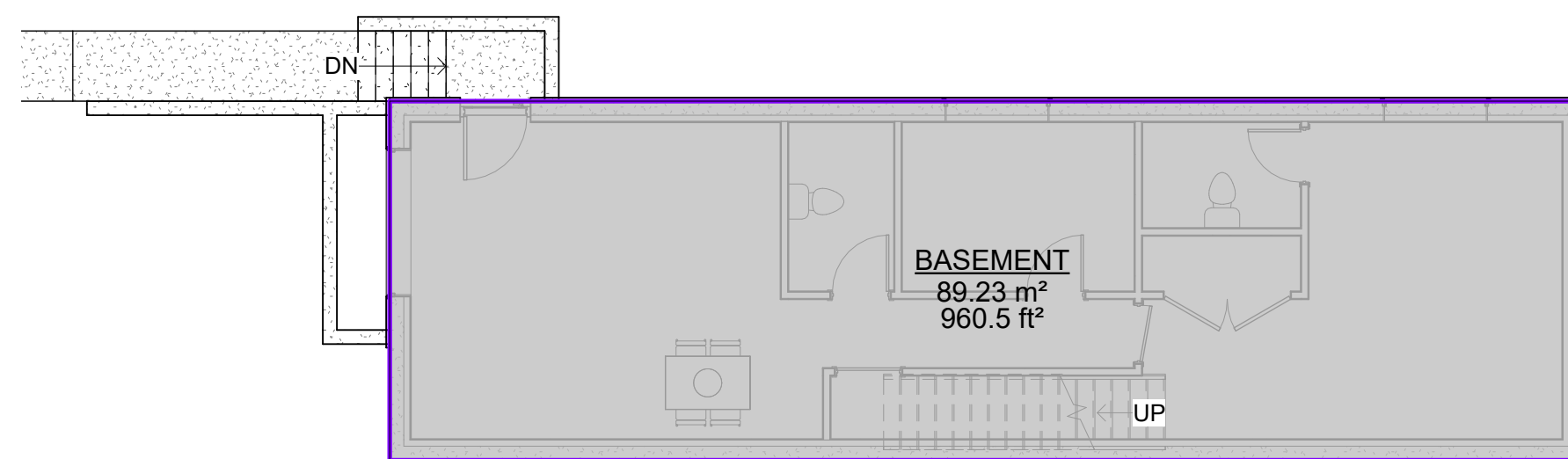

3 BASEMENT
1/8" = 1'-0"

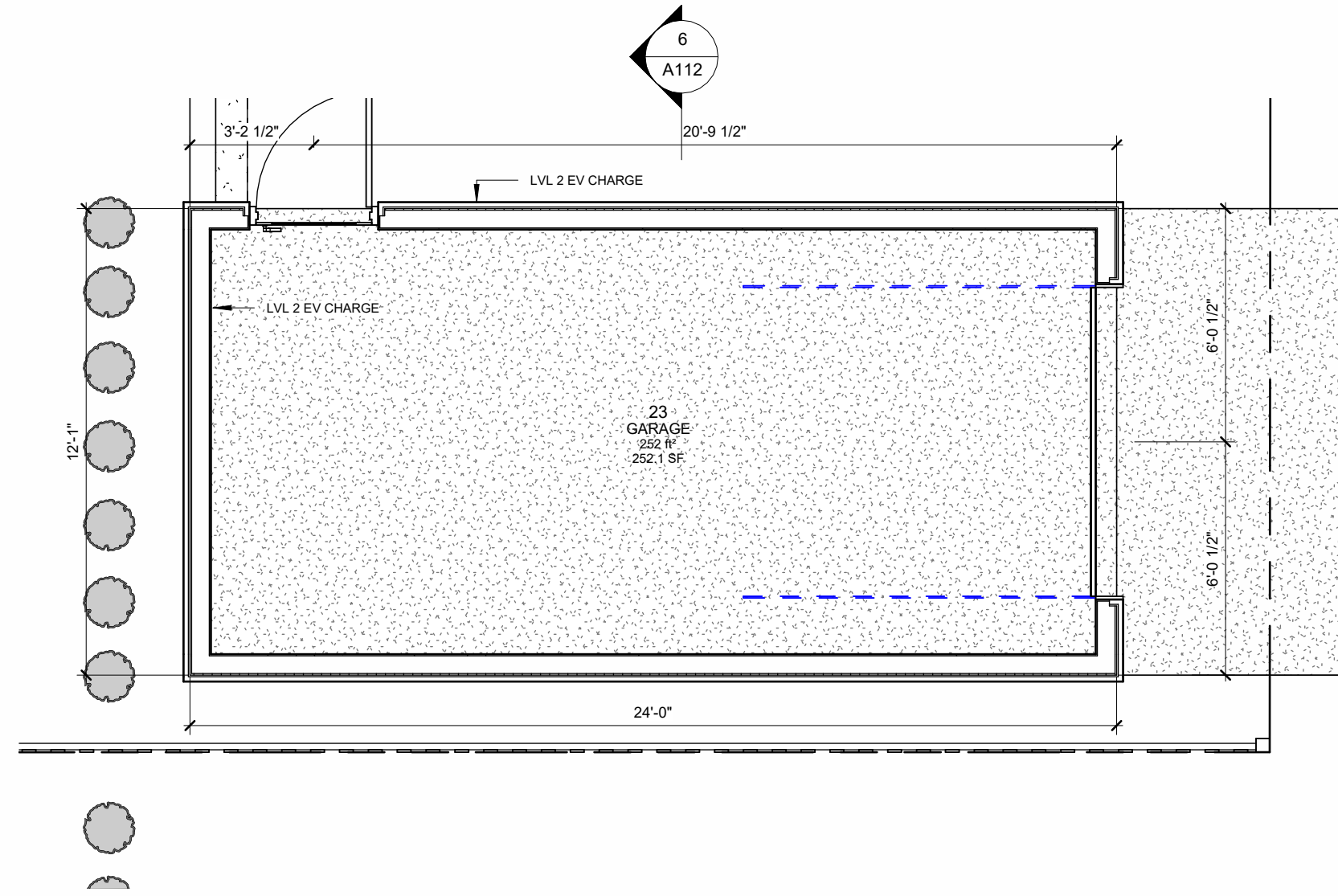

1 GARAGE
1/4" = 1'-0"

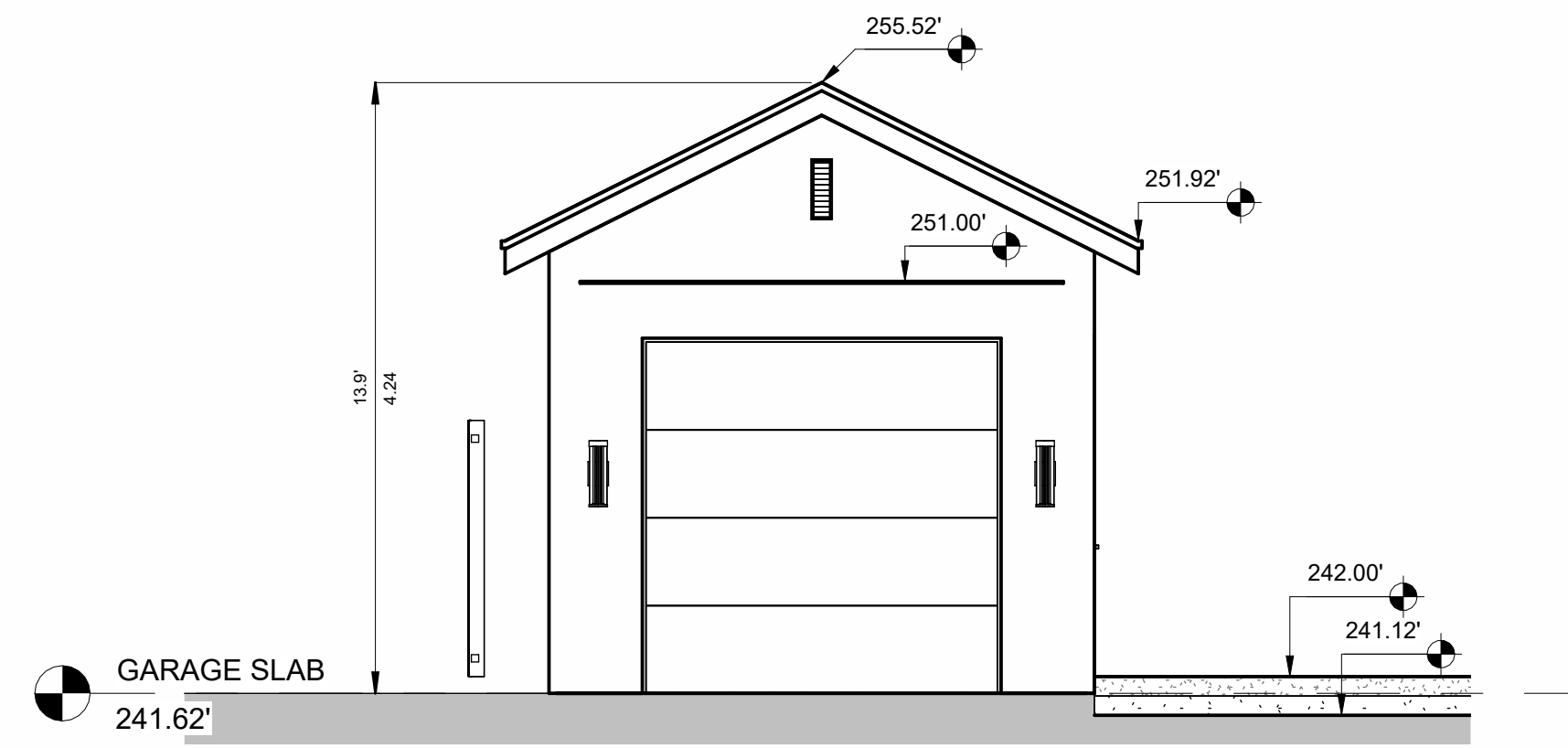

3 GARAGE NORTH
1/4" = 1'-0"

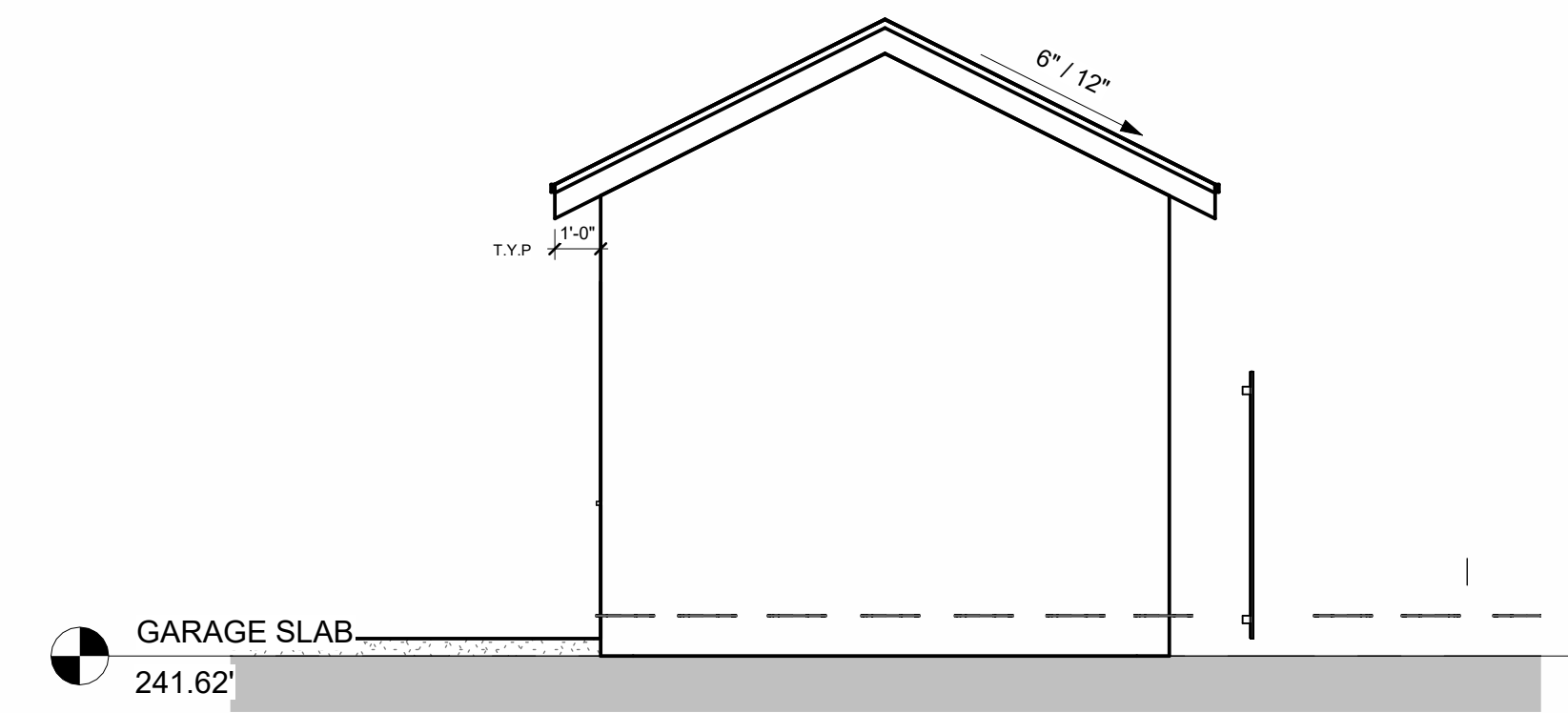

4 GARAGE SOUTH
1/4" = 1'-0"

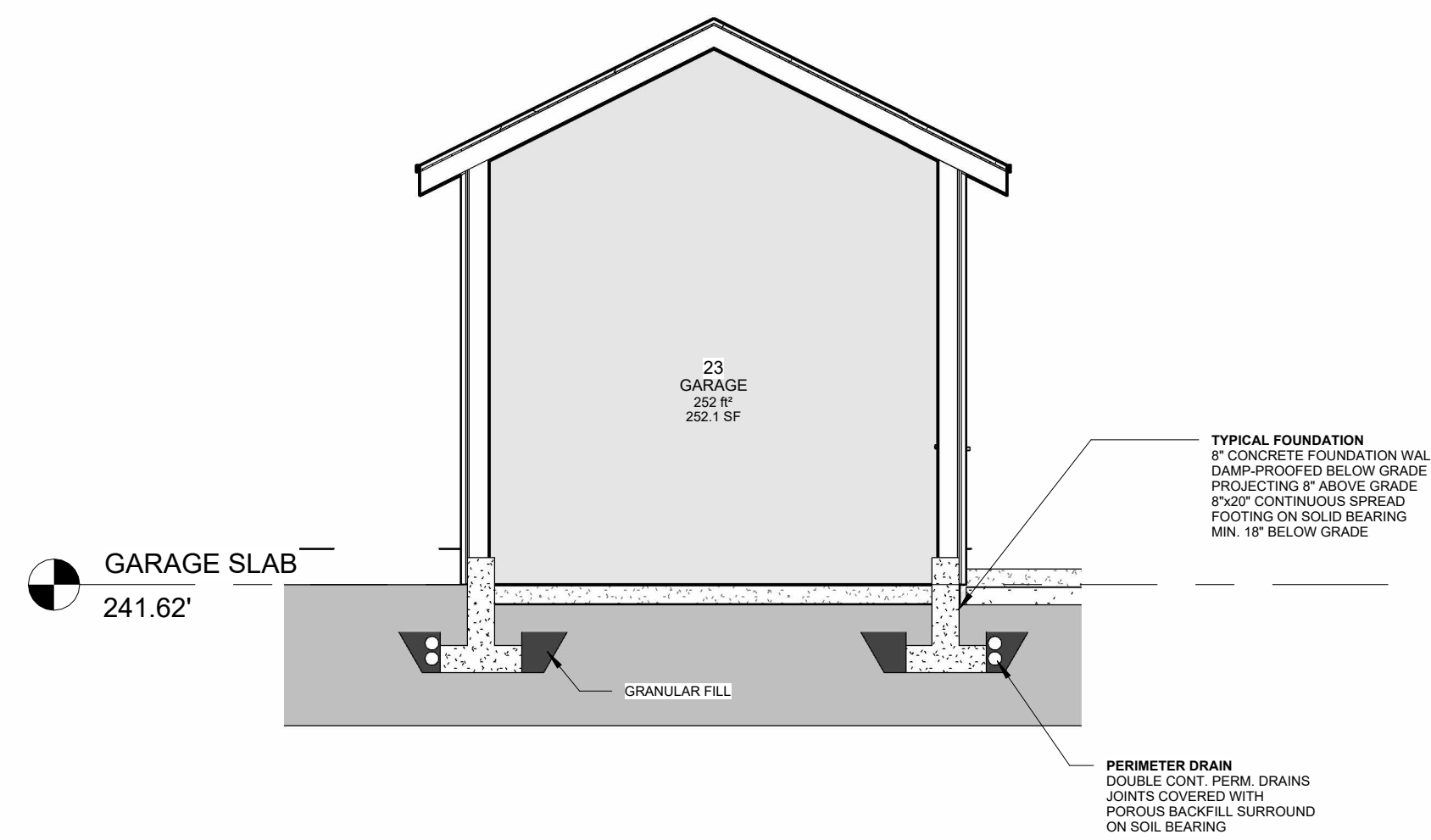

6 GARAGE SECTION
1/4" = 1'-0"

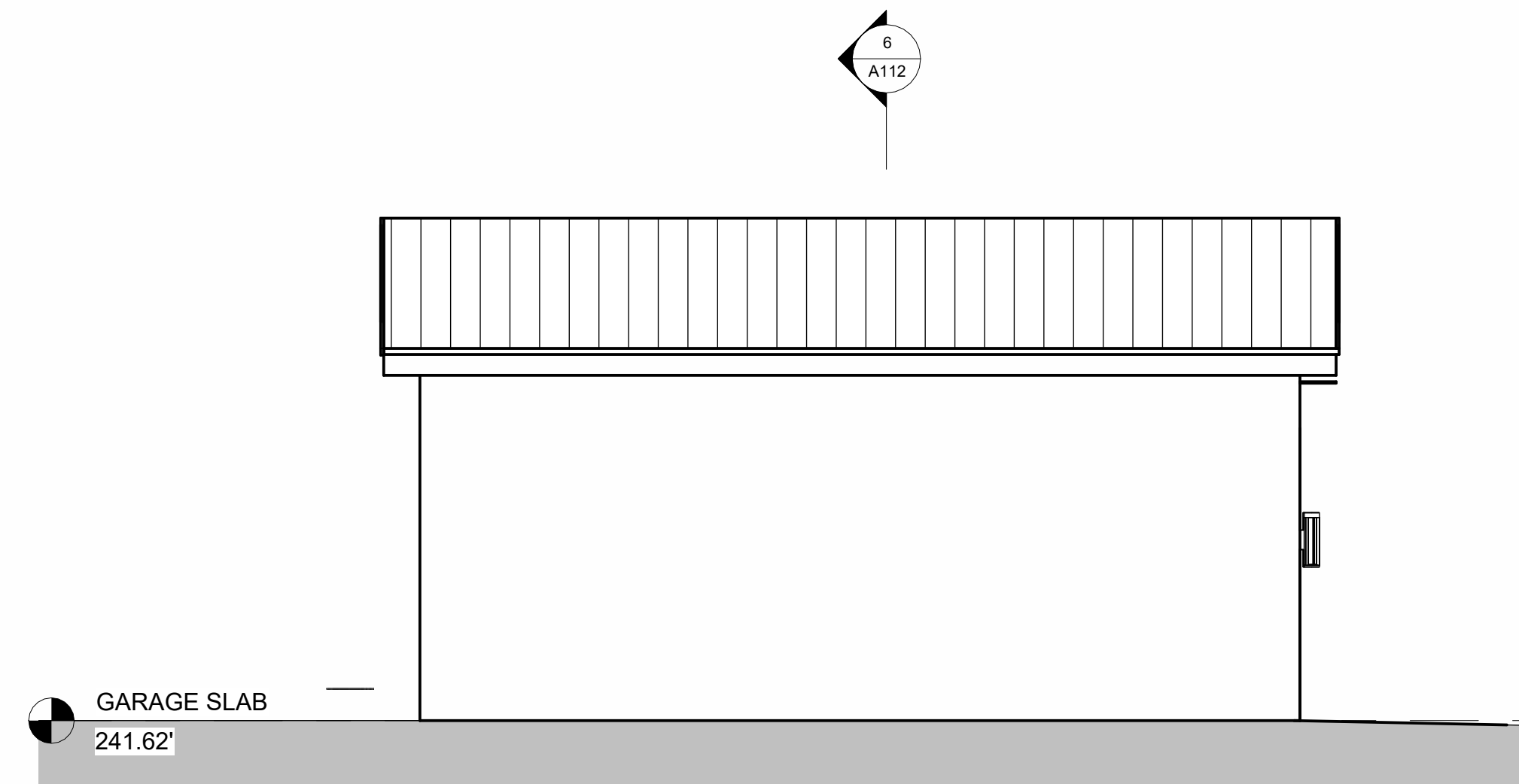

2 GARAGE EAST
1/4" = 1'-0"

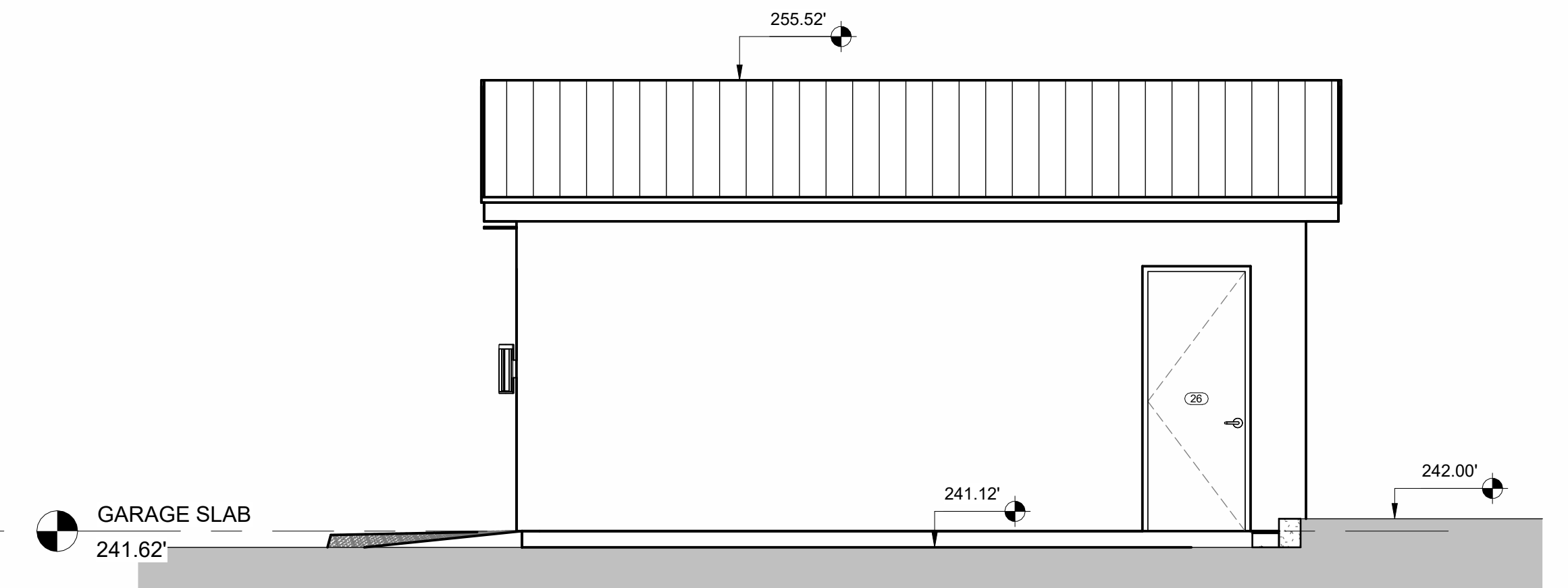

5 GARAGE WEST
1/4" = 1'-0"