



# 528 E 7TH ST. NORTH VANCOUVER

- A100 - SITE PLAN
- A101 - FOUNDATION PLAN
- A102 - BASEMENT FLOOR PLAN
- A103 - MAIN FLOOR PLAN
- A104 - 2ND FLOOR PLAN
- A105 - ROOF PLAN
- A106 - ELEVATIONS - EAST & WEST
- A107 - ELEVATIONS - NORTH & SOUTH
- A108 - SECTIONS & ASSEMBLIES
- A109 - DETAILS
- A110 - F.A.R
- A111 - GARAGE

[WWW.ROBERTBLANEYDESIGN.COM](http://WWW.ROBERTBLANEYDESIGN.COM)

604-626-6020

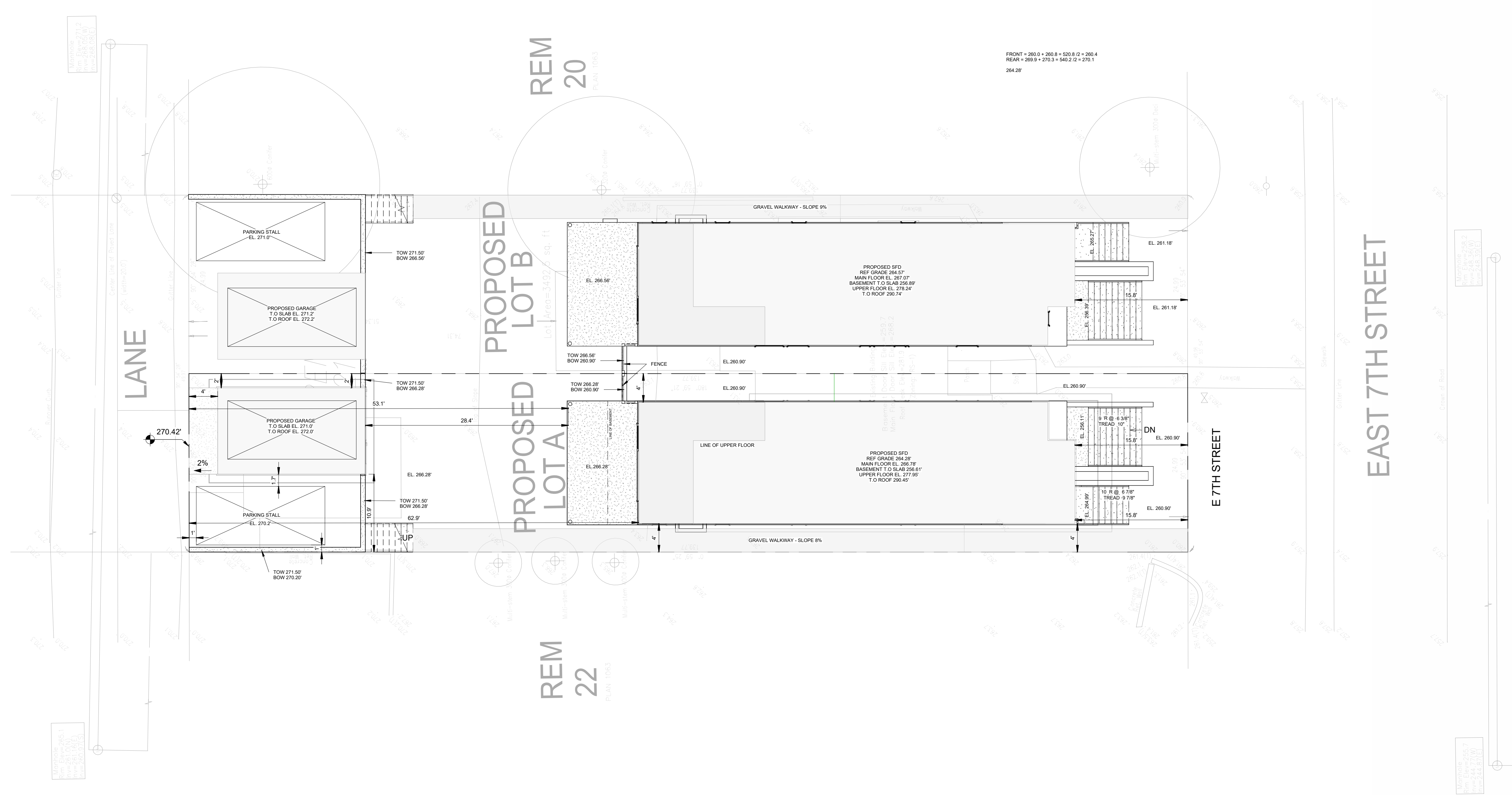
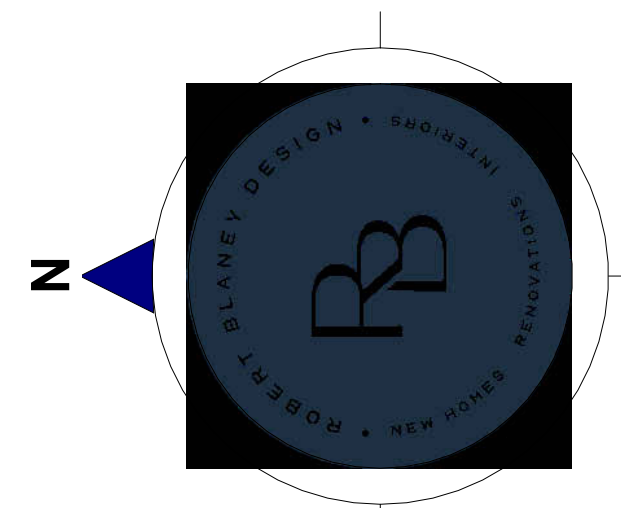

PROJECT STATISTICS				
<b>SITE STATISTICS</b>				
CIVIC ADDRESS:	528 E 7TH ST. NORTH VANCOUVER			
LEGAL DESCRIPTION:	LOT 21, EXCEPT THE NORTH 10 FEET NOW LANE, BLOCK 2 DISTRICT LOT 273 GROUP 1 NWD PLAN 1063			
P.I.D.:	014-888-777			
ZONE:	CNV RS2			
SITE AREA (SQ.FT.):	3,492			
SITE WIDTH (FT):	24.99			
REFERENCE GRADE:	264.28'			
<b>PROJECT STATISTICS</b>				
<b>HOUSE</b>	PERMITTED/REQUIRED		PROPOSED	
	IMPERIAL	METRIC	IMPERIAL	METRIC
TOP PLATE HEIGHT	26.2	7.99	25.17	7.67
BUILDING HEIGHT	33.1	10.09	26.19	7.98
FRONT YARD SETBACK (S)	15	4.57	15.8	4.82
EAST SIDE YARD SETBACK	4	1.22	4	1.22
WEST SIDE YARD SETBACK	4	1.22	4	1.22
REAR YARD SETBACK (N)	26.2	7.99	53.1	16.18
<b>ACCESSORY BUILDING</b>	PERMITTED/REQUIRED		PROPOSED	
	IMPERIAL	METRIC	IMPERIAL	METRIC
BUILDING HEIGHT	12	3.66	0	0.00
FROM PRINCIPAL BUILDING (S)	10	3.05	28.4	8.66
EAST SIDE YARD SETBACK	2	0.61	2	0.61
WEST SIDE YARD SETBACK	2	0.61	10.9	3.32
REAR YARD SETBACK (N)	4	1.22	4	1.22
<b>FLOOR AREAS</b>				
	PERMITTED/REQUIRED		PROPOSED	
	AREA (SF)	AREA (M2)	AREA (SF)	AREA (M2)
FLOOR				
BASEMENT			1075.3	99.90
MAIN FLOOR			908.1	84.36
2ND FLOOR			831.9	
ACCESSORY			249.8	23.21
<b>TOTAL SQ.FT.</b>	1746	162.20	<b>3065.1</b>	<b>284.75</b>
<b>G.F.A. EXEMPTIONS</b>				
	PERMITTED/REQUIRED		PROPOSED	
	AREA (SF)	AREA (M2)	AREA (SF)	AREA (M2)
EXEMPTION				
BASEMENT			1075.3	99.90
ACCESSORY (MAX 600 SF)			249.8	
<b>TOTAL EXEMPT FROM GFA</b>			<b>1325.1</b>	<b>123.10</b>
<b>G.F.A.</b>				
	PERMITTED/REQUIRED		PROPOSED	
	AREA (SF)	AREA (M2)	AREA (SF)	AREA (M2)
TOTAL G.F.A.	SITE AREA x 50% 1746sf (162.2m2)		1740	161.65
<b>SITE COVERAGE - HOUSE</b>				
	PERMITTED/REQUIRED		PROPOSED	
	AREA (SF)	AREA (M2)	AREA (SF)	AREA (M2)
AREA OF HOUSE			908.1	84.36
<b>TOTAL SITE COVERAGE (MAX 30%)</b>	1047.582	97.32	908.1	84.36
<b>SITE COVERAGE - ACCESSORY BUILDINGS &amp; HOUSE</b>				
	PERMITTED/REQUIRED		PROPOSED	
	AREA (SF)	AREA (M2)	AREA (SF)	AREA (M2)
AREA OF ACCESSORY			249.8	23.21
AREA OF HOUSE			908.1	84.36
<b>TOTAL SITE COVERAGE (MAX 40%)</b>	1396.776	129.76	1157.9	107.57

1 SITE  
1/8" = 1'-0"

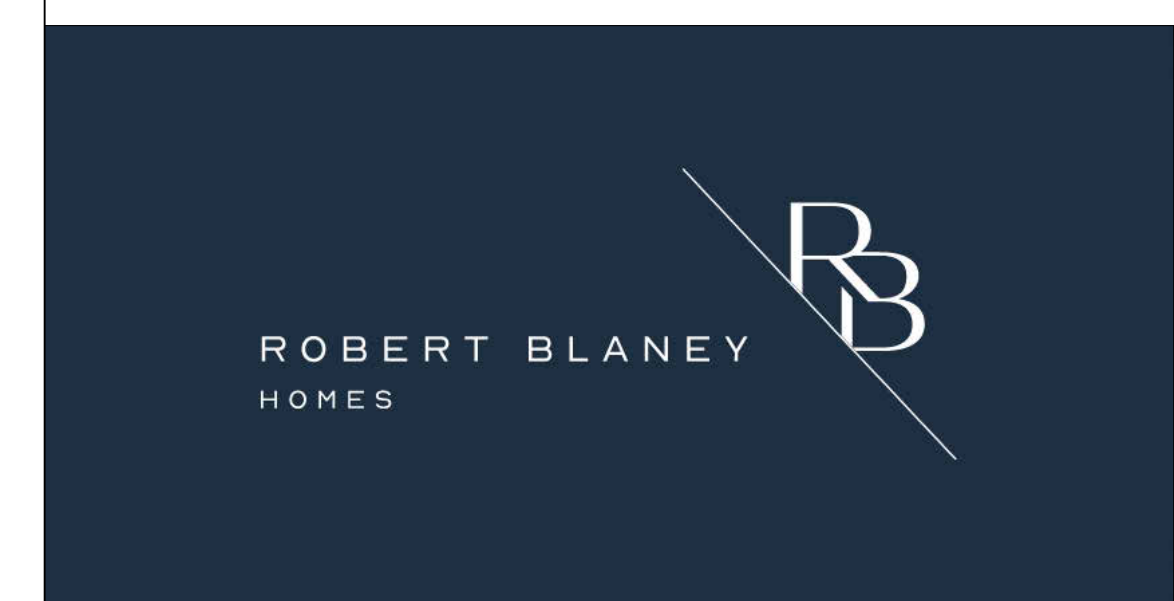

5464 PATRICIA BAY HIGHWAY,  
VICTORIA BC V8Y 2N9  
  
(604) 626-6020  
ROBERTBLANEYDESIGN@GMAIL.COM  
WWW.ROBERTBLANEYDESIGN.COM

REVISIONS  
ISSUED FOR:  
REVIEW SET: 01/23/07

PROJECT:  
NAME LOT A  
ADDRESS 528 EAST 7TH STR  
CITY NORTH VANCOUVER  
  
DRAWING TITLE:  
SITE PLAN

SHEET:  
  
**A100**

DRAWN BY: SDP  
  
24X36 SCALE: 1/8" = 1'-0"  
PROJECT NUMBER: Project Number  
START DATE:

COPYRIGHT RESERVED.  
THIS DRAWING AND DESIGN ARE AND SHALL AT ALL TIMES REMAIN THE EXCLUSIVE PROPERTY OF ROBERT BLANEY DESIGN AND CANNOT BE USED OR REPRODUCED WITHOUT WRITTEN CONSENT. WRITTEN DIMENSIONS SHALL HAVE PRECEDENCE OVER SCALED DIMENSIONS. CONTRACTOR SHALL VERIFY AND SHALL BE RESPONSIBLE FOR ALL DIMENSIONS AND CONDITIONS ON THE JOB AND THIS OFFICE SHALL BE INFORMED OF ANY VARIATIONS FROM THE DIMENSIONS AND CONDITIONS AS SHOWN ON THIS DRAWING. CONTRACTORS SHALL ENSURE THAT ALL CONSTRUCTION WILL COMPLY TO ALL APPLICABLE BUILDING CODES. ROBERT BLANEY DESIGN WILL NOT ACCEPT RESPONSIBILITY FOR VARIATIONS OR MODIFICATION OF THESE PLANS.

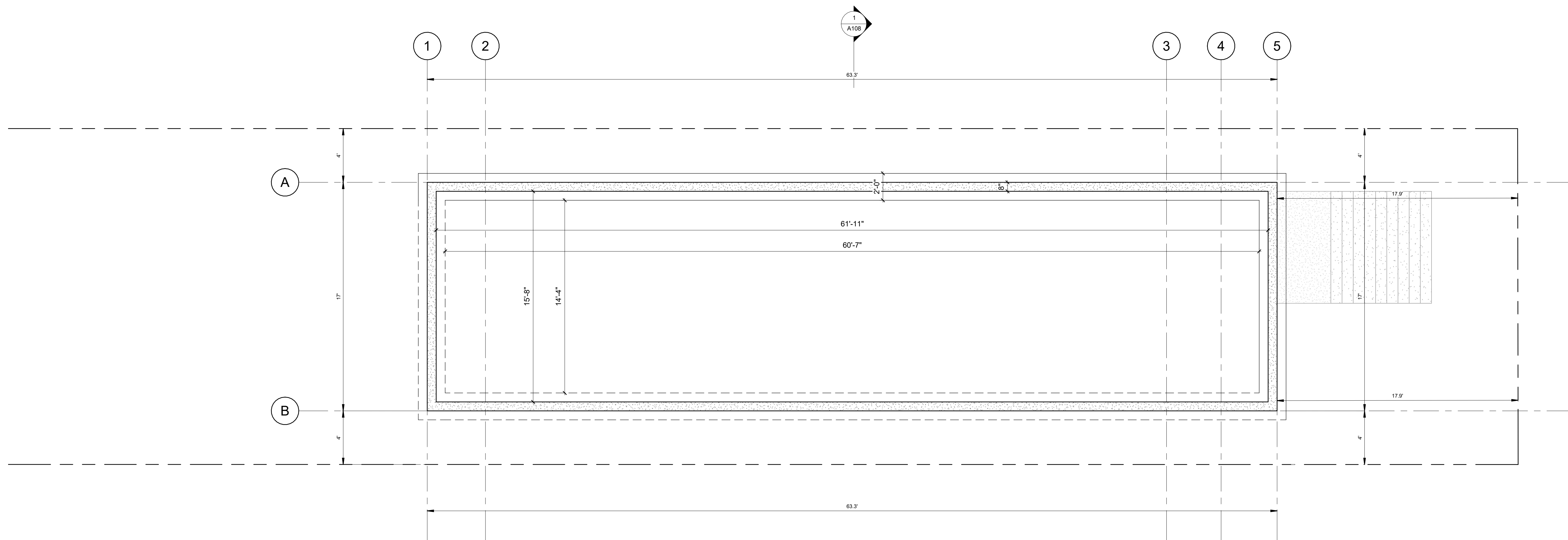
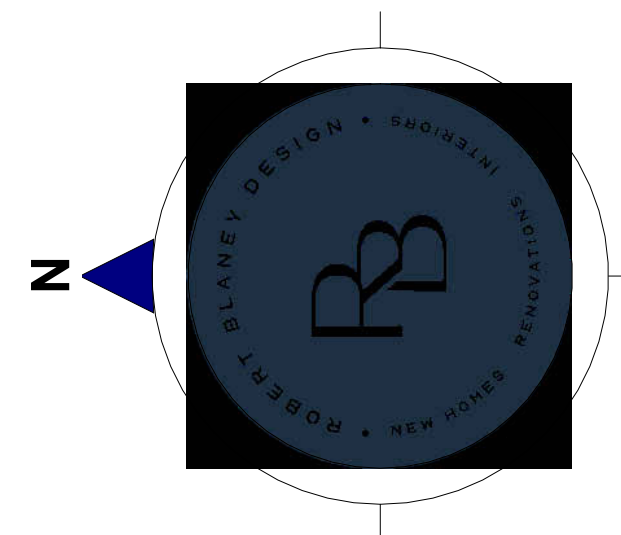

**1 FOUNDATION**  
1/4" = 1'-0"

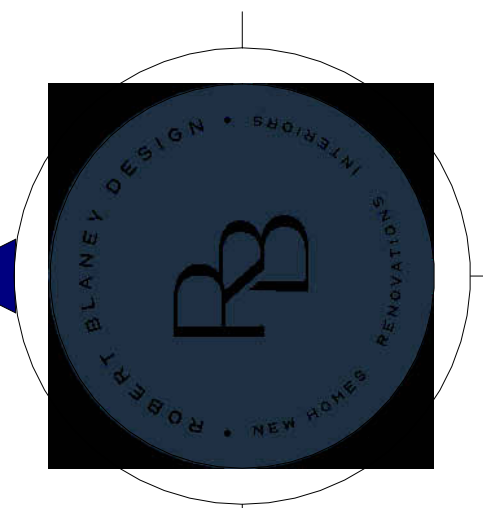

Window Schedule BASEMENT				
Level	Mark	Width	Height	Sill Height
BASEMENT	W12	5'-0"	3'-6"	4'-6"
BASEMENT	W13	5'-0"	3'-6"	4'-6"
BASEMENT	W14	5'-0"	3'-6"	4'-6"
BASEMENT	W17	5'-0"	3'-6"	4'-6"

Door Schedule BASEMENT			
Level	Mark	Width	Height
BASEMENT	8	2'-2"	8'-0"
BASEMENT	11	2'-2"	8'-0"
BASEMENT	13	2'-2"	8'-0"
BASEMENT	14	2'-6"	8'-0"
BASEMENT	23	7'-0"	8'-0"
BASEMENT	29	2'-8"	8'-0"
BASEMENT	30	2'-2"	8'-0"
BASEMENT	32	2'-6"	8'-0"
BASEMENT	34	2'-6"	8'-0"
BASEMENT	35	3'-0"	7'-0"
BASEMENT	36	2'-6"	8'-0"

Room Schedule BASEMENT			
Level	Name	Area	Perimeter
BASEMENT	BATH	38 ft <sup>2</sup>	25'-1"
BASEMENT	CLOSET	12 ft <sup>2</sup>	13'-11 3/4"
BASEMENT	FLEX	147 ft <sup>2</sup>	49'-4"
BASEMENT	KITCHEN	69 ft <sup>2</sup>	35'-10"
BASEMENT	LIVING ROOM	182 ft <sup>2</sup>	56'-10"
BASEMENT	MECHANICAL	30 ft <sup>2</sup>	23'-0 1/2"
BASEMENT	PANTRY	19 ft <sup>2</sup>	18'-5 1/2"
BASEMENT	PASSAGE	81 ft <sup>2</sup>	57'-3"
BASEMENT	SUITE BEDROOM 1	109 ft <sup>2</sup>	41'-9"
BASEMENT	SUITE BEDROOM 2	89 ft <sup>2</sup>	38'-7 1/2"
BASEMENT	SUITE PASSAGE	52 ft <sup>2</sup>	40'-7 1/2"

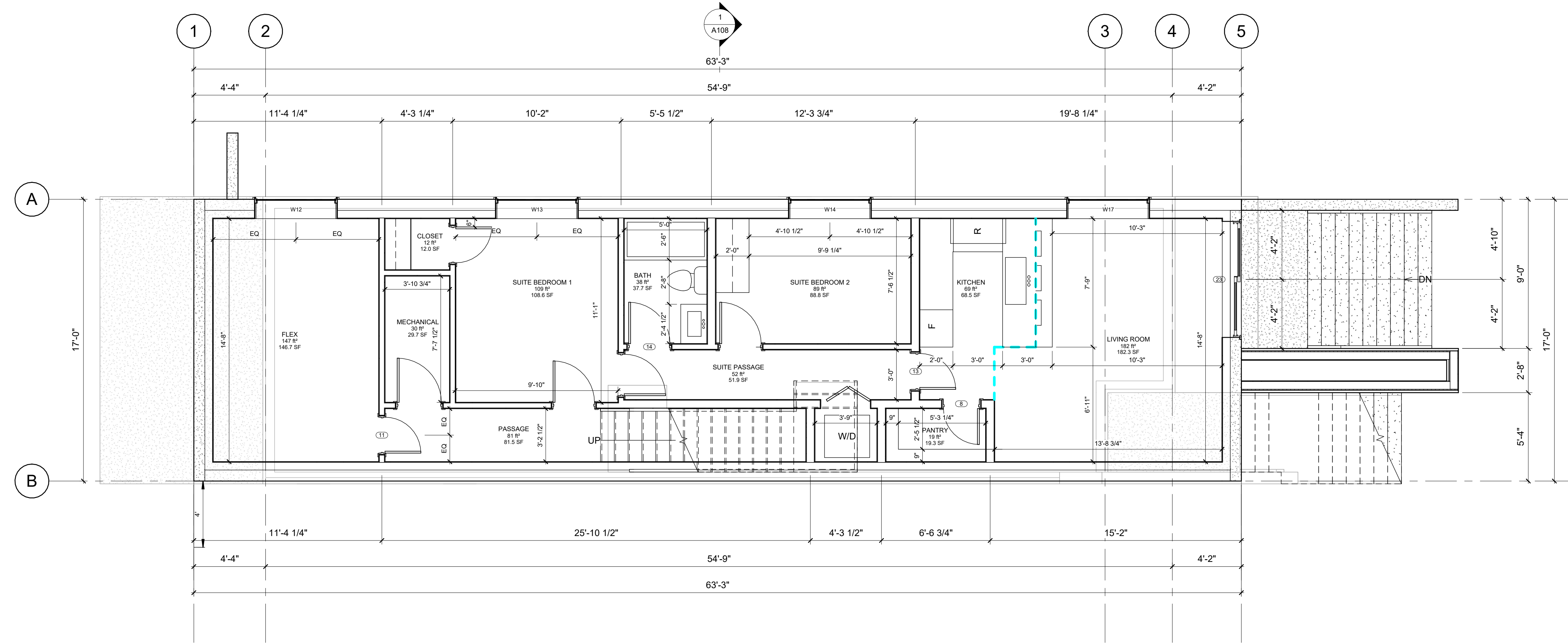

**1 BASEMENT**  
1/4" = 1'-0"



5464 PATRICIA BAY HIGHWAY,  
VICTORIA BC V8Y 2N9  
  
(604) 626-6020  
ROBERTBLANEYDESIGN@GMAIL.COM  
WWW.ROBERTBLANEYDESIGN.COM

REVISIONS  
ISSUED FOR:  
REVIEW SET: 03/06/21

PROJECT:  
NAME LOT A  
ADDRESS 528 EAST 7TH STR  
CITY NORTH VANCOUVER

DRAWING TITLE:  
BASEMENT FLOOR PLAN

SHEET:  
**A102**

DRAWN BY: SDP  
  
24X36 SCALE: 1/4" = 1'-0"  
START DATE:  
PROJECT NUMBER: Project Number

COPYRIGHT RESERVED.  
THIS DRAWING AND DESIGN ARE AND SHALL AT ALL TIMES REMAIN THE EXCLUSIVE PROPERTY OF ROBERT BLANEY DESIGN AND CANNOT BE USED OR REPRODUCED WITHOUT WRITTEN CONSENT. WRITTEN DIMENSIONS SHALL HAVE PRECEDENCE OVER SCALED DIMENSIONS. CONTRACTOR SHALL VERIFY AND SHALL BE RESPONSIBLE FOR ALL DIMENSIONS AND CONDITIONS ON THE JOB AND THIS OFFICE SHALL BE INFORMED OF ANY VARIATIONS FROM THE DIMENSIONS AND CONDITIONS AS SHOWN ON THIS DRAWING. CONTRACTORS SHALL ENSURE THAT ALL CONSTRUCTION WILL COMPLY TO ALL APPLICABLE BUILDING CODES. ROBERT BLANEY DESIGN WILL NOT ACCEPT RESPONSIBILITY FOR VARIATIONS OR MODIFICATION OF THESE PLANS.

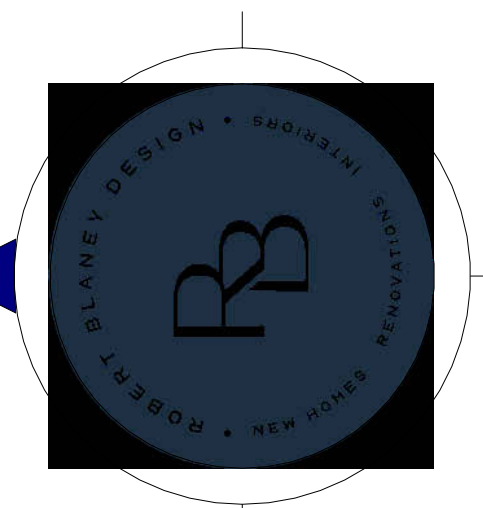

Window Schedule MAIN FLOOR				
Level	Mark	Width	Height	Sill Height
MAIN FLOOR	W1	2'-0"	6'-0"	2'-0"
MAIN FLOOR	W2	2'-0"	6'-0"	2'-0"
MAIN FLOOR	W3	6'-0"	8'-0"	1'-0"
MAIN FLOOR	W4	4'-0"	5'-0"	3'-0"
MAIN FLOOR	W5	2'-0"	2'-0"	6'-0"
MAIN FLOOR	W11	2'-0"	2'-0"	6'-0"

Door Schedule MAIN FLOOR			
Level	Mark	Width	Height
MAIN FLOOR	2	3'-0"	9'-0"
MAIN FLOOR	21	2'-2"	8'-0"
MAIN FLOOR	25	11'-0"	8'-0"
MAIN FLOOR	40	2'-2"	8'-0"

Room Schedule MAIN FLOOR			
Level	Name	Area	Perimeter
MAIN FLOOR	LIVING	155 ft <sup>2</sup>	59'-11 1/2"
MAIN FLOOR	PANTRY	22 ft <sup>2</sup>	18'-6 3/4"
MAIN FLOOR	KITCHEN	195 ft <sup>2</sup>	59'-10 3/4"
MAIN FLOOR	FAMILY	234 ft <sup>2</sup>	61'-3 1/4"
MAIN FLOOR	POWDER	26 ft <sup>2</sup>	20'-3"
MAIN FLOOR	DINING	186 ft <sup>2</sup>	57'-6 1/4"

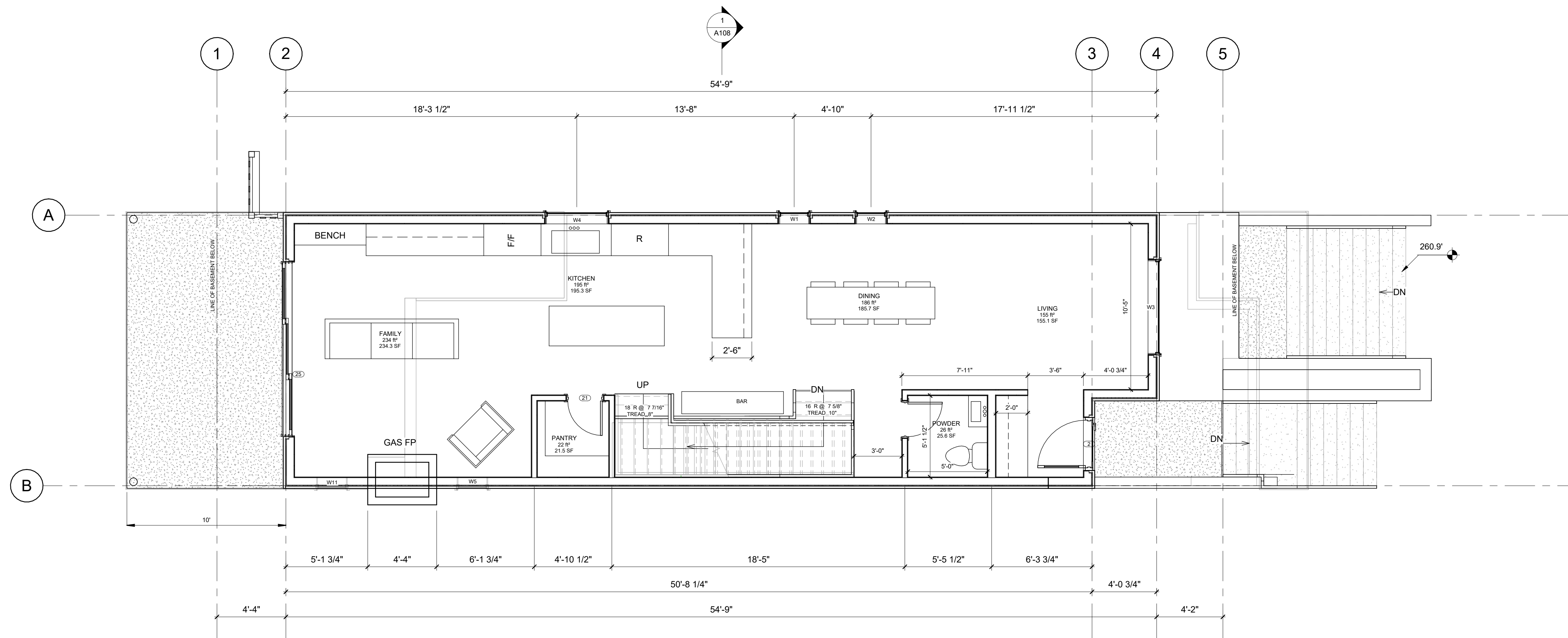

**1 MAIN FLOOR**  
1/4" = 1'-0"



5464 PATRICIA BAY HIGHWAY,  
VICTORIA BC V8Y 2N9  
  
(604) 626-6020  
ROBERTBLANEYDESIGN@GMAIL.COM  
WWW.ROBERTBLANEYDESIGN.COM

REVISIONS  
ISSUED FOR:  
REVIEW SET: 03/06/21

PROJECT:  
NAME LOT A  
ADDRESS 528 EAST 7TH STR  
CITY NORTH VANCOUVER

DRAWING TITLE:  
MAIN FLOOR PLAN

SHEET:  
**A103**

DRAWN BY: SDP  
  
24X36 SCALE: 1/4" = 1'-0"  
START DATE:  
PROJECT NUMBER: Project Number

COPYRIGHT RESERVED.  
THIS DRAWING AND DESIGN ARE AND SHALL AT ALL TIMES REMAIN THE EXCLUSIVE PROPERTY OF ROBERT BLANEY DESIGN AND CANNOT BE USED OR REPRODUCED WITHOUT WRITTEN CONSENT. WRITTEN DIMENSIONS SHALL HAVE PRECEDENCE OVER SCALED DIMENSIONS. CONTRACTOR SHALL VERIFY AND SHALL BE RESPONSIBLE FOR ALL DIMENSIONS AND CONDITIONS ON THE JOB AND THIS OFFICE SHALL BE INFORMED OF ANY VARIATIONS FROM THE DIMENSIONS AND CONDITIONS AS SHOWN ON THIS DRAWING. CONTRACTORS SHALL ENSURE THAT ALL CONSTRUCTION WILL COMPLY TO ALL APPLICABLE BUILDING CODES. ROBERT BLANEY DESIGN WILL NOT ACCEPT RESPONSIBILITY FOR VARIATIONS OR MODIFICATION OF THESE PLANS.

Window Schedule 2ND FLOOR				
Level	Mark	Width	Height	Sill Height
2ND FLOOR	W7	5'-0"	5'-0"	3'-0"
2ND FLOOR	W8	3'-0"	3'-0"	5'-0"
2ND FLOOR	W9	2'-0"	2'-0"	6'-0"
2ND FLOOR	W10	2'-0"	2'-0"	6'-0"
2ND FLOOR	W15	6'-0"	5'-0"	3'-0"
2ND FLOOR	W16	3'-0"	3'-0"	5'-0"
2ND FLOOR	W18	3'-0"	3'-0"	5'-0"
2ND FLOOR	W19	2'-0"	6'-0"	2'-0"

Door Schedule 2ND FLOOR			
Level	Mark	Width	Height
2ND FLOOR	9	2'-6"	8'-0"
2ND FLOOR	10	2'-8"	8'-0"
2ND FLOOR	15	2'-8"	8'-0"
2ND FLOOR	16	2'-6"	8'-0"
2ND FLOOR	17	2'-2"	8'-0"
2ND FLOOR	19	2'-6"	8'-0"
2ND FLOOR	38	2'-6"	8'-0"
2ND FLOOR	41	6'-0"	8'-0"

Room Schedule 2ND FLOOR			
Level	Name	Area	Perimeter
2ND FLOOR	BATH	51 ft²	30'-4"
2ND FLOOR	BEDROOM 1	125 ft²	49'-0"
2ND FLOOR	BEDROOM 2	106 ft²	45'-10"
2ND FLOOR	CLOSET	41 ft²	26'-5"
2ND FLOOR	PASSAGE	160 ft²	74'-9 3/4"
2ND FLOOR	PRIMARY BATH	82 ft²	37'-5"
2ND FLOOR	PRIMARY BED	144 ft²	54'-7"

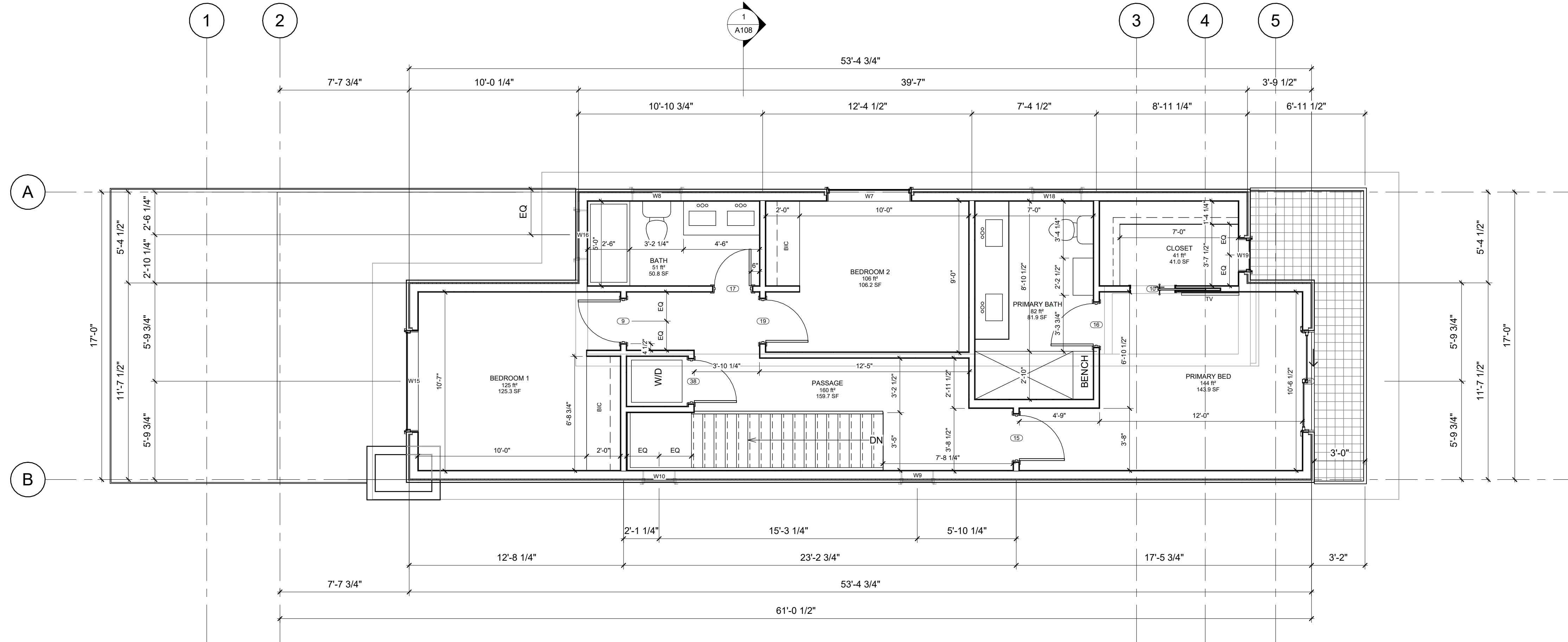
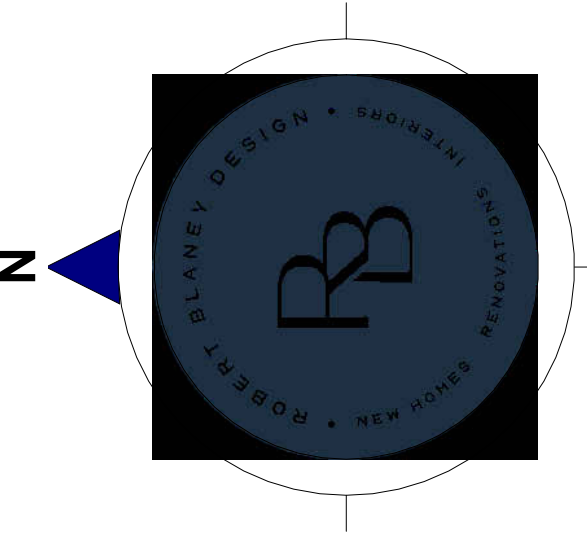

**1** 2ND FLOOR  
1/4" = 1'-0"



5464 PATRICIA BAY HIGHWAY,  
VICTORIA BC V8Y 2N9  
  
(604) 626-6020  
ROBERTBLANEYDESIGN@GMAIL.COM  
WWW.ROBERTBLANEYDESIGN.COM

REVISIONS  
ISSUED FOR:  
REVIEW SET: 05/24/21

PROJECT:  
NAME LOT A  
ADDRESS 528 EAST 7TH STR  
CITY NORTH VANCOUVER

DRAWING TITLE:  
2ND FLOOR PLAN

SHEET:  
**A104**

DRAWN BY: SDP  
  
24X36 SCALE: 1/4" = 1'-0"  
START DATE:

PROJECT NUMBER:  
Project Number

COPYRIGHT RESERVED.  
  
THIS DRAWING AND DESIGN ARE AND SHALL AT ALL TIMES REMAIN THE EXCLUSIVE PROPERTY OF ROBERT BLANEY DESIGN AND CANNOT BE USED OR REPRODUCED WITHOUT WRITTEN CONSENT. WRITTEN DIMENSIONS SHALL HAVE PRECEDENCE OVER SCALED DIMENSIONS. CONTRACTOR SHALL VERIFY AND SHALL BE RESPONSIBLE FOR ALL DIMENSIONS AND CONDITIONS ON THE JOB AND THIS OFFICE SHALL BE INFORMED OF ANY VARIATIONS FROM THE DIMENSIONS AND CONDITIONS AS SHOWN ON THIS DRAWING. CONTRACTORS SHALL ENSURE THAT ALL CONSTRUCTION WILL COMPLY TO ALL APPLICABLE BUILDING CODES. ROBERT BLANEY DESIGN WILL NOT ACCEPT RESPONSIBILITY FOR VARIATIONS OR MODIFICATION OF THESE PLANS.

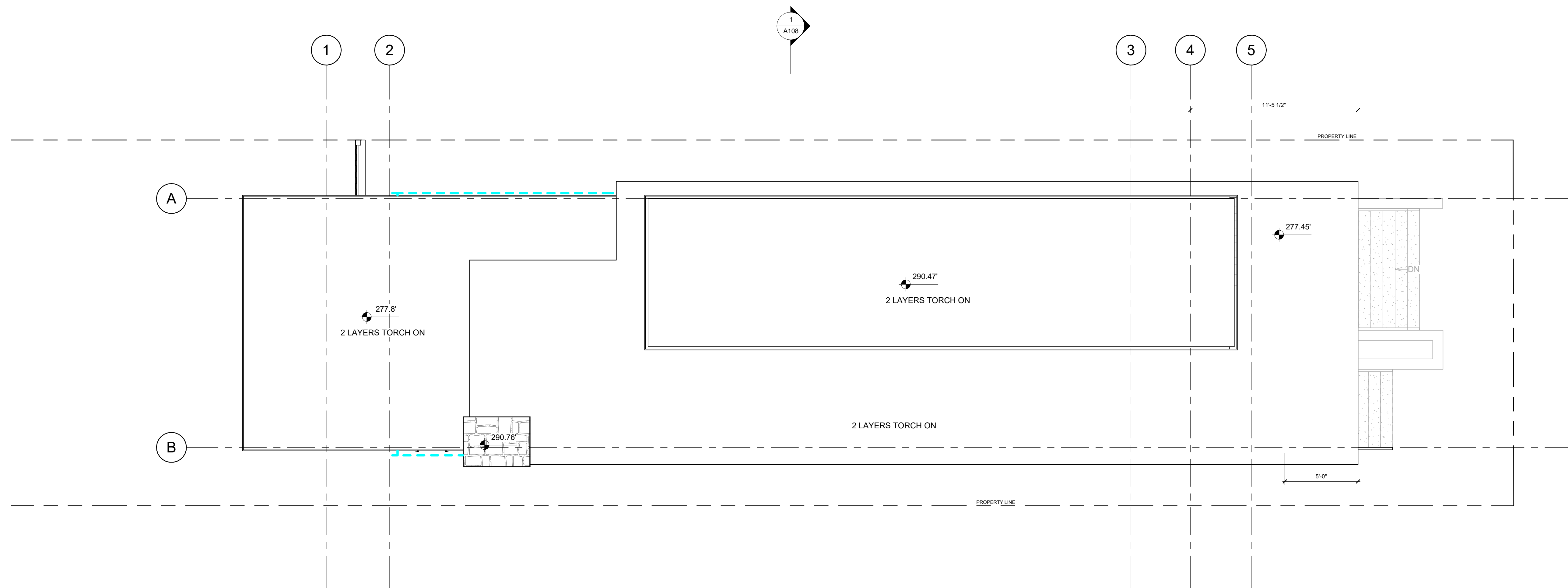
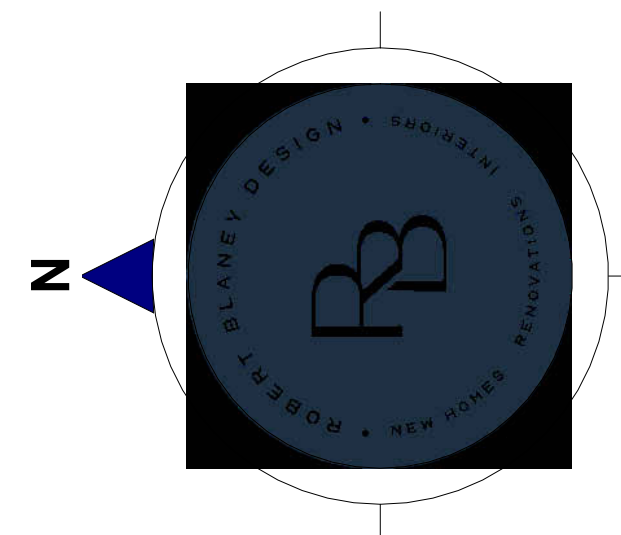

**1** ROOF  
1/4" = 1'-0"



- MAIN FLOOR
- MAIN FLOOR
- MAIN FLOOR
- 2ND FLOOR
- 2ND FLOOR
- 2ND FLOOR
- 2ND FLOOR
- 2ND FLOOR
- MAIN FLOOR
- BASEMENT
- BASEMENT
- BASEMENT
- 2ND FLOOR
- 2ND FLOOR
- BASEMENT
- 2ND FLOOR
- 2ND FLOOR

Level
MAIN FLOOR
BASEMENT
GARAGE T.O
SLAB
2ND FLOOR



F



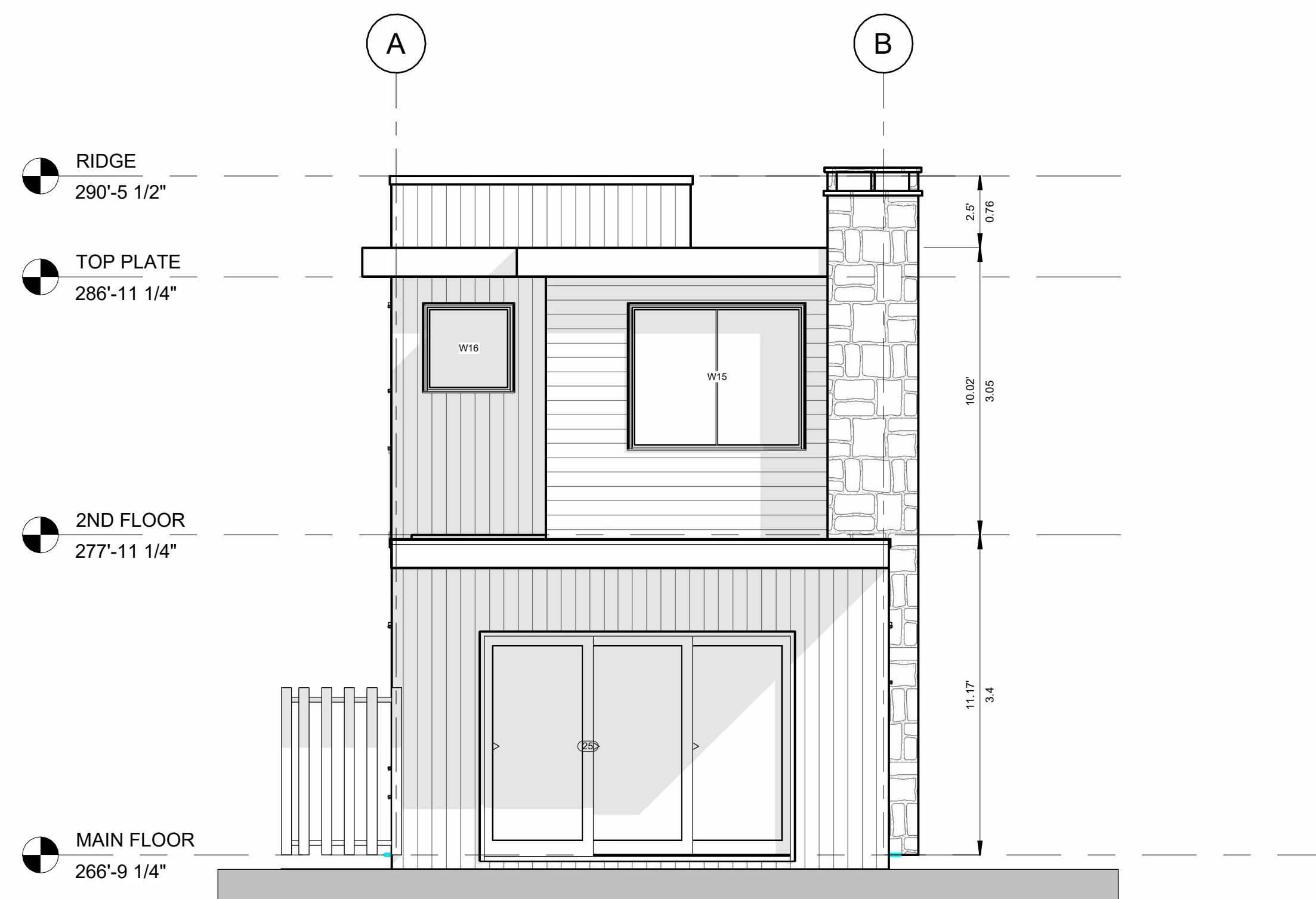
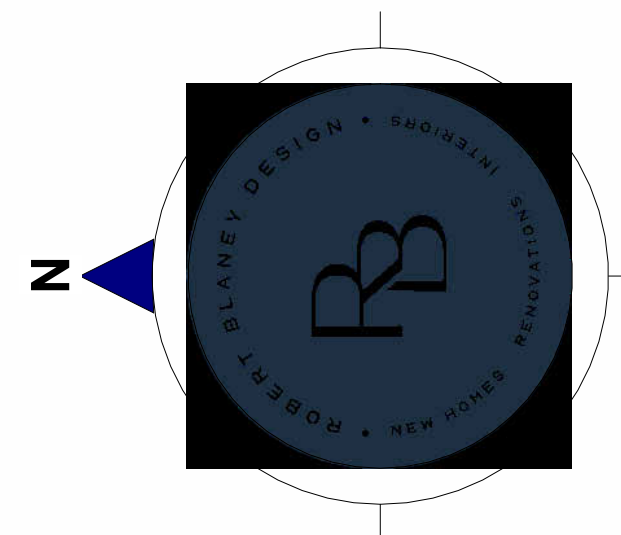

**1 North**  
1/4" = 1'-0"

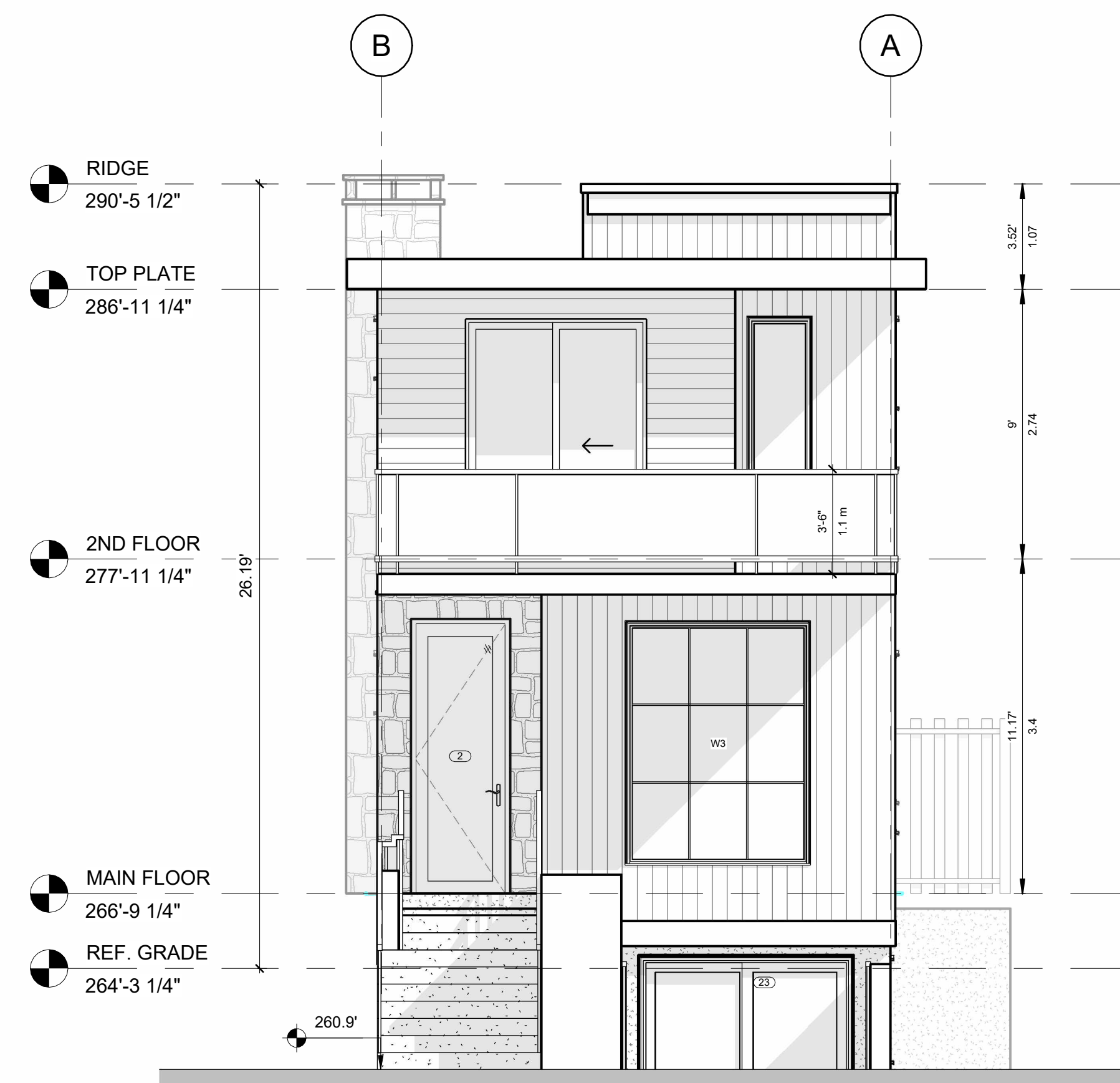

**2 South**  
1/4" = 1'-0"

LEGEND	
HARDIE SHAKES (WHITE)	A
STONE (TBD)	B
ASPHALT SHINGLES	C
STANDING SEAM METAL	D

Door Schedule EXTERIOR				
Level	Mark	Width	Height	Function
MAIN FLOOR	2	3'-0"	9'-0"	Exterior
BASEMENT	23	7'-0"	8'-0"	Exterior
GARAGE T.O SLAB	28	3'-0"	6'-8"	Exterior
2ND FLOOR	41	6'-0"	8'-0"	Exterior

Window Schedule ALL FLOORS					
Level	Mark	Sill Height	Width	Height	Area
MAIN FLOOR	W1	2'-0"	2'-0"	6'-0"	12 ft <sup>2</sup>
MAIN FLOOR	W2	2'-0"	2'-0"	6'-0"	12 ft <sup>2</sup>
MAIN FLOOR	W3	1'-0"	6'-0"	8'-0"	48 ft <sup>2</sup>
MAIN FLOOR	W4	3'-0"	4'-0"	5'-0"	20 ft <sup>2</sup>
MAIN FLOOR	W5	6'-0"	2'-0"	2'-0"	4 ft <sup>2</sup>
2ND FLOOR	W7	3'-0"	5'-0"	5'-0"	25 ft <sup>2</sup>
2ND FLOOR	W8	5'-0"	3'-0"	3'-0"	9 ft <sup>2</sup>
2ND FLOOR	W9	6'-0"	2'-0"	2'-0"	4 ft <sup>2</sup>
2ND FLOOR	W10	6'-0"	2'-0"	2'-0"	4 ft <sup>2</sup>
MAIN FLOOR	W11	6'-0"	2'-0"	2'-0"	4 ft <sup>2</sup>
BASEMENT	W12	4'-6"	5'-0"	3'-6"	18 ft <sup>2</sup>
BASEMENT	W13	4'-6"	5'-0"	3'-6"	18 ft <sup>2</sup>
BASEMENT	W14	4'-6"	5'-0"	3'-6"	18 ft <sup>2</sup>
2ND FLOOR	W15	3'-0"	6'-0"	5'-0"	30 ft <sup>2</sup>
2ND FLOOR	W16	5'-0"	3'-0"	3'-0"	9 ft <sup>2</sup>
BASEMENT	W17	4'-6"	5'-0"	3'-6"	18 ft <sup>2</sup>
2ND FLOOR	W18	5'-0"	3'-0"	3'-0"	9 ft <sup>2</sup>
2ND FLOOR	W19	2'-0"	2'-0"	6'-0"	12 ft <sup>2</sup>



5464 PATRICIA BAY HIGHWAY,  
VICTORIA BC V8Y 2N9  
  
(604) 626-6020  
ROBERTBLANEYDESIGN@GMAIL.COM  
WWW.ROBERTBLANEYDESIGN.COM

REVISIONS  
ISSUED FOR:  
REVIEW SET: 03/06/21

PROJECT:  
NAME LOT A  
ADDRESS 528 EAST 7TH STR  
CITY NORTH VANCOUVER

DRAWING TITLE:  
ELEVATIONS - NORTH & SOUTH

SHEET:

**A107**

DRAWN BY: SDP

24X36 SCALE:  
1/4" = 1'-0"

START DATE:

PROJECT NUMBER:  
Project Number

COPYRIGHT RESERVED.

THIS DRAWING AND DESIGN ARE AND SHALL AT ALL TIMES REMAIN THE EXCLUSIVE PROPERTY OF ROBERT BLANEY DESIGN AND CANNOT BE USED OR REPRODUCED WITHOUT WRITTEN CONSENT. WRITTEN DIMENSIONS SHALL HAVE PRECEDENCE OVER SCALED DIMENSIONS. CONTRACTOR SHALL VERIFY AND SHALL BE RESPONSIBLE FOR ALL DIMENSIONS AND CONDITIONS ON THE JOB AND THIS OFFICE SHALL BE INFORMED OF ANY VARIATIONS FROM THE DIMENSIONS AND CONDITIONS AS SHOWN ON THIS DRAWING. CONTRACTORS SHALL ENSURE THAT ALL CONSTRUCTION WILL COMPLY TO ALL APPLICABLE BUILDING CODES. ROBERT BLANEY DESIGN WILL NOT ACCEPT RESPONSIBILITY FOR VARIATIONS OR MODIFICATION OF THESE PLANS.

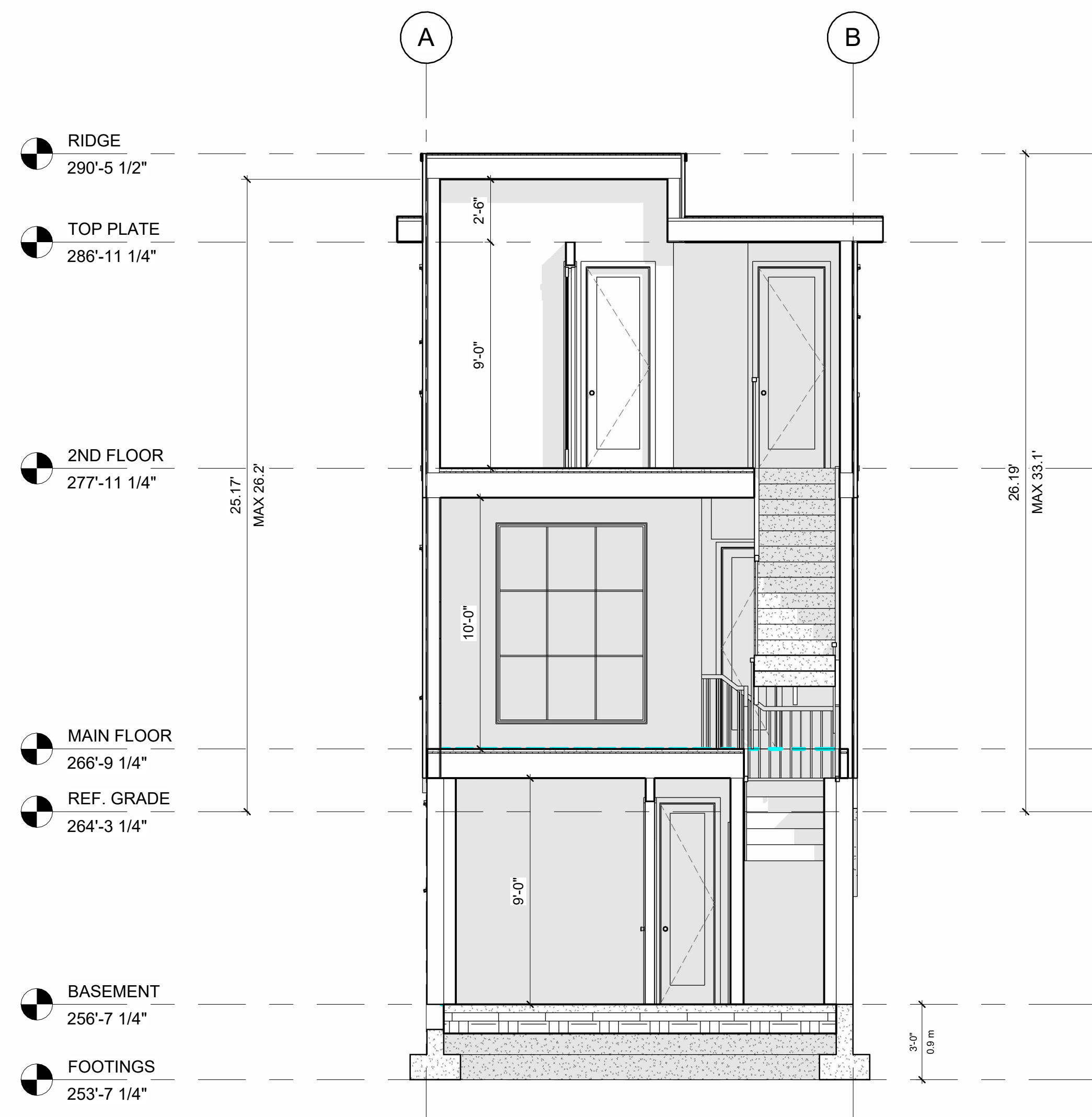
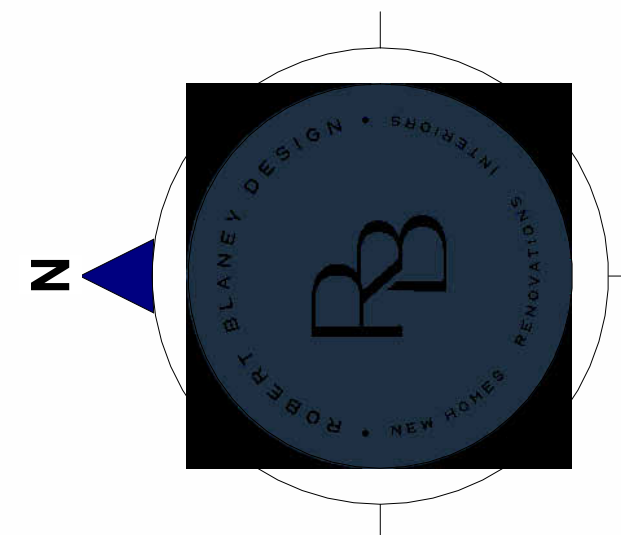

**1 Section 1**  
1/4" = 1'-0"

**W1 EXTERIOR WALL (ABOVE GRADE)**

CLADDING  
1/2" PURLINS OR RAIN-SCREEN SYSTEM  
TYVEK SEALED & TAPED  
1/2" PLYWOOD SHEATHING  
2X6" STUDS @ 16" O.C  
BATT INSULATION (R24)  
6MIL POLY V.B  
1/2" G.W.B PAINTED  
AIR FILM (INTERIOR)

**W2 FURRED FOUNDATION WALL**

DRAINAGE MAT W/ FILTER FABRIC  
2 COATS OF BITUMINOUS SEALANT  
8" FOUNDATION WALL  
2X6" STUDS @ 16" O.C  
BATT INSULATION (R22)  
6MIL POLY V.B.  
1/2" G.W.B  
AIR FILM (INTERIOR)

**W3 FOUNDATION WALL**

DRAINAGE MAT W/ FILTER FABRIC  
2 COATS OF BITUMINOUS SEALANT  
8" CONCRETE WALL

**W4 INTERIOR WALL - 2x6"**

1/2" G.W.B BOTH SIDES  
2X6" STUDS @ 16" O.C

**F1 FLOOR OVER CONDITIONED SPACE**

FLOOR FINISH  
1-1/2" CONCRETE TOPPING  
3/4" T&G FLOOR SHEATHING GLUED & SCREWED  
11-7/8" TJI JOISTS @ 12" O.C  
1/2" G.W.B PAINTED

**F2 FLOOR OVER UNCONDITIONED SPACE**

FLOOR FINISH  
1-1/2" CONCRETE TOPPING  
3/4" T&G FLOOR SHEATHING GLUED & SCREWED  
11-7/8" TJI JOISTS @ 16" O.C  
SPRAY FOAM CLOSED CELL INSUL (R28)

**F3 BASEMENT SLAB**

FLOOR FINISH  
4" REINFORCED CONCRETE SLAB  
6MIL POLY V.B  
3" RIGID INSULATION UNDER SLAB (R16)  
6" MIN. COMPACTED GRANULAR BASE  
RADON GAS VENTED

**F4 PATIO SLAB/DRIVEWAY ON GRADE**

4" REINFORCED CONCRETE SLAB  
6" MIN. COMPACTED GRANULAR BASE

**R1 FLAT ROOF**

2 LAYERS TORCH ON ROOFING  
3/4" ROOF SHAETHING  
2X4" CROSS STRAPPING @ 16" O.C  
9.5" TGI RAFTERS @ 16" O.C  
BATT INSULATION (R28)  
6MIL POLY V.B. TAPED AND SEALED  
1/2" G.W.B PAINTED  
AIR FILM (INTERIOR)

REVISIONS  
ISSUED FOR:  
REVIEW SET: 03/07/21

PROJECT:  
NAME LOT A  
ADDRESS 528 EAST 7TH STR  
CITY NORTH VANCOUVER

SHEET:  
**A108**

DRAWN BY: SDP  
24X36 SCALE: 1/4" = 1'-0"  
PROJECT NUMBER: Project Number  
START DATE:

COPYRIGHT RESERVED.  
THIS DRAWING AND DESIGN ARE AND SHALL AT ALL TIMES REMAIN THE EXCLUSIVE PROPERTY OF ROBERT BLANEY DESIGN AND CANNOT BE USED OR REPRODUCED WITHOUT WRITTEN CONSENT. WRITTEN DIMENSIONS SHALL HAVE PRECEDENCE OVER SCALED DIMENSIONS. CONTRACTOR SHALL VERIFY AND SHALL BE RESPONSIBLE FOR ALL DIMENSIONS AND CONDITIONS ON THE JOB AND THIS OFFICE SHALL BE INFORMED OF ANY VARIATIONS FROM THE DIMENSIONS AND CONDITIONS AS SHOWN ON THIS DRAWING. CONTRACTORS SHALL ENSURE THAT ALL CONSTRUCTION WILL COMPLY TO ALL APPLICABLE BUILDING CODES. ROBERT BLANEY DESIGN WILL NOT ACCEPT RESPONSIBILITY FOR VARIATIONS OR MODIFICATION OF THESE PLANS.

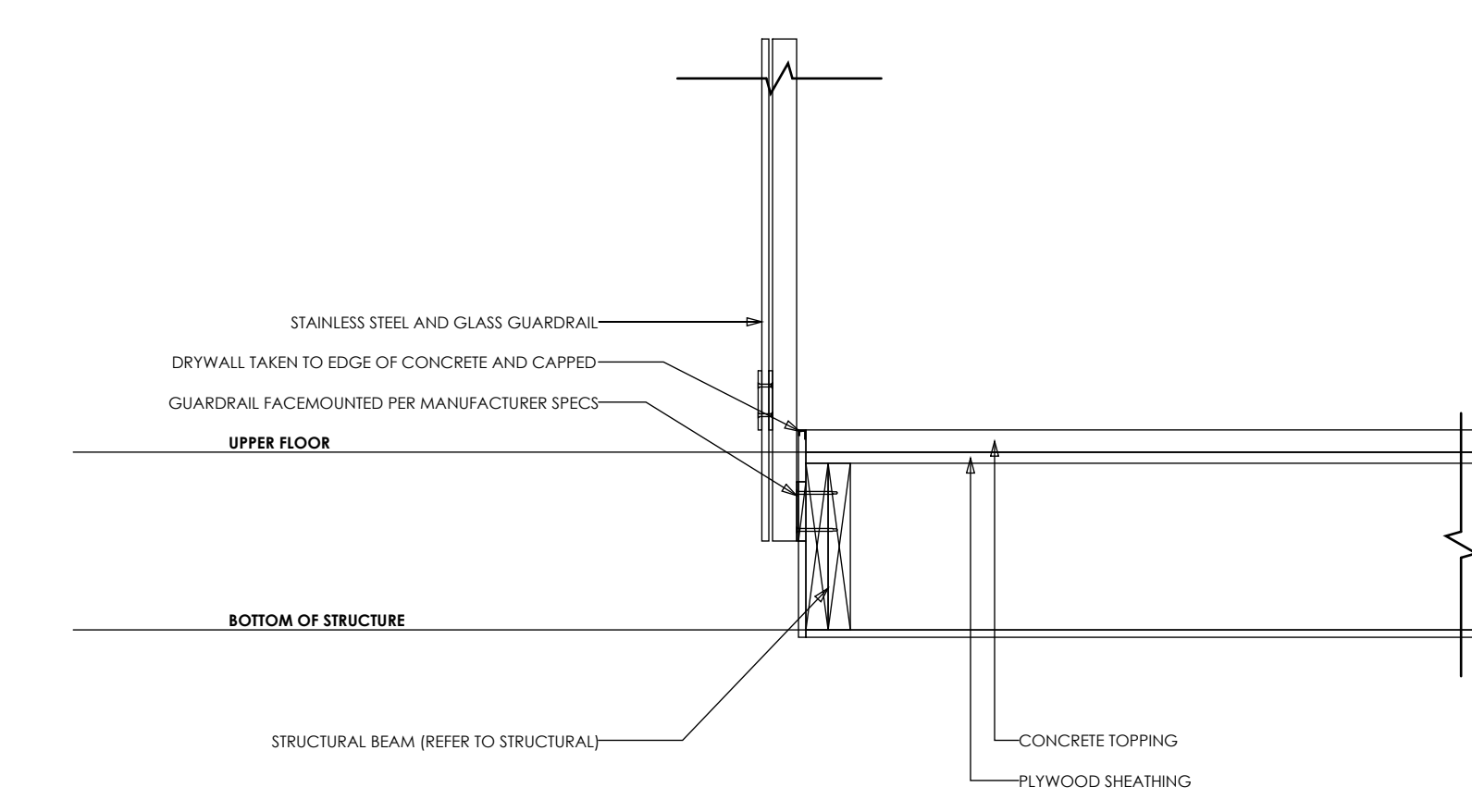
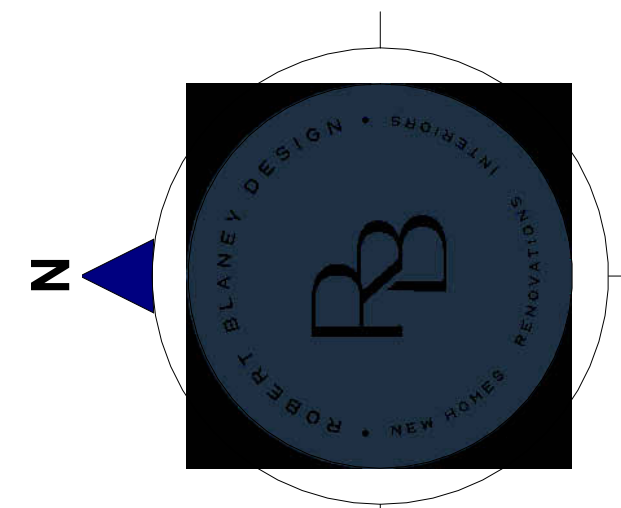

**10 GUARDRAIL**  
1" = 1'-0"

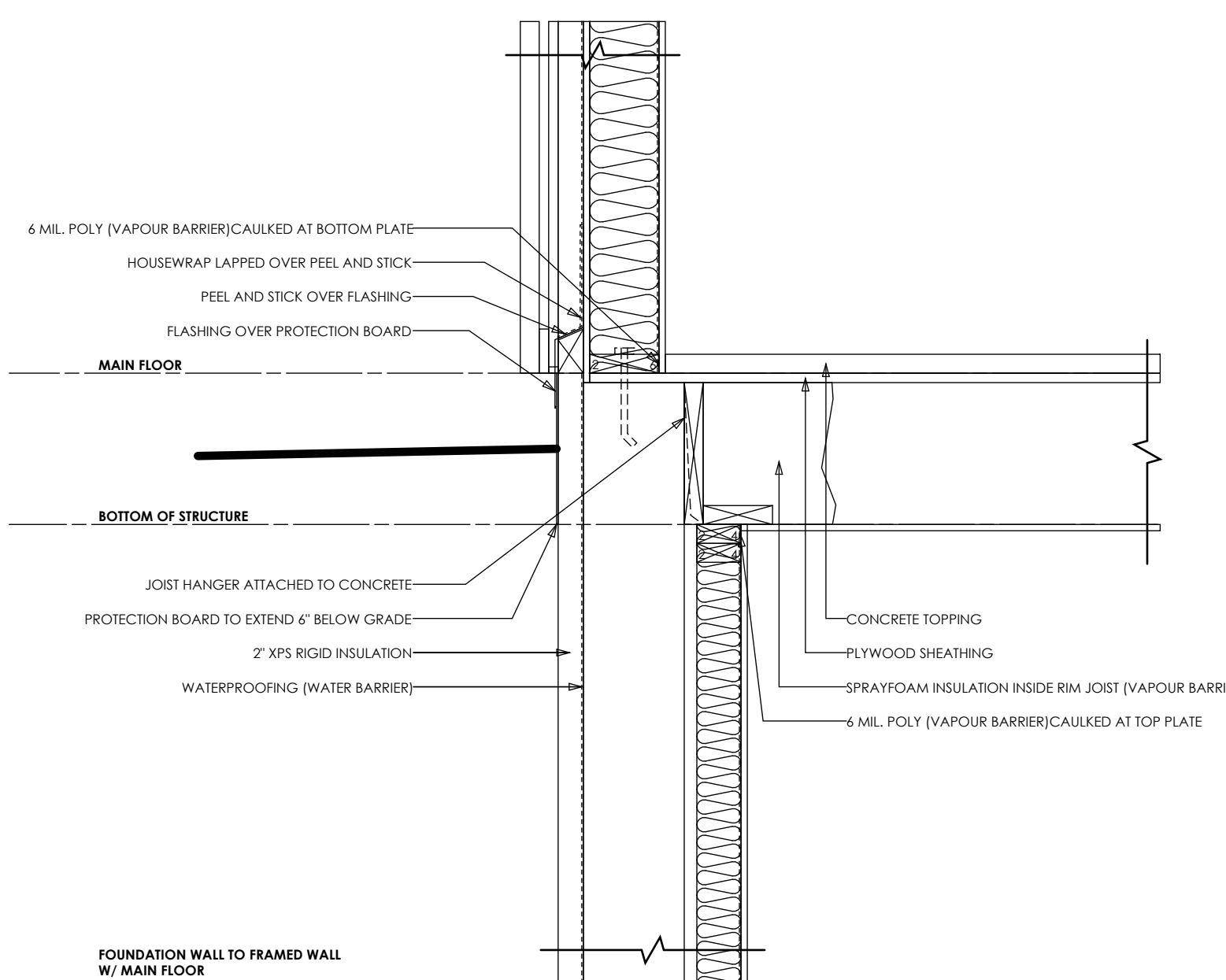

**5 FOUNDATION WALL TO FRAMED WALL W/ MAIN FLOOR**  
1" = 1'-0"

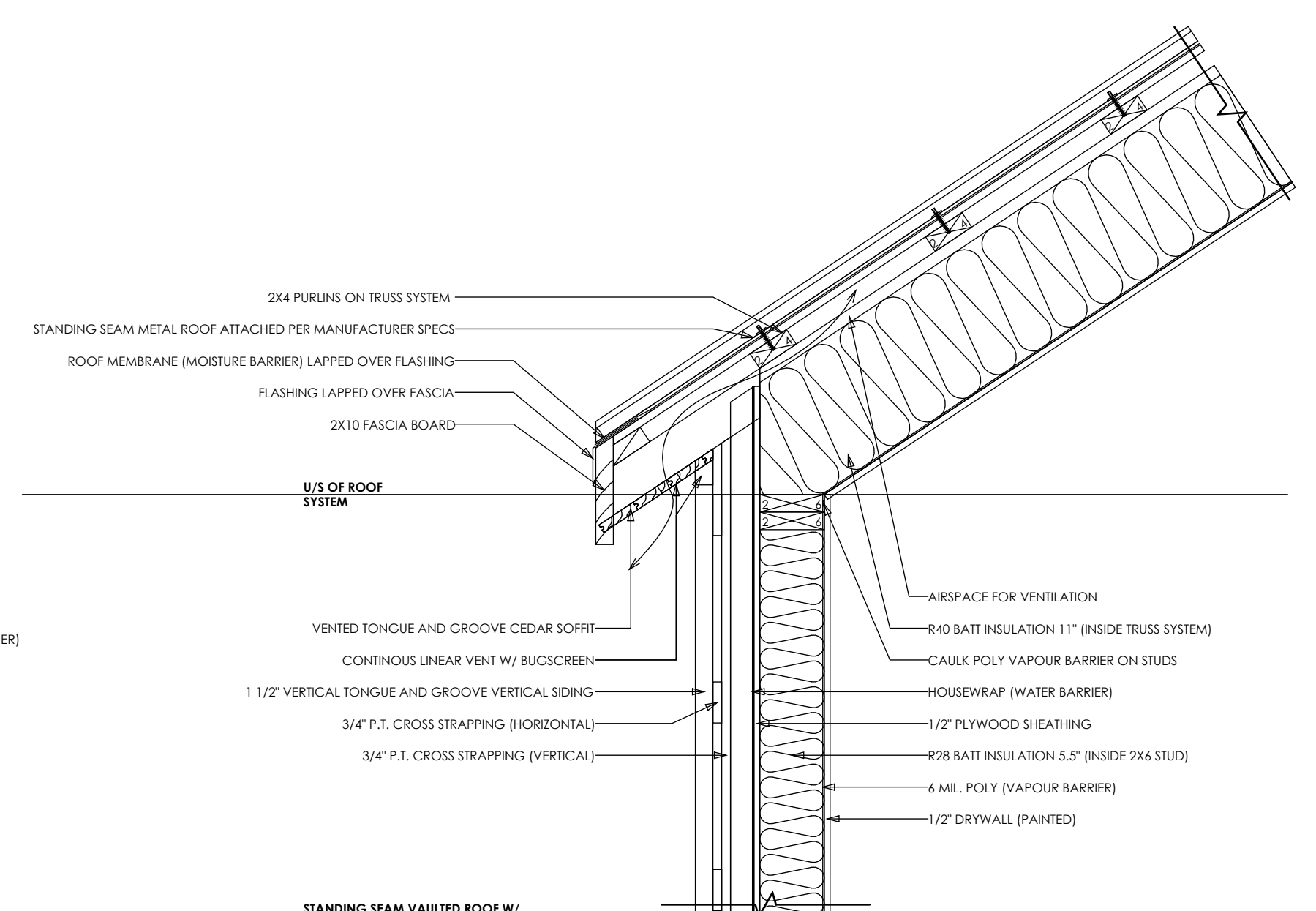

**7 STANDING SEAM VAULTED ROOF W/ HAND-FRAMED STRUCTURE (2X12)**  
1" = 1'-0"

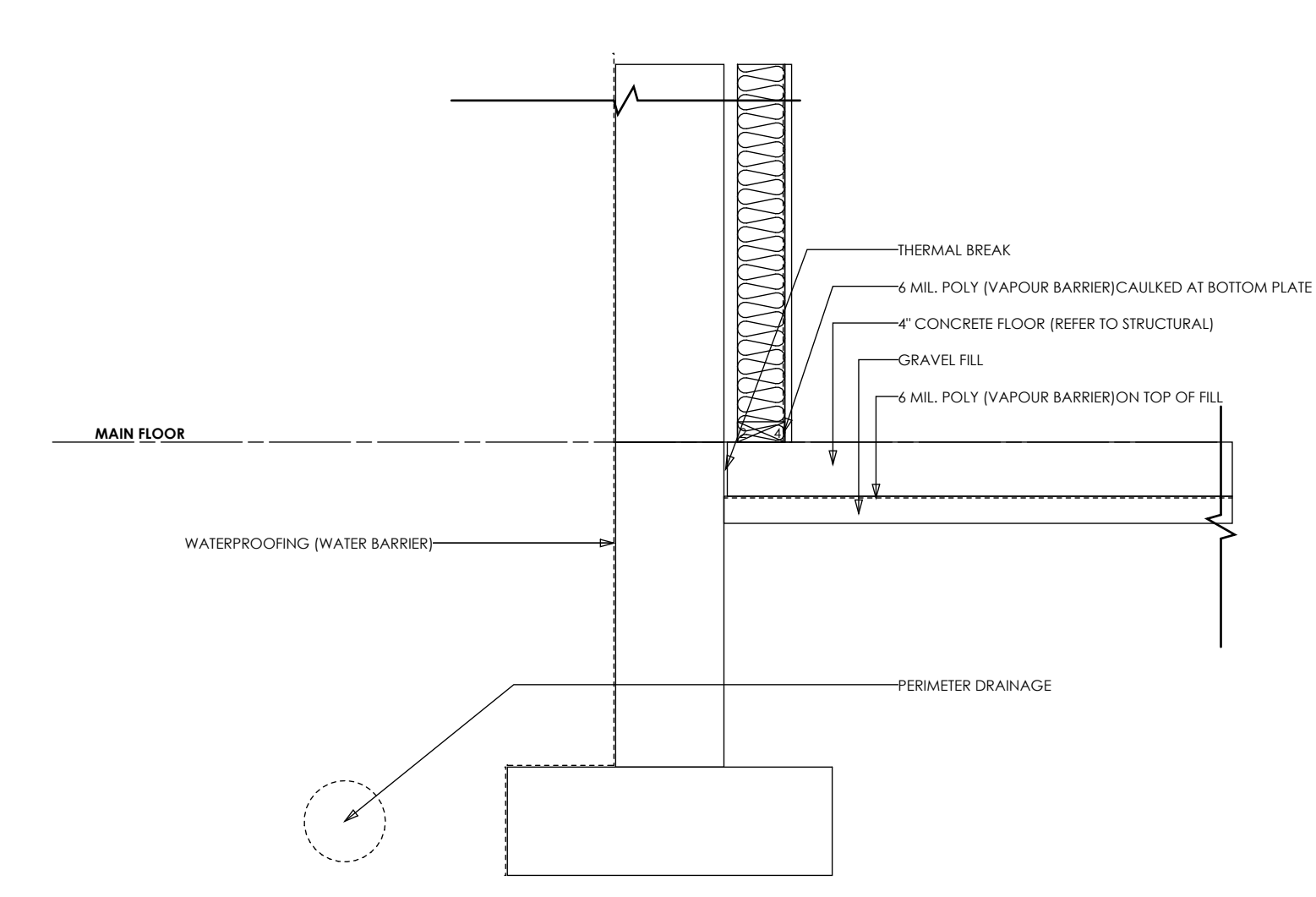

**4 FOOTING TO FOUNDATION**  
1" = 1'-0"

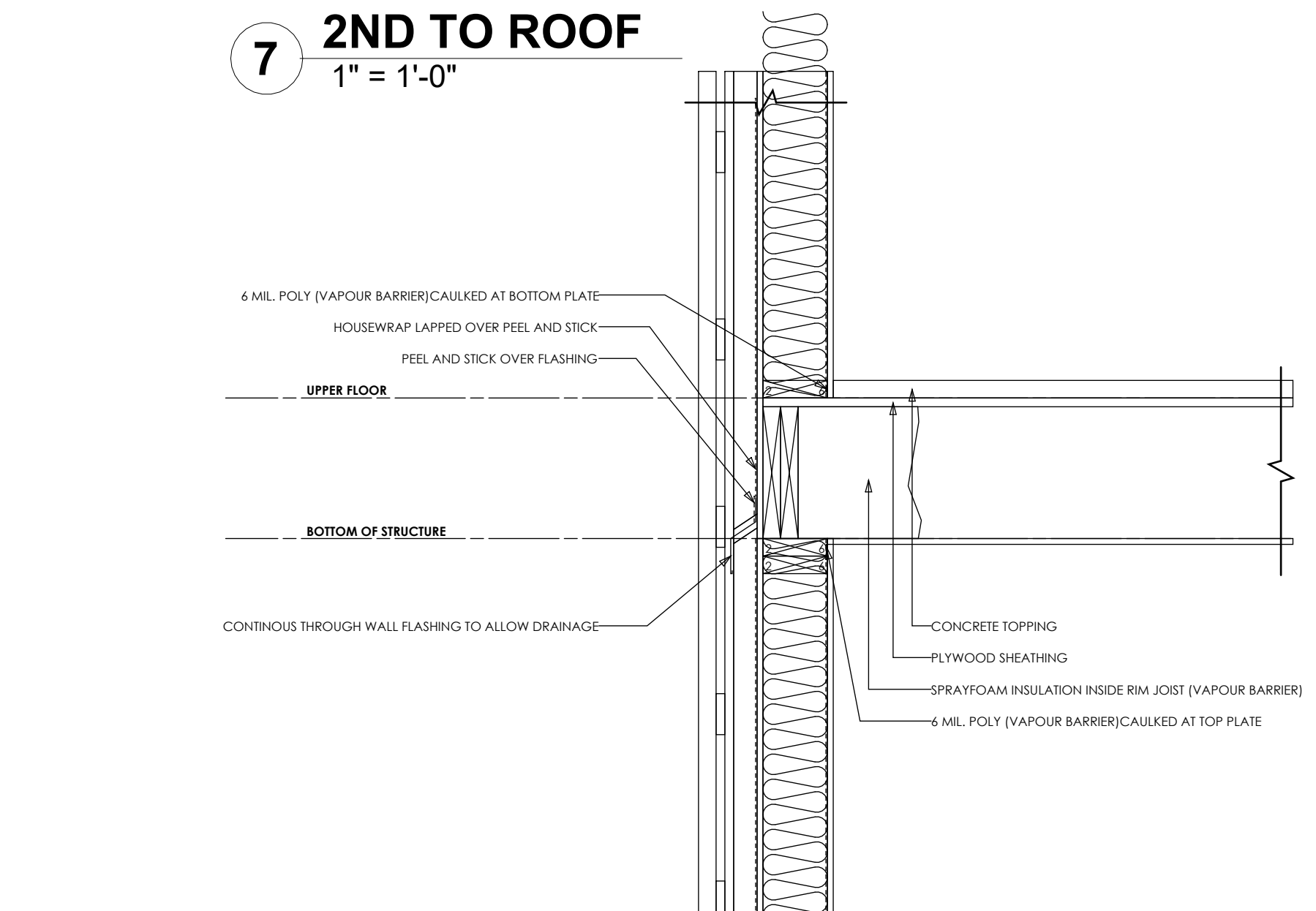

**6 UPPER FLOOR TO MAIN FLOOR WALL CONNECTION**  
1" = 1'-0"

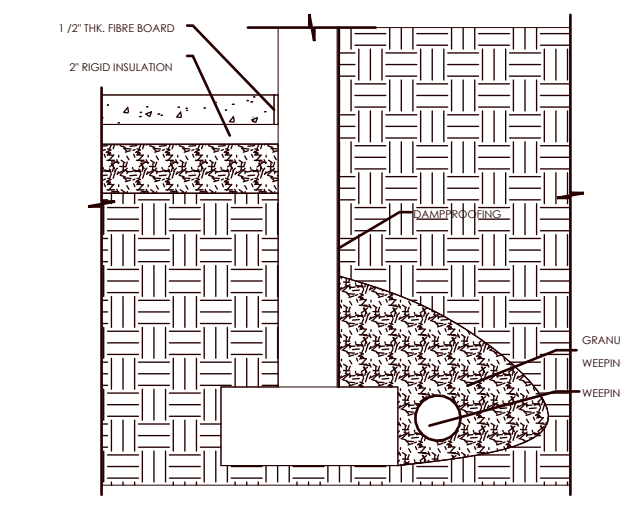

**2 FOUNDATION**

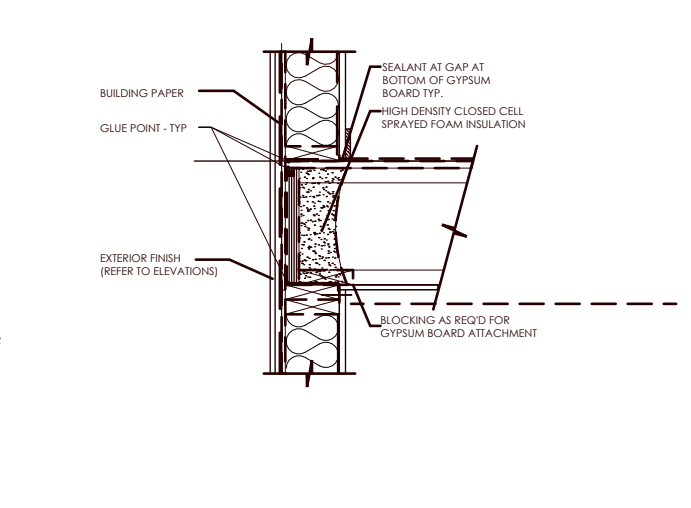

**3 FLOOR JOIST**

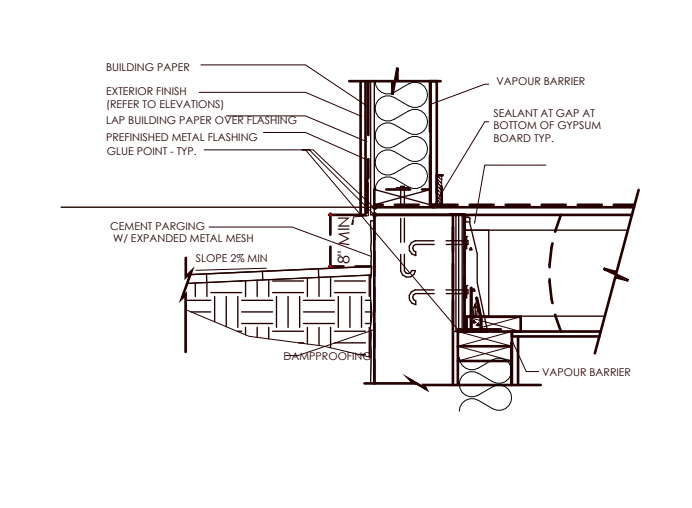

**4 FLOOR JOIST**

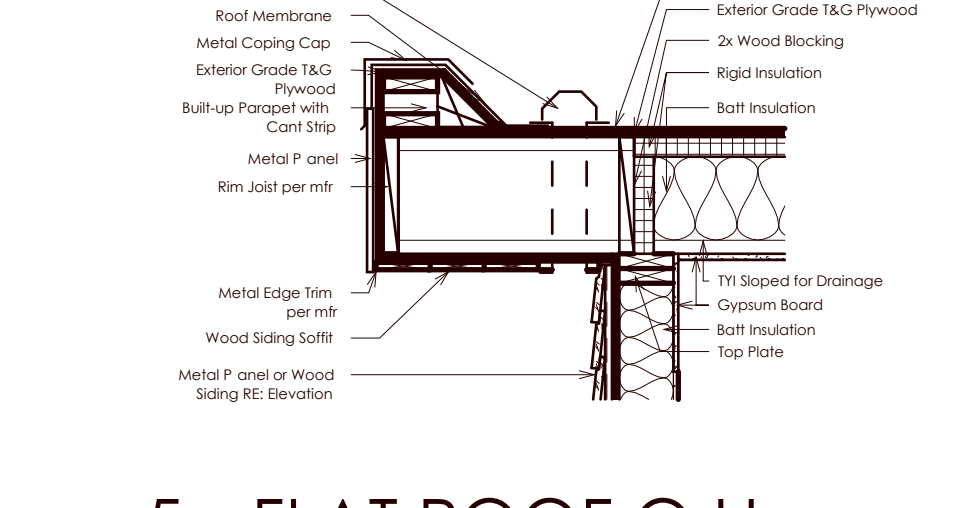

**5 FLAT ROOF O.H**

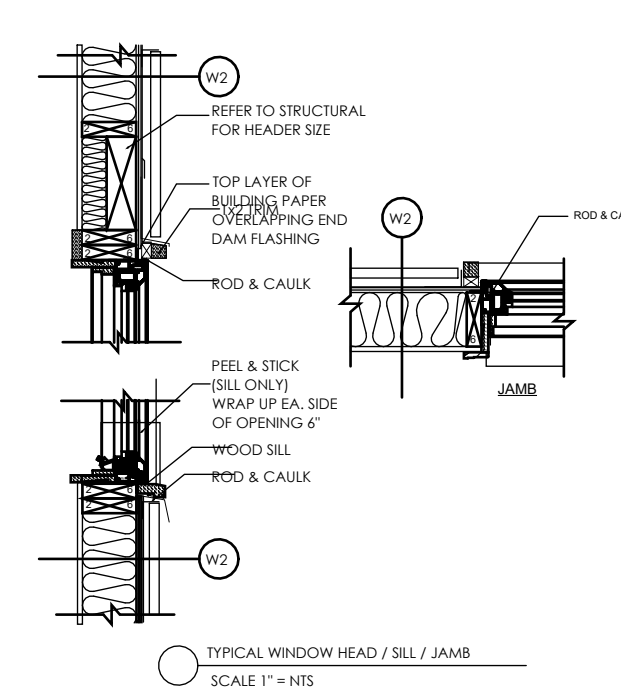

**1 TYPICAL WINDOW HEAD / SILL / JAMB**  
SCALE 1" = 1/4"

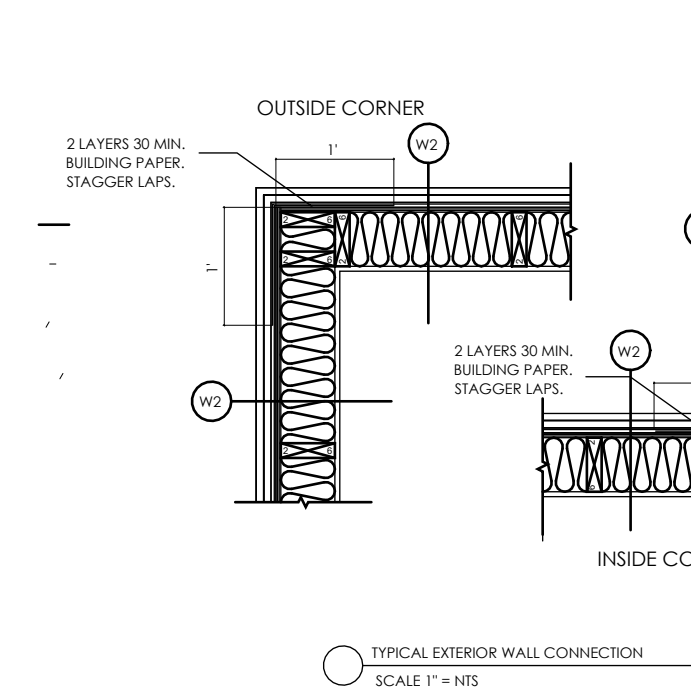

**2 TYPICAL EXTERIOR WALL CONNECTION**  
SCALE 1" = 1/4"

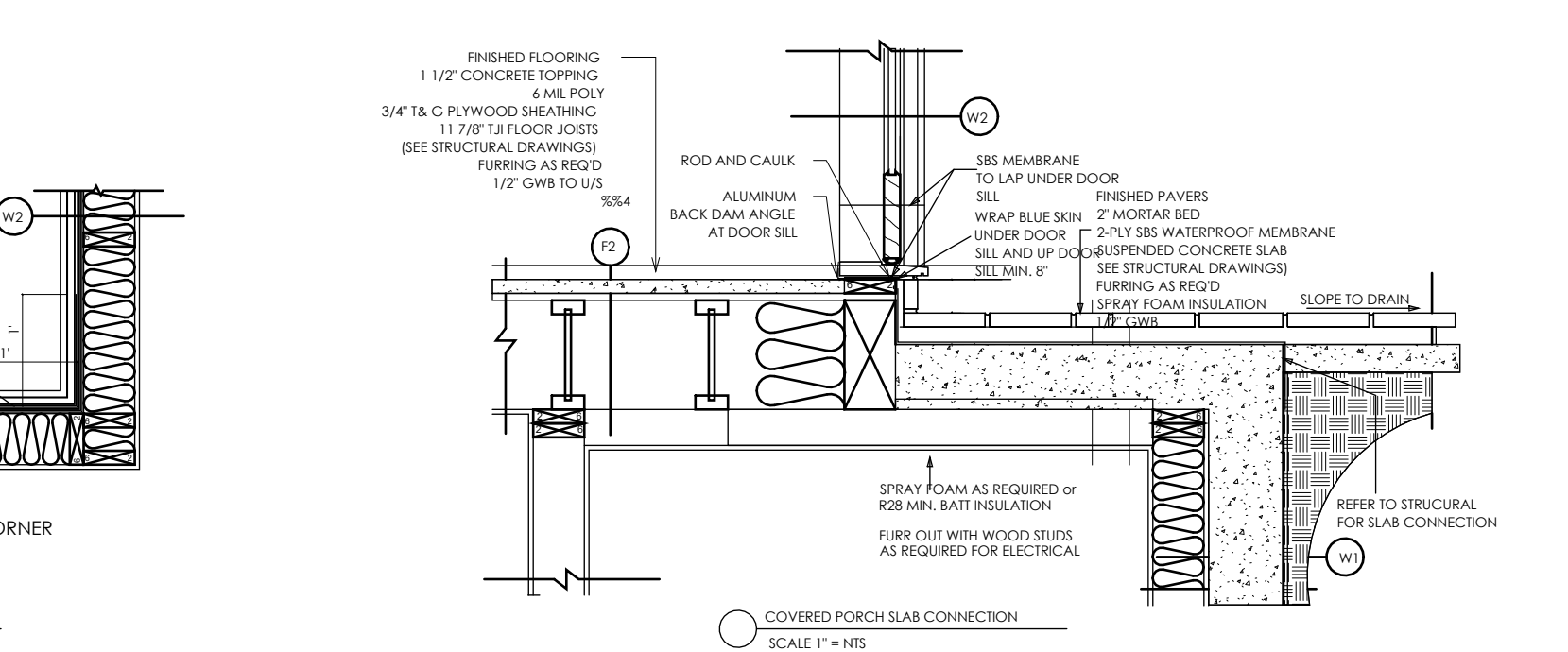

**3 COVERED PORCH SLAB CONNECTION**  
SCALE 1" = 1/4"

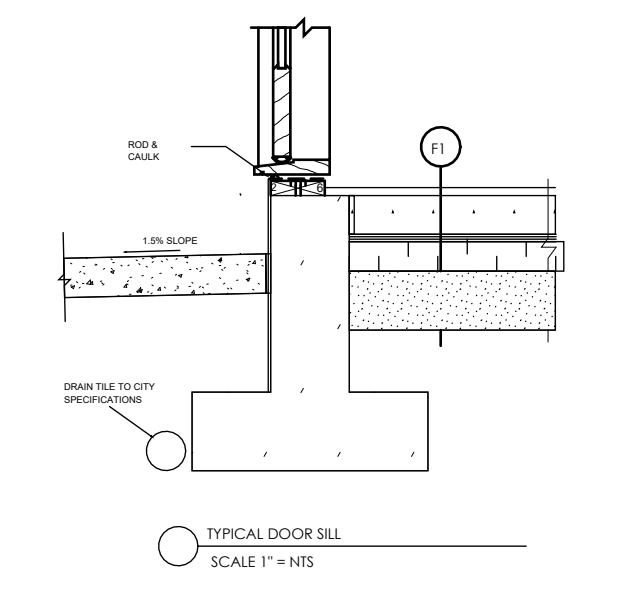

**4 TYPICAL DOOR SILL**  
SCALE 1" = 1/4"

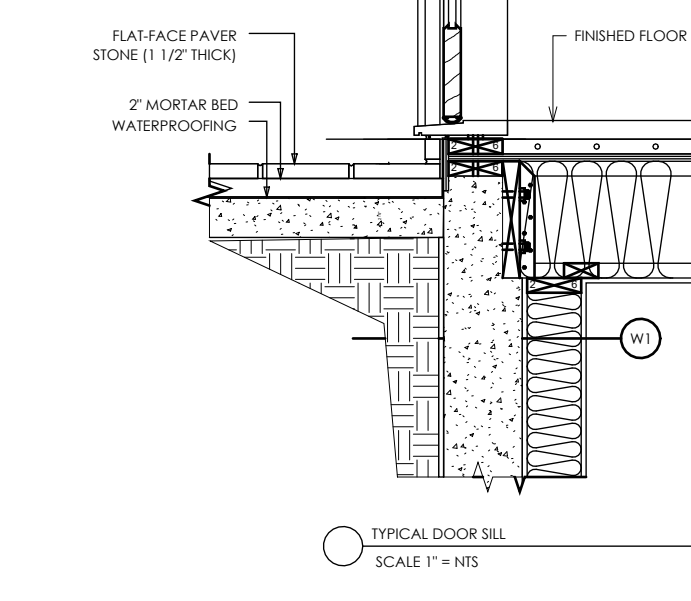

**5 TYPICAL DOOR SILL**  
SCALE 1" = 1/4"

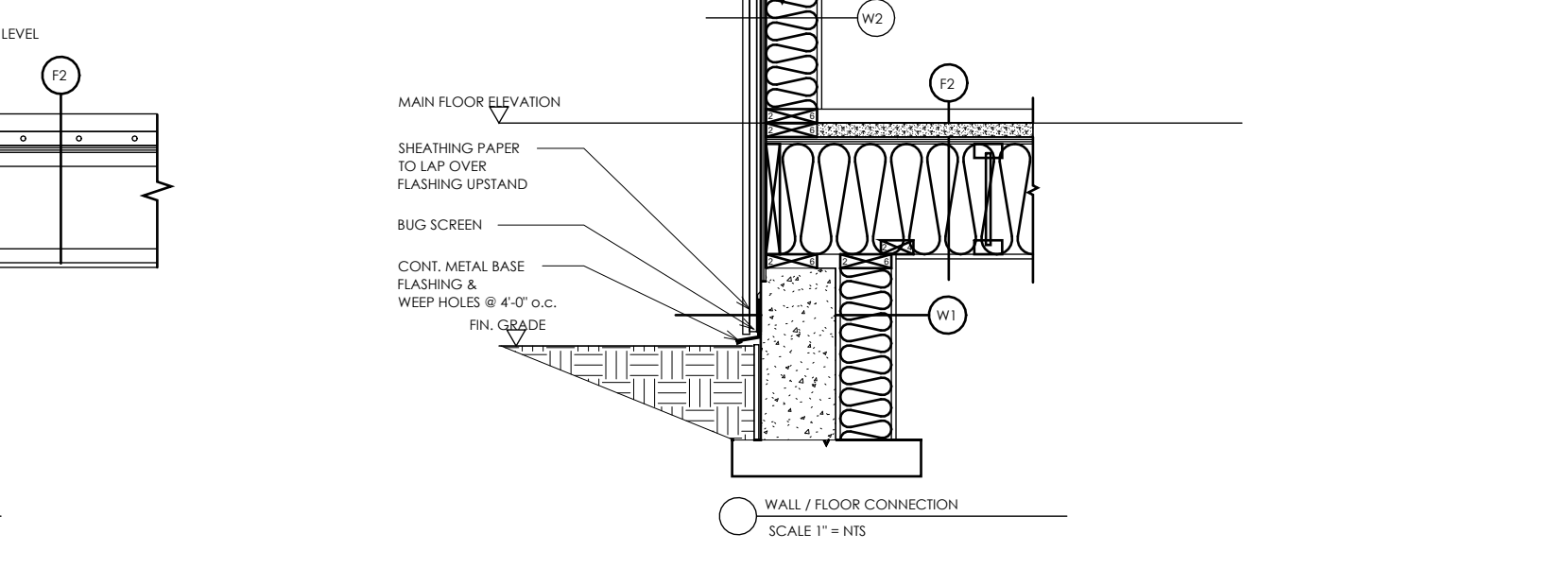

**6 WALL / FLOOR CONNECTION**  
SCALE 1" = 1/4"

REVISIONS	PROJECT:
ISSUED FOR:	NAME LOT A
REVIEW SET:	ADDRESS 528 EAST 7TH STR
	CITY NORTH VANCOUVER
	DRAWING TITLE: DETAILS

REVISIONS	PROJECT:
ISSUED FOR:	NAME LOT A
REVIEW SET:	ADDRESS 528 EAST 7TH STR
	CITY NORTH VANCOUVER
	DRAWING TITLE: DETAILS

REVISIONS	PROJECT:
ISSUED FOR:	NAME LOT A
REVIEW SET:	ADDRESS 528 EAST 7TH STR
	CITY NORTH VANCOUVER
	DRAWING TITLE: DETAILS

REVISIONS	PROJECT:
ISSUED FOR:	NAME LOT A
REVIEW SET:	ADDRESS 528 EAST 7TH STR
	CITY NORTH VANCOUVER
	DRAWING TITLE: DETAILS

REVISIONS	PROJECT:
ISSUED FOR:	NAME LOT A
REVIEW SET:	ADDRESS 528 EAST 7TH STR
	CITY NORTH VANCOUVER
	DRAWING TITLE: DETAILS



5464 PATRICIA BAY HIGHWAY,  
VICTORIA BC V8Y 2N9  
(604) 626-6020  
ROBERTBLANEYDESIGN@GMAIL.COM  
WWW.ROBERTBLANEYDESIGN.COM

REVISIONS	PROJECT:
ISSUED FOR:	NAME LOT A
REVIEW SET:	ADDRESS 528 EAST 7TH STR
	CITY NORTH VANCOUVER
	DRAWING TITLE: DETAILS

REVISIONS	PROJECT:
ISSUED FOR:	NAME LOT A
REVIEW SET:	ADDRESS 528 EAST 7TH STR
	CITY NORTH VANCOUVER
	DRAWING TITLE: DETAILS

REVISIONS	PROJECT:
ISSUED FOR:	NAME LOT A
REVIEW SET:	ADDRESS 528 EAST 7TH STR
	CITY NORTH VANCOUVER
	DRAWING TITLE: DETAILS

REVISIONS	PROJECT:
ISSUED FOR:	NAME LOT A
REVIEW SET:	ADDRESS 528 EAST 7TH STR
	CITY NORTH VANCOUVER
	DRAWING TITLE: DETAILS

REVISIONS	PROJECT:
ISSUED FOR:	NAME LOT A
REVIEW SET:	ADDRESS 528 EAST 7TH STR
	CITY NORTH VANCOUVER
	DRAWING TITLE: DETAILS

COPYRIGHT RESERVED.  
THIS DRAWING AND DESIGN ARE AND SHALL AT ALL TIMES REMAIN THE EXCLUSIVE PROPERTY OF ROBERT BLANEY DESIGN AND CANNOT BE USED OR REPRODUCED WITHOUT WRITTEN CONSENT. WRITTEN DIMENSIONS SHALL HAVE PRECEDENCE OVER SCALED DIMENSIONS. CONTRACTOR SHALL VERIFY AND SHALL BE RESPONSIBLE FOR ALL DIMENSIONS AND CONDITIONS ON THE JOB AND THIS OFFICE SHALL BE INFORMED OF ANY VARIATIONS FROM THE DIMENSIONS AND CONDITIONS AS SHOWN ON THIS DRAWING. CONTRACTORS SHALL ENSURE THAT ALL CONSTRUCTION WILL COMPLY TO ALL APPLICABLE BUILDING CODES. ROBERT BLANEY DESIGN WILL NOT ACCEPT RESPONSIBILITY FOR VARIATIONS OR MODIFICATION OF THESE PLANS.

**A109**

24X36 SCALE:	PROJECT NUMBER:
As indicated	Project Number
START DATE:	

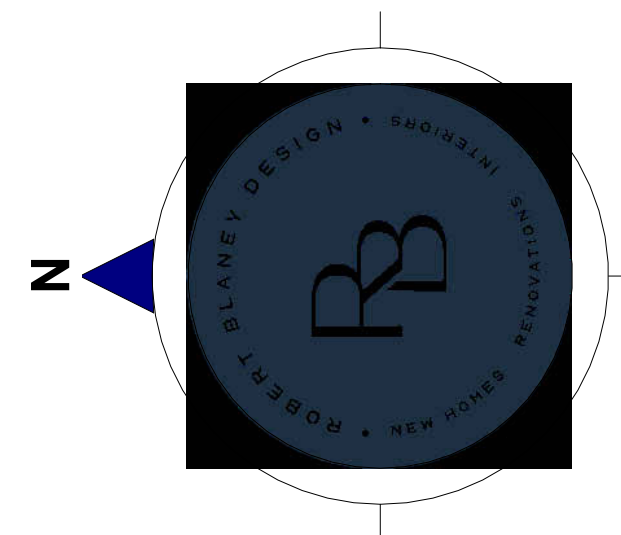

Area Schedule (Gross Building)			
Name	Area	Level	Perimeter
MAIN FLOOR	908 ft <sup>2</sup>	MAIN FLOOR	143'-6"
BASEMENT	1075 ft <sup>2</sup>	BASEMENT	160'-6"
2ND FLOOR	833 ft <sup>2</sup>	2ND FLOOR	140'-9 1/2"
GARAGE	250 ft <sup>2</sup>	GARAGE T.O SLAB	65'-6"
	3067 ft <sup>2</sup>		

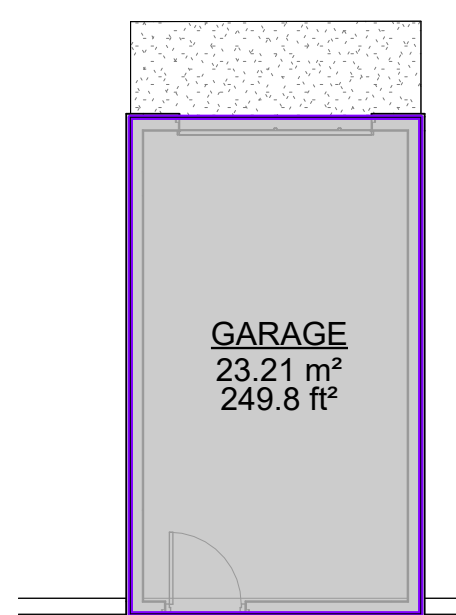

GARAGE  
23.21 m<sup>2</sup>  
249.8 ft<sup>2</sup>

**4 GARAGE**  
1/8" = 1'-0"

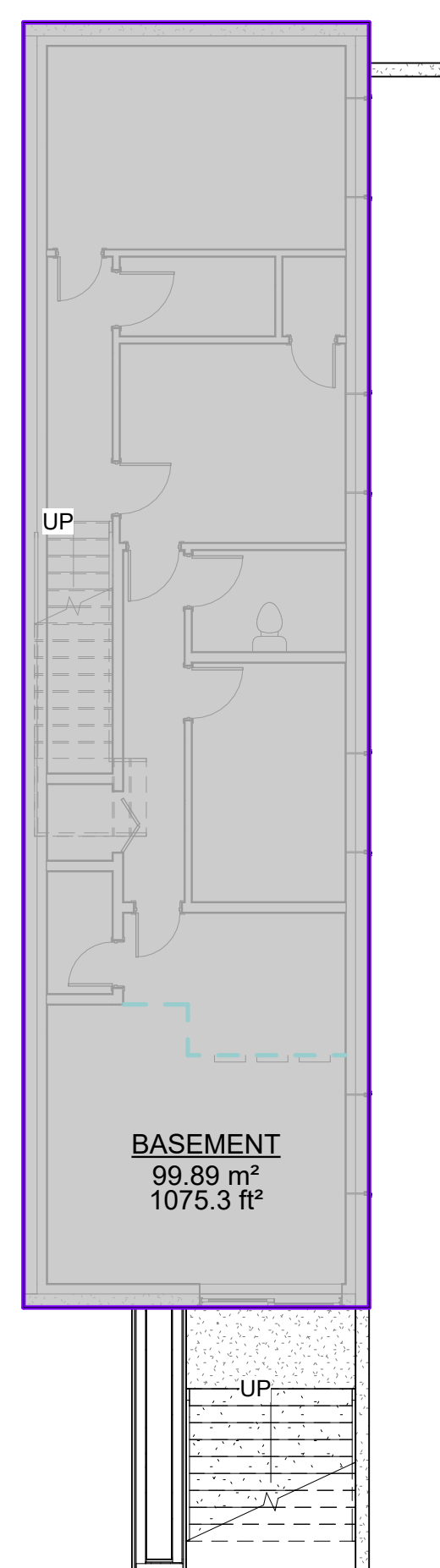

BASEMENT  
99.89 m<sup>2</sup>  
1075.3 ft<sup>2</sup>

**3 BASEMENT**  
1/8" = 1'-0"

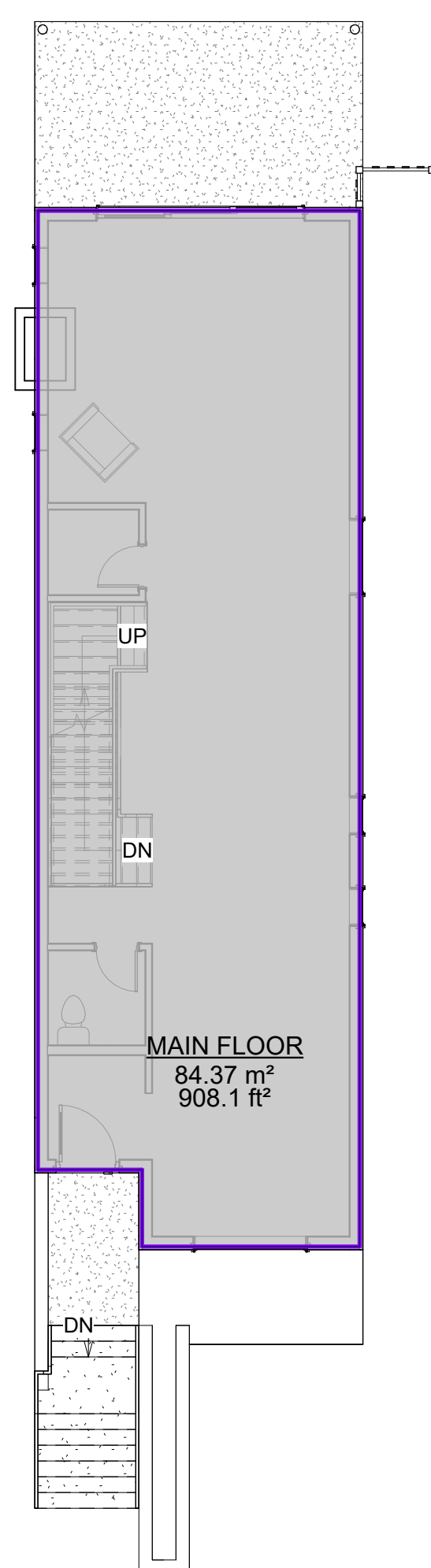

MAIN FLOOR  
84.37 m<sup>2</sup>  
908.1 ft<sup>2</sup>

**1 MAIN FLOOR**  
1/8" = 1'-0"

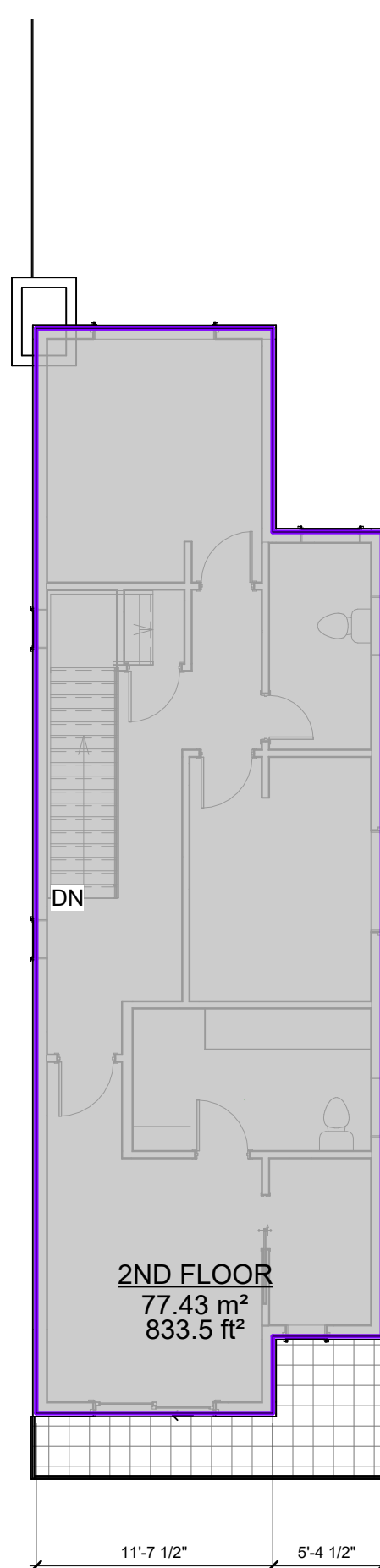

2ND FLOOR  
77.43 m<sup>2</sup>  
833.5 ft<sup>2</sup>

**2 2ND FLOOR**  
1/8" = 1'-0"

REVISIONS  
ISSUED FOR:  
REVIEW SET: 08/11/22

PROJECT:  
NAME LOT A  
ADDRESS 528 EAST 7TH STR  
CITY NORTH VANCOUVER

SHEET:

**A110**

DRAWN BY: SDP

24X36 SCALE:  
1/8" = 1'-0"

PROJECT NUMBER:  
Project Number

START DATE:

COPYRIGHT RESERVED.

THIS DRAWING AND DESIGN ARE AND SHALL AT ALL TIMES REMAIN THE EXCLUSIVE PROPERTY OF ROBERT BLANEY DESIGN AND CANNOT BE USED OR REPRODUCED WITHOUT WRITTEN CONSENT. WRITTEN DIMENSIONS SHALL HAVE PRECEDENCE OVER SCALED DIMENSIONS. CONTRACTOR SHALL VERIFY AND SHALL BE RESPONSIBLE FOR ALL DIMENSIONS AND CONDITIONS ON THE JOB AND THIS OFFICE SHALL BE INFORMED OF ANY VARIATIONS FROM THE DIMENSIONS AND CONDITIONS AS SHOWN ON THIS DRAWING. CONTRACTORS SHALL ENSURE THAT ALL CONSTRUCTION WILL COMPLY TO ALL APPLICABLE BUILDING CODES. ROBERT BLANEY DESIGN WILL NOT ACCEPT RESPONSIBILITY FOR VARIATIONS OR MODIFICATION OF THESE PLANS.

ROBERT BLANEY  
HOMES



5464 PATRICIA BAY HIGHWAY,  
VICTORIA BC V8Y 2N9  
(604) 626-6020  
ROBERTBLANEYDESIGN@GMAIL.COM  
WWW.ROBERTBLANEYDESIGN.COM

DRAWING TITLE:  
F.A.R

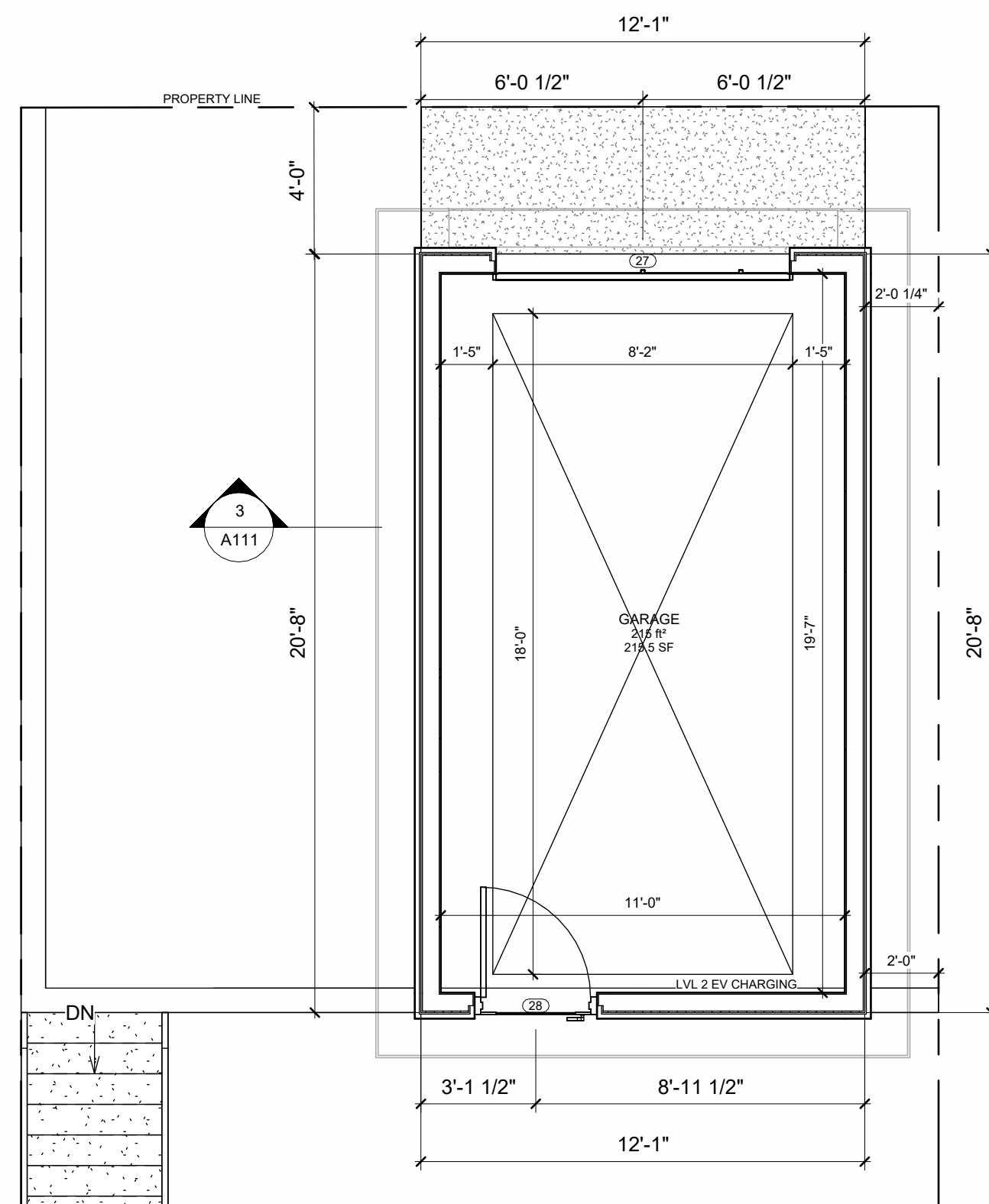

**1 GARAGE FLOOR PLAN**  
1/4" = 1'-0"

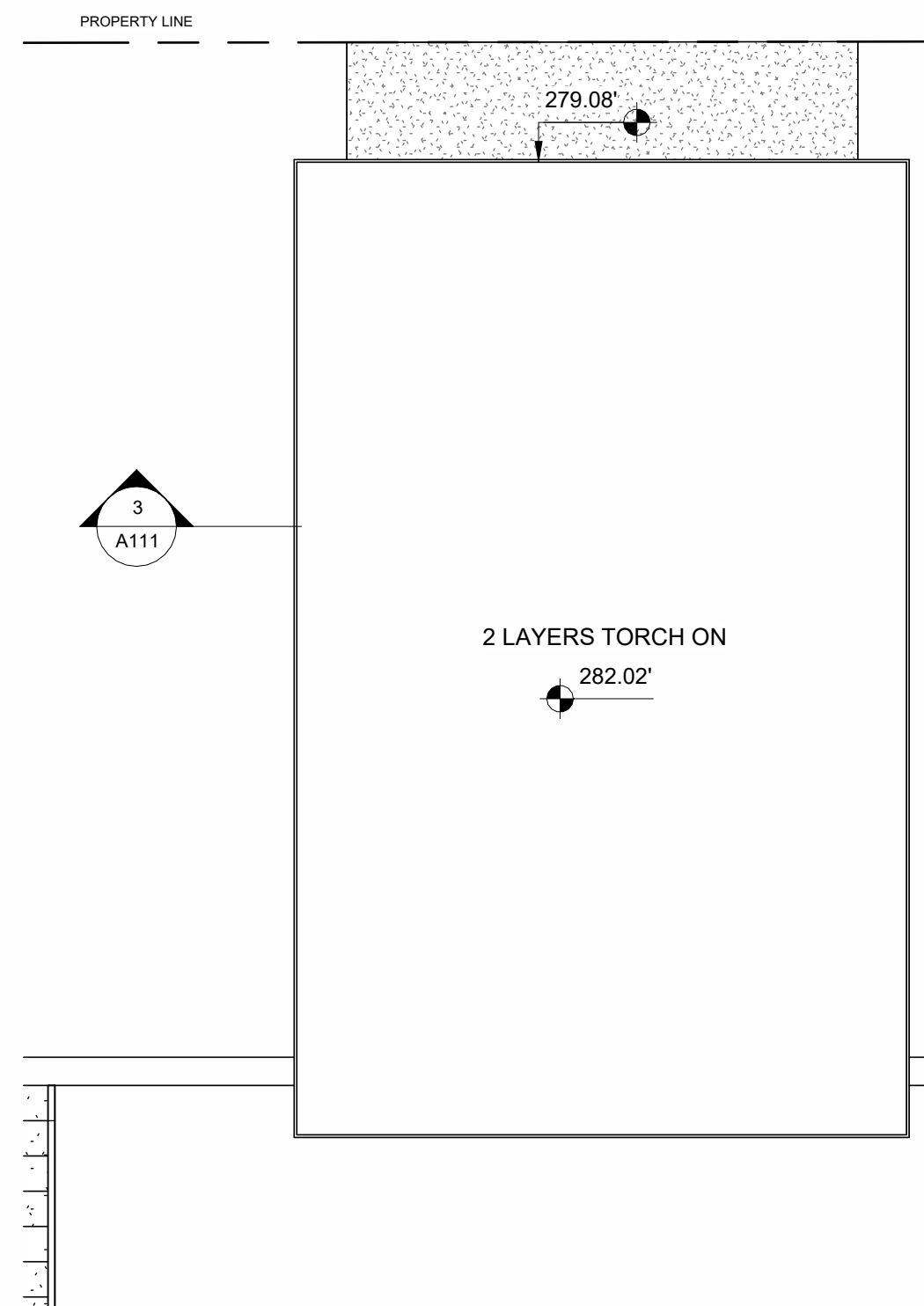

**2 GARAGE ROOF PLAN**  
1/4" = 1'-0"

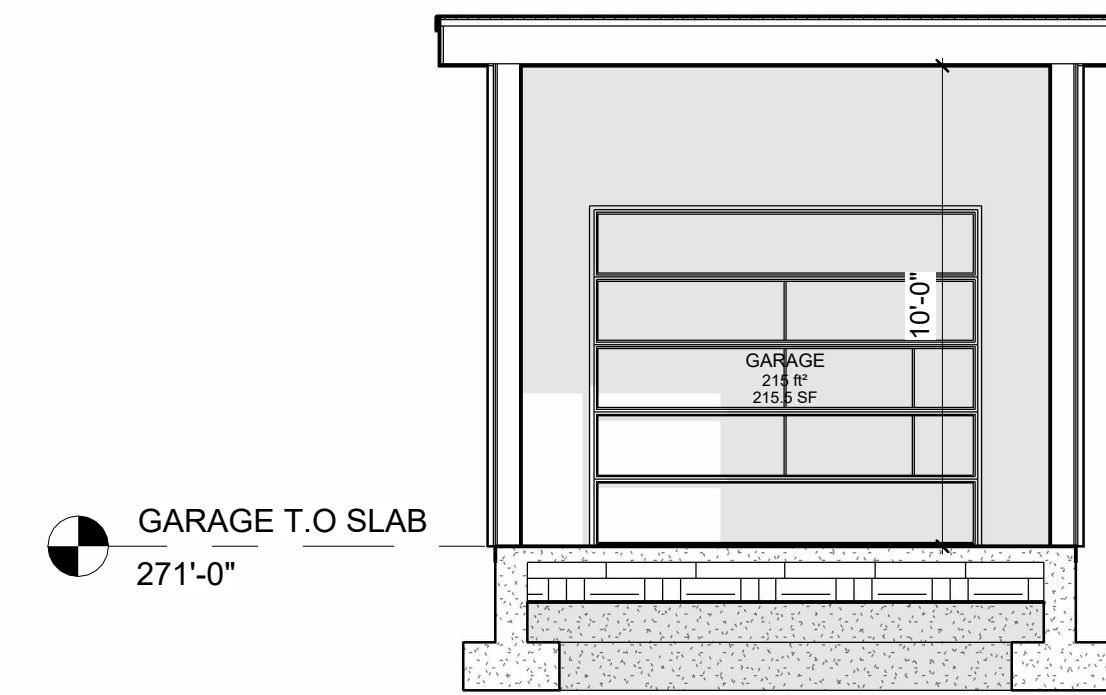

**3 GARAGE SECTION**  
1/4" = 1'-0"

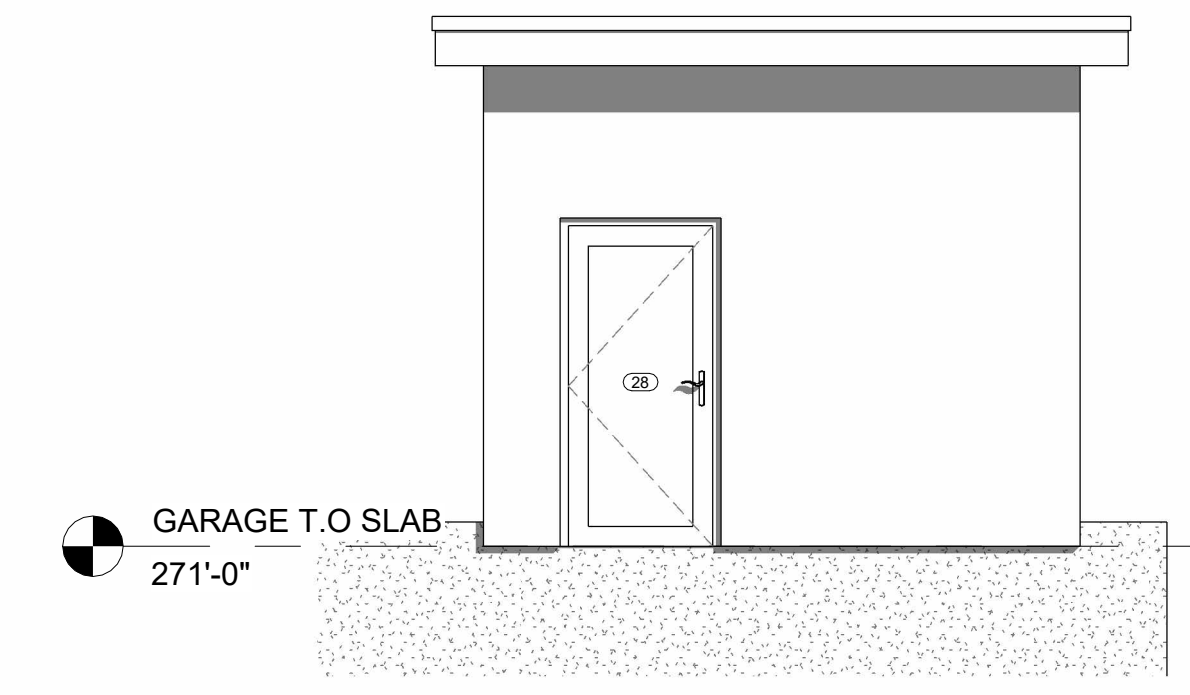

**6 GARAGE - SOUTH**  
1/4" = 1'-0"

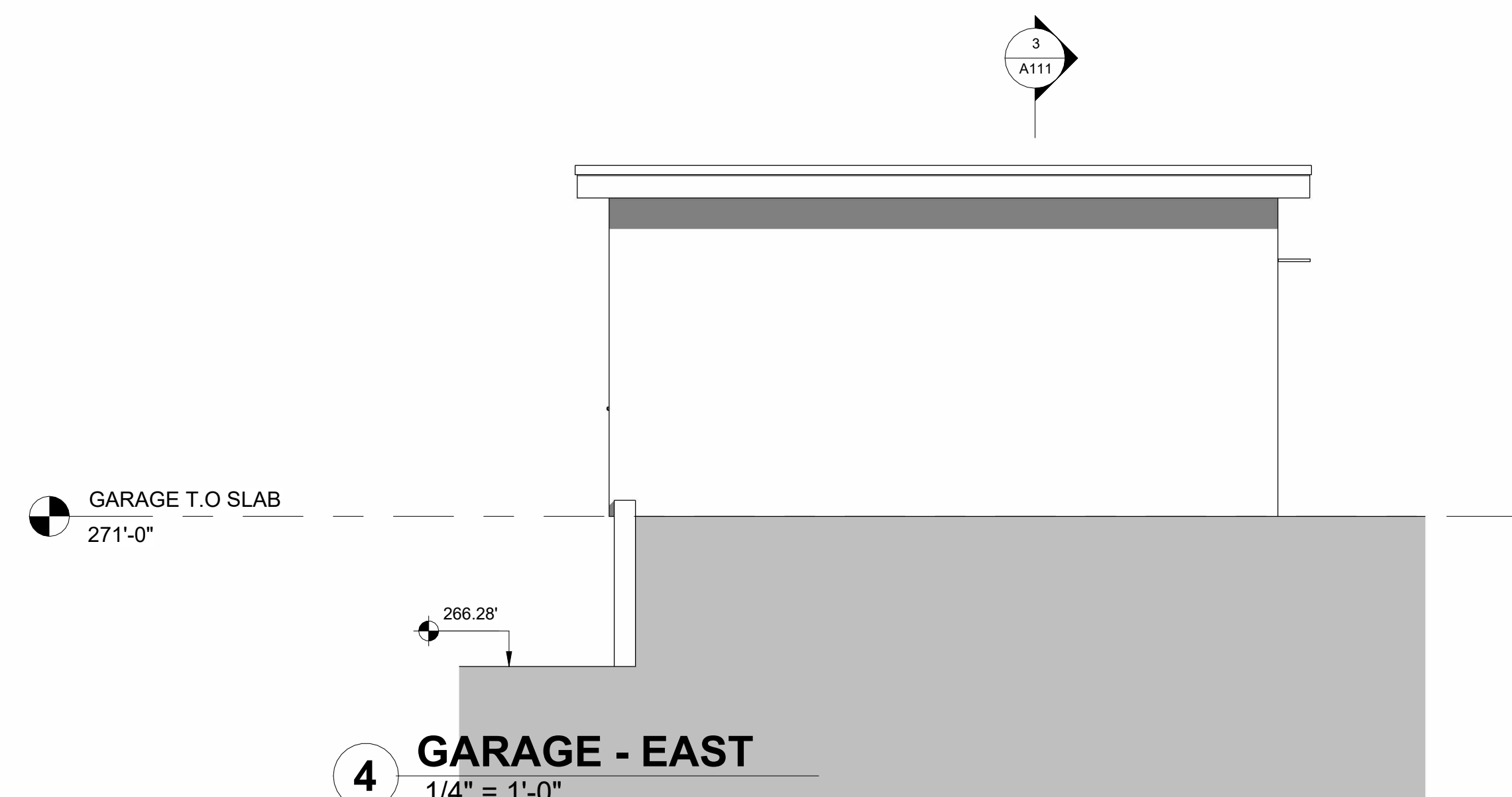

**4 GARAGE - EAST**  
1/4" = 1'-0"



**5 GARAGE - NORTH**  
1/4" = 1'-0"

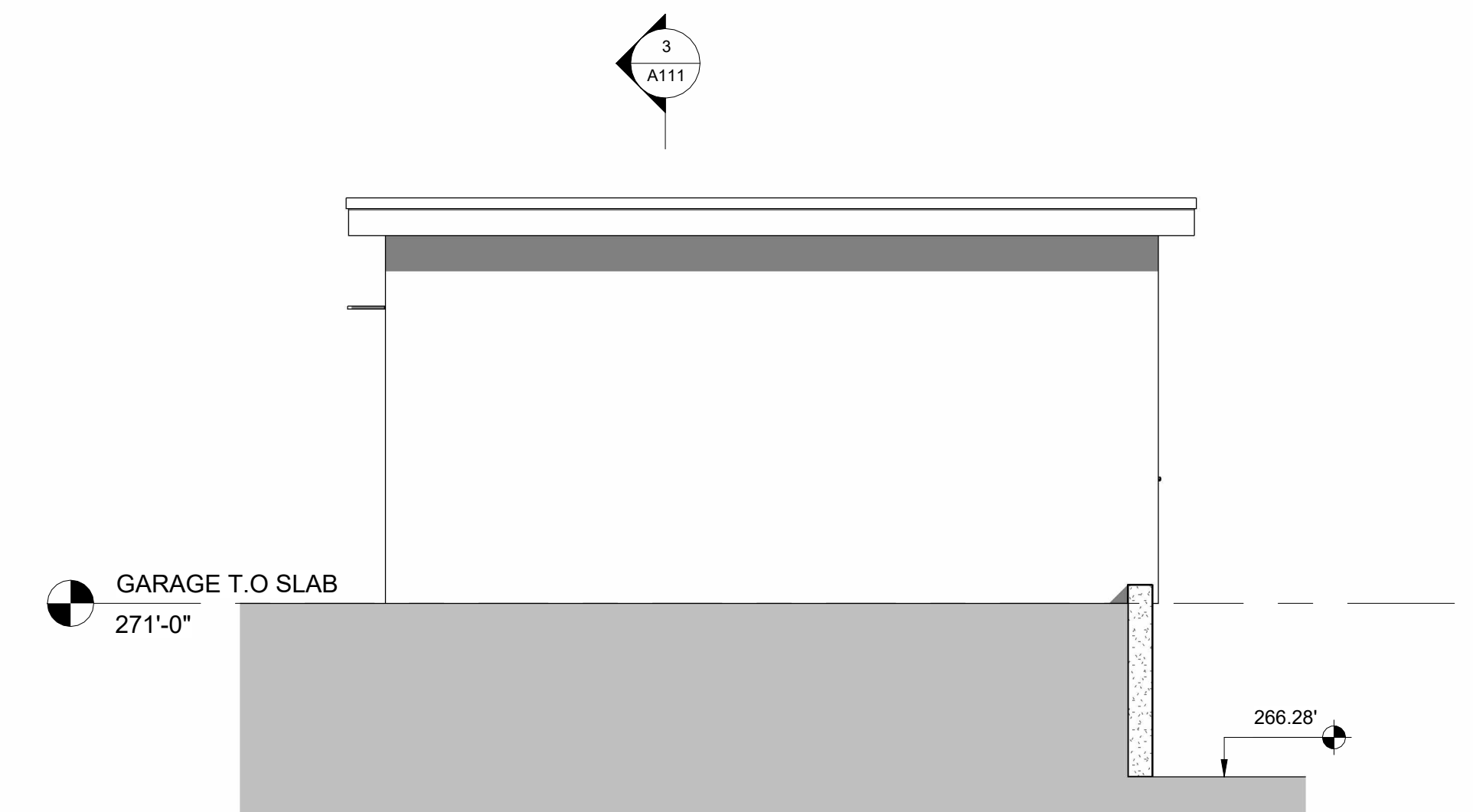

**7 GARAGE - WEST**  
1/4" = 1'-0"