



LA

ALCUIN COLLEGE
63 MAHON AVENUE

DESIGN BRIEF
ADVISORY DESIGN PANEL
CITY OF NORTH VANCOUVER

OCTOBER 21, 2020

DESIGN BRIEF - ALCUIN COLLEGE - 10/21/20

PROJECT TEAM

ARCHITECTURE	LAMOUREUX ARCHITECT INC.
CIVIL	CREUS
LANDSCAPE	CONNECT LANDSCAPE ARCHITECTURE
ENVELOPE	BAMTEC
GEOTECHNICAL	GEOPACIFIC
STRUCTURAL	WICKE HERFST MAVER
ELECTRICAL	EMEC
MECHANICAL	EMEC
CODE	MR CONSULTING
LIGHTING	MARGOT RICHARDS LIGHTING
ENERGY	MURI CONSULTING GROUP INC.

TABLE OF CONTENTS

1.0	RATIONALE	
1.1	DESIGN	1
1.2	SUSTAINABILITY	3
1.3	CPTED	4
1.4	4 TH STOREY ADDITION	5
2.0	CONTEXT	
2.1	AERIAL VIEW	8
2.2	CONTEXT MAP	9
2.3	SHADOW STUDY	10
2.4	SITE VIEWS	11
2.5	VIEW STUDY	12
2.5	CONTEXT ELEVATIONS	13
3.0	PLANNING	
3.1	AREA SUMMARY	16
3.2	PARKING SUMMARY	17
3.3	ZONING	18
4.0	DESIGN	
4.1	MATERIAL SAMPLE	19
4.2	BUILDING ELEVATIONS	20
4.3	SITE PLAN	24
4.4	BUILDING PLANS	25
4.5	BUILDING SECTIONS	31
5.0	LANDSCAPE	
5.1	RENDERED PLANS	33
5.2	GRADING	37
5.3	PLANTING PLANS	38
5.4	IRRIGATION PLAN	40
5.5	DETAILS	42



THE SCHOOL'S PHILOSOPHY

St Alcuin College for the Liberal Arts (the 'School') is an independent, non-denominational university-preparatory school in North Vancouver, British Columbia. Its mission is to provide each student with a rich, rigorous and personalized education in an intimate setting. The goal is to foster creativity and achievement. The new proposed location for the School leverages an urban setting in order to provide students with this rich educational experience.

LOCATION

The new school is located in excellent proximity to existing transportation networks, the Lower Lonsdale community and associated amenities. Furthermore, the addition of Alcuin College adjacent to the new Polygon site reinforces the City of North Vancouver's desire and commitment to support institutional and public amenity uses along this corridor. The project is located just west of the newly constructed Polygon mixed-use site and is designed to connect to the street edge and appropriately punctuate the end of West Esplanade. It is the intention that the building and surrounding proposed landscaping will offer an alternate and pleasant route for pedestrians looking to connect to Lower Lonsdale via 1st Street and Mahon Avenue. Currently under construction directly to the north and across a laneway is a 6-storey mixed use residential project.

THE SITE

The irregular and steeply sloped site posed several challenges; however, the particulars of the site have been treated as an asset. The building orientation carefully considers views, sun exposure, and addresses two streets of very different characters - Forbes, a busy thoroughfare to the west and Mahon, a quiet residential cul-de-sac to the east.

THE BUILDING

The application proposes a new approximately 3033 square meter 4-storey building to house a private K-12 school on a site previously occupied by an auto repair shop. The 4th storey of the project is designed as a jointly operated community event amenity space that is made possible by Alcuin's parent participant development partner, Montaigne Group Ltd. The proposed FAR is 2.6 at 82% site coverage with the 3rd floor limited to 1/3 of the floor plate in lieu of a roof garden. The roof line is limited to 21.2 meters (69.47 feet) above average grade. The distinctive building is designed to take full advantage of the remarkable views from a quieter street by orienting much of its glazing on Mahon Avenue with the intent to engage with a quieter, more human-scaled residential street. In order to further enhance the public realm on Mahon, the building sets back from the street at the ground level to allow for a generous landscaped buffer, a covered entrance and seating at the school's entrance to offer a vibrant street life.



At the 3rd floor, a planted outdoor terrace is proposed as a learning space as well as an urban oasis for both teachers and staff. It is intended that some classes will be taught here in the summer months. The garden will also serve as a hands-on urban garden teaching tool as well as a beautiful peaceful place for teachers and students to have lunch, read a book or converse with friends. A green wall screen will provide privacy for rooftop patio activities but will also provide greenery for residents of neighbouring buildings and help buffer any excess noise that may come from any rooftop activities. The building form steps down towards Esplanade Avenue and away from the larger mass of the new Polygon development to the east, reducing impact on the existing area. The 4th floor which houses the event space presents a dramatic and dynamic architectural image, with a form that expands towards the panoramic south-west views.

STORM WATER STRATEGY

With the zoning for the Alcuin College project changing from Industrial to Institutional, the R value is being reduced from 0.85 to 0.80. As the run-off coefficient is being reduced, we don't anticipate any requirement for reduction of stormwater volume from the site. To prevent flooding, we have included an overflow orifice which will drain to the storm sewer.

LANDSCAPE

The landscape design for Alcuin College provides a modern and streamlined series of spaces that are tailored to the teaching style of the school. A tough, low-maintenance strategy, with durable materials is balanced with an attractive aesthetic that establishes an inviting and attractive series of spaces for student use. These principles will create an attractive setting for the school at the ground level, and a useful and attractive setting for the roof level learning areas. The primary drop-off area is located in close proximity to the main entrance facilitates student arrival and departures. It is supported with a generous, covered seating/waiting space and covered bicycle parking. A terraced hardscape at the east side entrance works with the sloping grades. At the south end of the building, this terracing of hard and soft landscaping terminates into a rain garden that can help manage storm water from Mahon Avenue. A dedication along Forbes Avenue will support improved pedestrian and cycling infrastructure.

The roof level area provides a series of spaces that relate to interior functions. Large amounts of seating edges will support the numbers of students anticipated. Raised metal planters will provide urban agricultural and educational opportunities and allow for small trees to provide some shading and structure to the spaces. These planters, along with additional green roof style buffer plantings where suitable, incorporate a level of green vegetation while maintaining large functional spaces. An elevated platform will supply informal seating along



its edges, as well as creating a stage venue for outdoor presentations and performances. Along the east edge of the roof terrace, a vertical trellis will support climbing vines and create a green “screen” offering privacy and visual interest to and from the neighbouring residential block. Variations in paving material choices help to define further the different spaces and functions. Clean and simple materials are fitted to the style of the architecture and help reduce maintenance. Movable furniture will allow for flexible seating configurations that can quickly and easily adapt to different school uses, from casual lunch-time seating to more formal classroom-style arrangements or school performances on the raised stage platform. Detailing for landscape elements will look to the architectural forms for inspiration as plans develop. Plant materials are selected based on native and adaptive, low-maintenance and highly attractive characteristics, with low water requirements. All of these components, along with thoughtful lighting, will maximize the year-round usability of the outdoor spaces, and support the school's learning philosophy.

SITE + BUILDING ORIENTATION

The project is located in the dense Lower Lonsdale area. The location is highly accessible by transit, bicycle networks, and walkable sidewalks to promote alternative modes of transportation. The project site is currently vacant and once developed will become part of the vibrant urban streetscape and bring more activity to the Lower Lonsdale community.

The unique triangular shape of the building focuses views to the South and Southwest. Glazing on the east side brings in morning light while the punched window patterns on the South and West facades provide opportunities to mitigate undesirable heat gains during the warmer summer months with solar shading. The setback third level patio reveals an open rooftop deck that breaks up the massing of the building and provides an opportunity for outdoor learning and entertainment on site. The fourth storey cantilevers over the rooftop patio providing shade and protection during inclement weather; extending the use of the outdoor space throughout the year. The outdoor patio focuses views again to the South and West and to increase privacy and mitigate noise from outdoor activities there will be a green wall screen on the East side of the rooftop.

ENERGY + MATERIALS

The energy efficiency target for the project is to confirm with 14% or better energy cost savings following Section 11 – Energy Cost Budget Method of ASHRAE 90.1-2016 compliance path. Heating will be provided by in-slab radiant heating system served by the Lonsdale Energy Centre (LEC) and cooling will be by variable refrigerant drive outdoor and indoor fancoil units. These systems will create a comfortable learning environment in the building and help keep operation costs low. Initial energy modeling suggests that the project should substantially exceed the required 14% energy cost savings by upward of an additional 10%.



DESIGN BRIEF - ALQUIN COLLEGE - FALL 2020

The project team will make an effort to source local, responsible, and healthy materials whenever possible and will use programs such as LEED and WELL Building Standard as a guide. Providing a quality learning environment is of utmost importance therefore choosing healthy materials for the interior finish will be critical.

SOCIAL + CULTURAL BENEFITS

Throughout the day the school will support up to 200 students and staff. The students will increase circulation and activity in and around the site creating a more vibrant site. During the evenings and weekends the fourth storey event space is able to support gatherings for up to 150 people. The usage of these two spaces at maximum capacity will not occur simultaneously. The space has been offered free of charge for periodic use to community groups such as North Shore Community Resource Society, Big Brother/Big Sisters, Scouts/Girl Guides. The space has also been offered for free of charge for periodic use to the Squamish First Nation for cultural meetings or community functions.

CRIME PREVENTION THROUGH ENVIRONMENTAL DESIGN (CPTED)

Alcuin College has been designed with the safety of students and the community in mind. The building and its architectural features will revitalize a currently underutilized corner of the Lower Lonsdale community and help minimize the fear of crime in the area. The newly constructed neighbouring residential developments in the area along Mahon and W 1st street also help keep the area active and well supervised. Mahon Avenue and Esplanade are popular routes for vehicle, bicycle, and pedestrian traffic which also helps increase supervision and eyes on the street.

There is currently ample street lighting in the area that has been updated or installed with the construction of new residential developments. At grade this development will further enhance the streetlight network along Mahon and help illuminate the dark corner of Forbes and Esplanade. Additional lighting will also be provided in the shared laneway.

The main entrance is located in clear view on Mahon Avenue. The glazing at grade on the east side of the building provides daylight to the main level classrooms and a visible connection to the street. Interior lighting will help illuminate the sidewalk and bike parking area with the help of exterior lighting under the overhang of level 2. The main entrance is the primary access point for people coming into the building. Entrants are welcomed by Alcuin staff at Reception before gaining access to the secure areas of the school. The parkade and garbage collection room are only accessible through a security gate at the bottom of the ramp that descends from Mahon. The service entrance in the laneway is a secondary access point used only for loading and unloading during special events. This access point is secure, clearly visible, and well lit to provide a safe environment at night.

Exit stairs provide access to exit doors at grade along Mahon. These stair corridors support long windows that bring daylight into the stair and provide a visual connection to the street. Exits to outside are clearly visible and well lit. The “punched” windows away from the main entrance in the laneway and along Forbes and Esplanade are elevated at least 7’ above the street to prevent damage and graffiti. These windows still allow for daylight into the school and allow for eyes on the street from above.

Glass is used extensively at grade on the east side of the building near the entrance. It is durable, damage resistant, and easily cleaner. Dark metal panels clad the lower parts of the building. Below grade there is sealed concrete which is also durable and damage resistant.



2.1

CONTEXT AERIAL VIEW

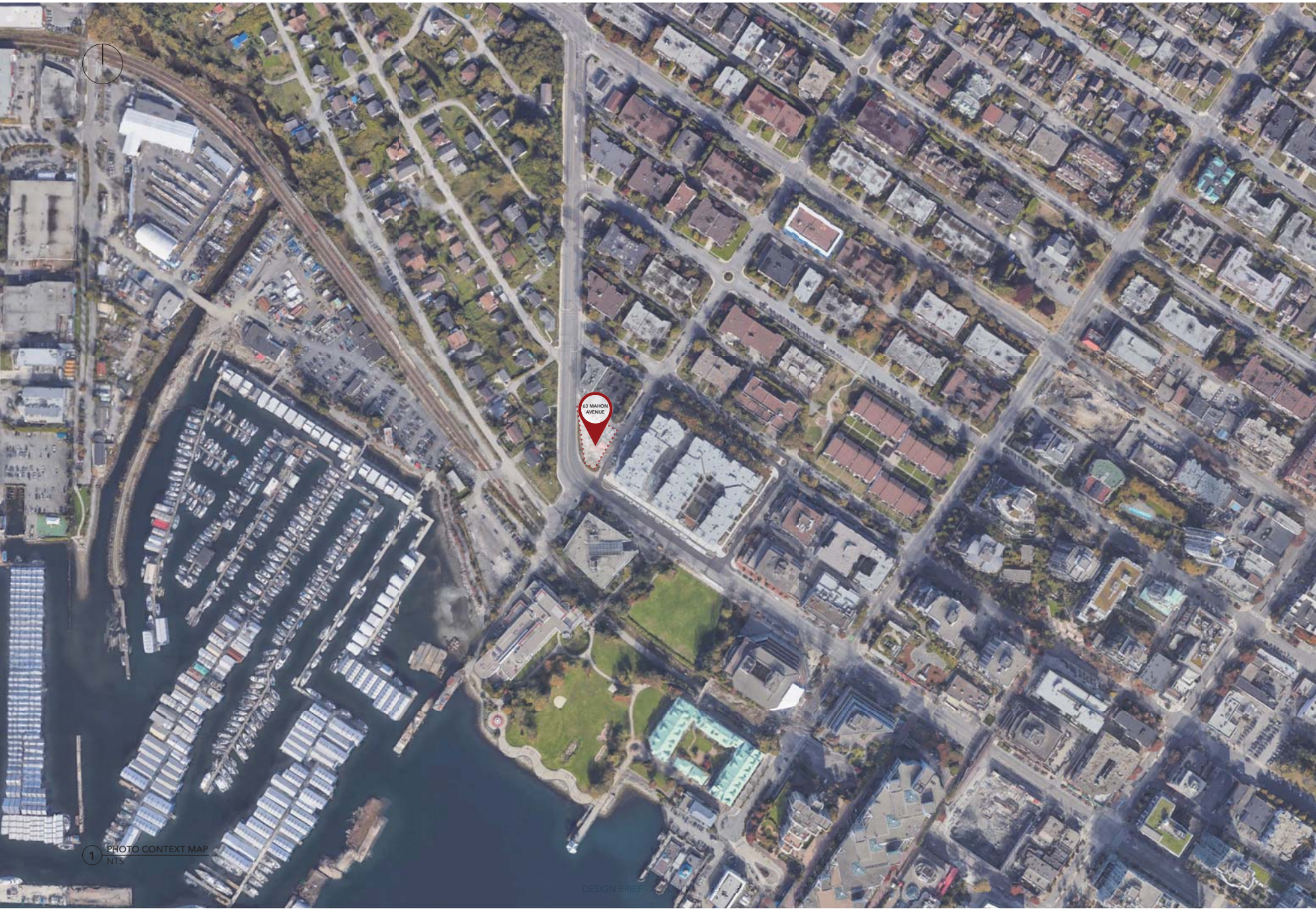



2.2

CONTEXT CONTEXT MAP

1 CONTEXT PLAN
1/32" = 1'-0"

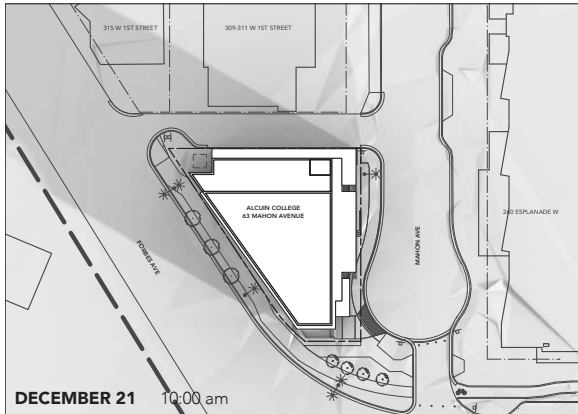

DECEMBER 21 10:00 am

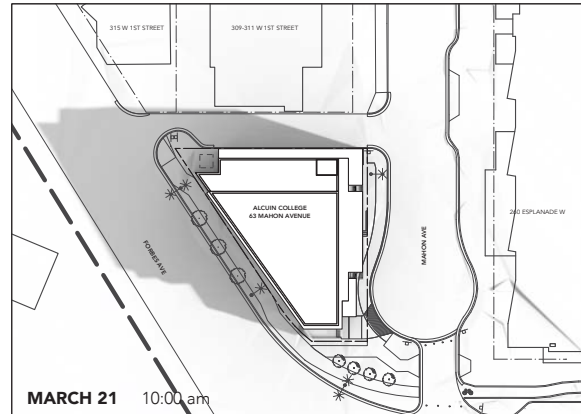

MARCH 21 10:00 am

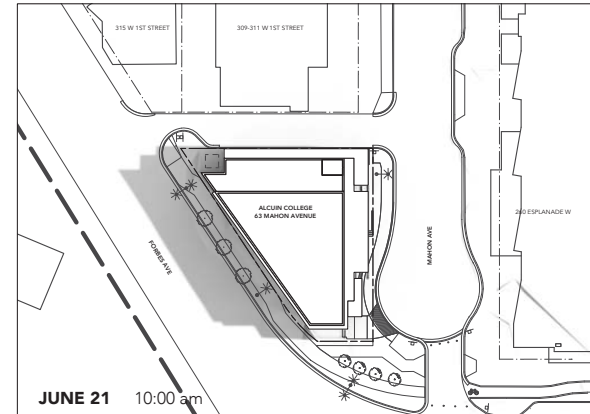

JUNE 21 10:00 am

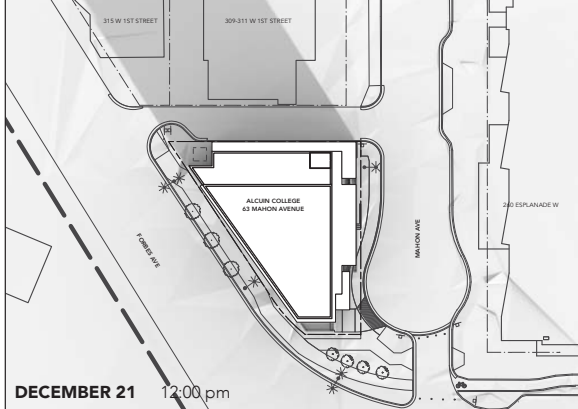

DECEMBER 21 12:00 pm

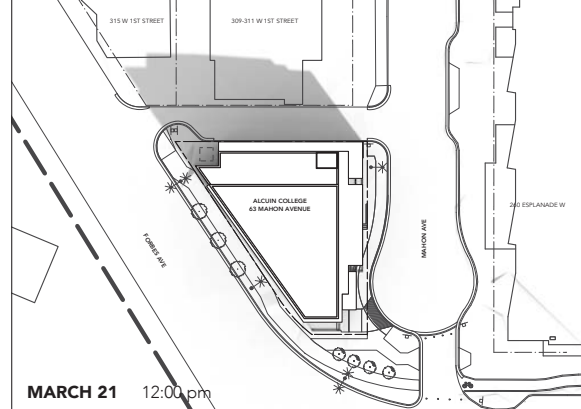

MARCH 21 12:00 pm

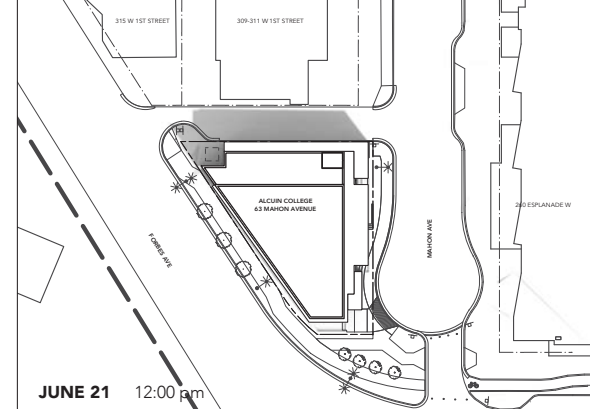

JUNE 21 12:00 pm

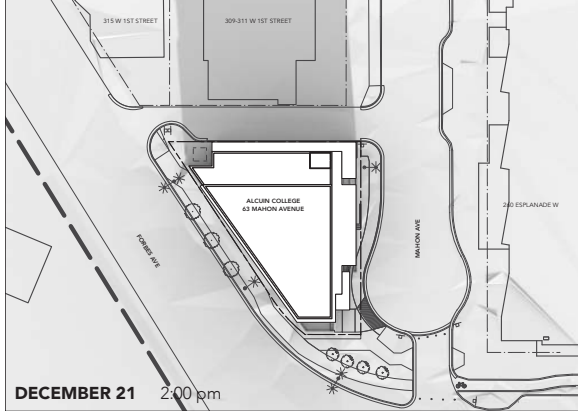

DECEMBER 21 2:00 pm

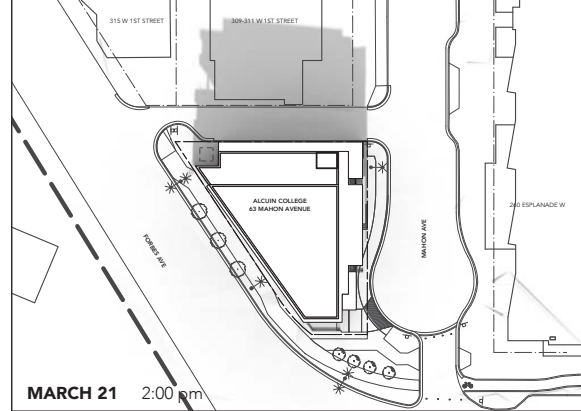

MARCH 21 2:00 pm

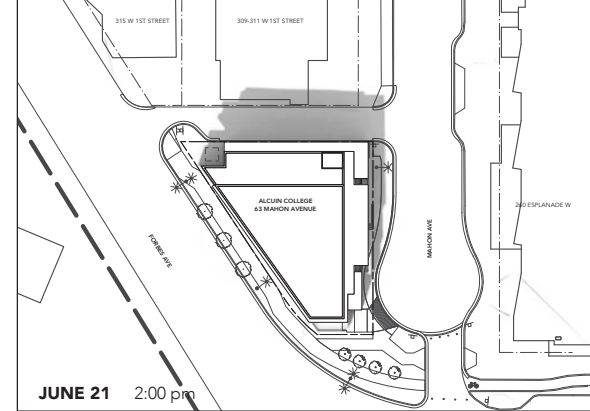

JUNE 21 2:00 pm

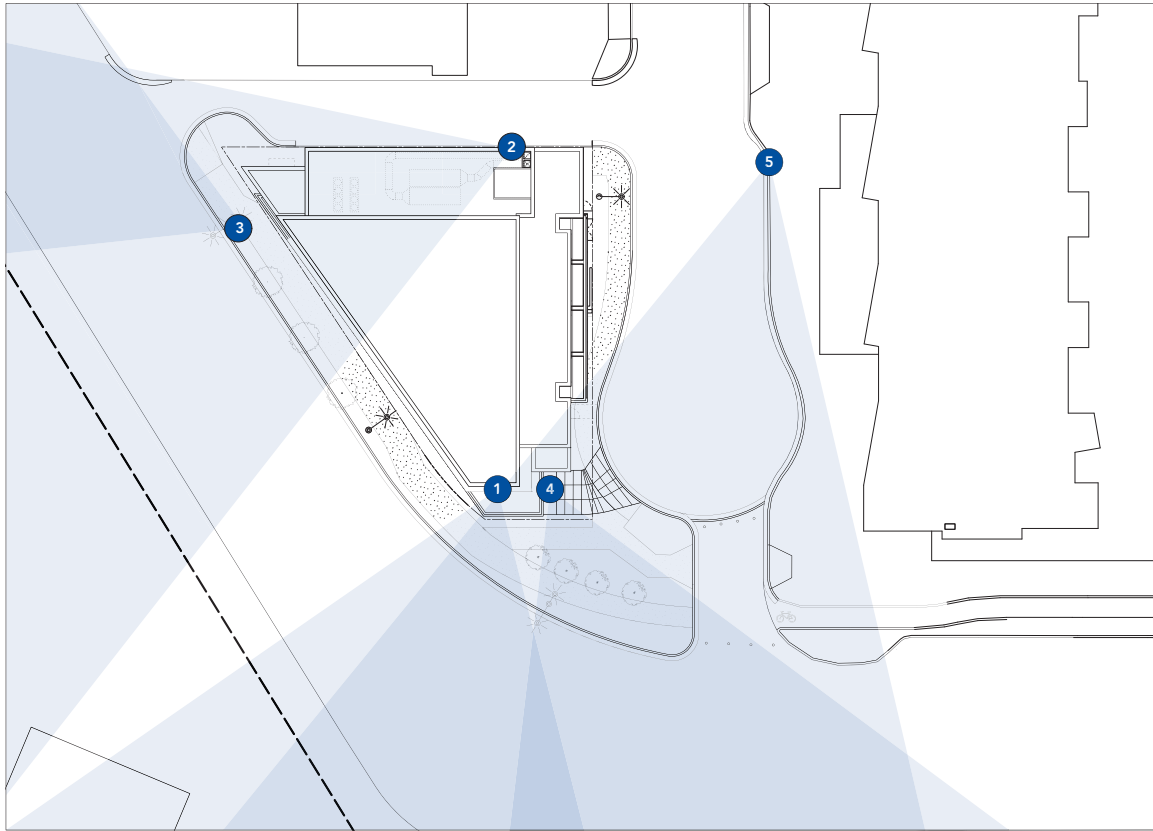

ALCUIR COLLEGE (H STOREY) - DEVELOPMENT PERMIT SUBMISSION - CITY OF NORTH VANCOUVER - SUMMER 2020

— PREVIOUS DESIGN (PRESENTED SEPTEMBER 16, 2020)
— REVISED DESIGN (CURRENT AS OF OCTOBER 21, 2020)

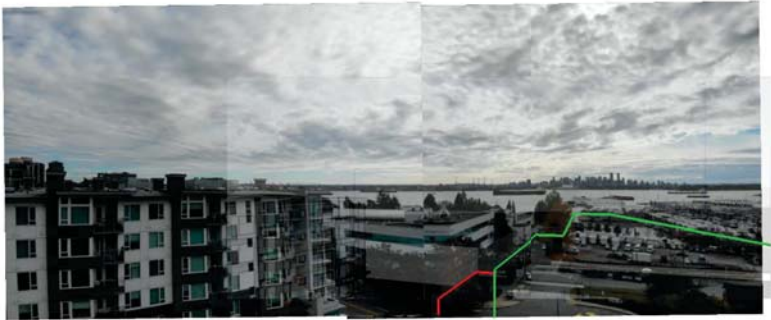

PENTHOUSE



6TH FLOOR

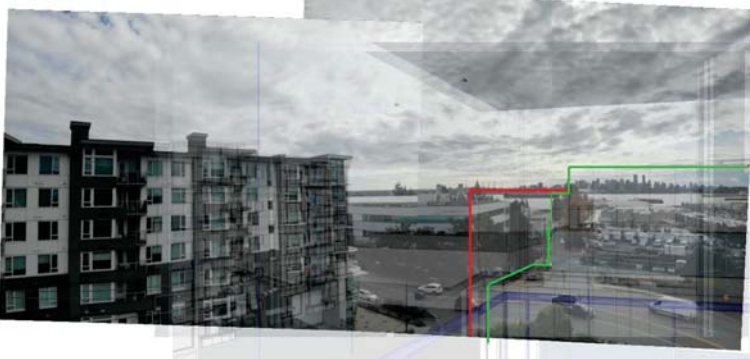

5TH FLOOR





ESPLANADE W

PROPOSED
63 MAHON AVE

LANEWAY

309-311 W 1ST STREET

W 1ST STREET

1 EAST CONTEXT ELEVATION (MAHON AVE)
1/32" = 1'-0"



VANCOUVER
HARBOUR

ESPLANADE W

FORBES AVE

W 1ST STREET

MAHON AVE

MAHON AVE

2ND ST W

2ND ST W

3RD ST W

3RD ST W



FORBES AVE

PROPOSED
63 MAHON AVE

MAHON AVE

260 ESPLANADE W

1 SOUTH CONTEXT ELEVATION (ESPLANADE)
1/32" = 1'-0"





W 1ST STREET

309-311 W 1ST STREET

LANEWAY

PROPOSED
63 MAHON AVE

ESPLANADE W

① SOUTH WEST CONTEXT ELEVATION (FORBES AVE)
1/32" = 1'-0"



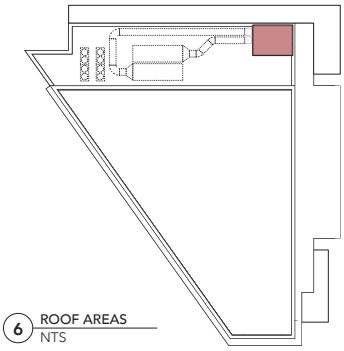

6 ROOF AREAS
NTS

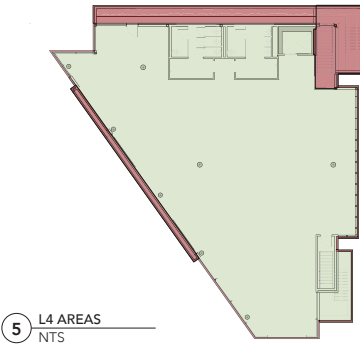

5 L4 AREAS
NTS

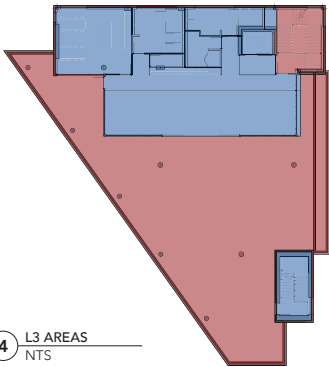

4 L3 AREAS
NTS

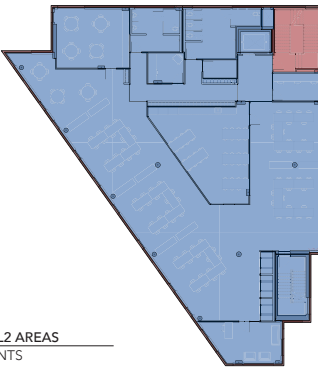

3 L2 AREAS
NTS

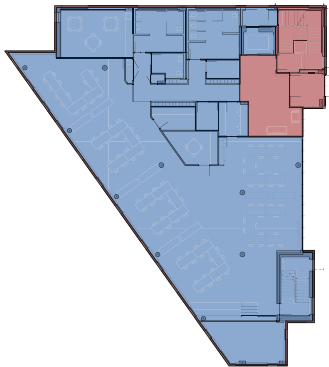

2 L1 AREAS
NTS

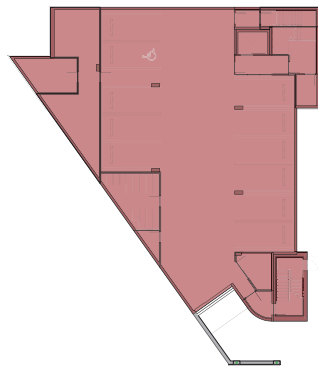

1 P1 AREAS
NTS

AREA SUMMARY

SITE	TOTAL AREA			
	SF		SM	
TOTAL	7927.66		736.50	

PARKADE	GFA		EXCLUSION		NET AREA	
	SF	SM	SF	SM	SF	SM
PARKING	4120.05	382.77	4120.05	382.77	0.00	0.00
MECHANICAL	915.57	85.06	915.57	85.06	0.00	0.00
STORAGE	218.02	20.25	218.02	20.25	0.00	0.00
CIRCULATION	596.83	55.45	596.83	55.45	0.00	0.00
TOTAL PARKADE	5850.46	543.53	5850.46	543.53	0.00	0.00

LEVEL 1	GFA		EXCLUSION		NET AREA	
	SF	SM	SF	SM	SF	SM
LOBBY + VESTIBULE	475.85	44.21	475.85	44.21	0.00	0.00
ALCUIN	5624.42	522.53	0.00	0.00	5624.42	522.53
STAIR 1	278.92	25.91	279.68	25.98	-0.76	-0.07
WALL	144.44	13.42	144.44	13.42	0.00	0.00
TOTAL LEVEL 1	6523.62	606.06	899.96	83.61	5623.66	522.45

LEVEL 2	GFA		EXCLUSION		NET AREA	
	SF	SM	SF	SM	SF	SM
ALCUIN	6468.61	600.95	0.00	0.00	6468.61	600.95
STAIR 1	286.55	26.62	286.55	26.62	0.00	0.00
WALL	145.20	13.49	145.20	13.49	0.00	0.00
TOTAL LEVEL 2	6900.37	641.06	431.76	40.11	6468.61	600.95

LEVEL 3	GFA		EXCLUSION		NET AREA	
	SF	SM	SF	SM	SF	SM
ALCUIN	2656.50	246.80	0.00	0.00	2656.50	246.80
ROOFTOP AMENITY	3864.52	359.03	3863.98	358.98	0.53	0.05
STAIR 1	287.16	26.68	289.52	26.90	-2.36	-0.22
WALL	92.96	8.64	92.96	8.64	0.00	0.00
TOTAL LEVEL 3	6901.13	641.14	4246.46	394.51	2654.67	246.63

LEVEL 4	GFA		EXCLUSION		NET AREA	
	SF	SM	SF	SM	SF	SM
HAVAAL	5514.14	512.28	0.00	0.00	5514.14	512.28
STAIR 1	338.67	31.46	284.11	26.39	54.56	5.07
PATIO	483.16	44.89	483.16	44.89	0.00	0.00
WALL	117.72	10.94	117.72	10.94	0.00	0.00
TOTAL LEVEL 4	6453.69	599.57	884.99	71.28	5568.70	517.35

ROOF	GFA		EXCLUSION		NET AREA	
	SF	SM	SF	SM	SF	SM
MECHANICAL	110.44	10.26	110.44	10.26	0.00	0.00
ROOF TOTAL	110.44	10.26	110.44	10.26	0.00	0.00

TOTAL DEVELOPMENT	GFA		EXCLUSION		NET AREA	
	SF	SM	SF	SM	SF	SM
TOTAL	32739.70	3041.62	12424.07	1154.23	20315.64	1887.38

SITE COVERAGE **82%** FSR **2.563**



2 ADDITIONAL PARKING NTS

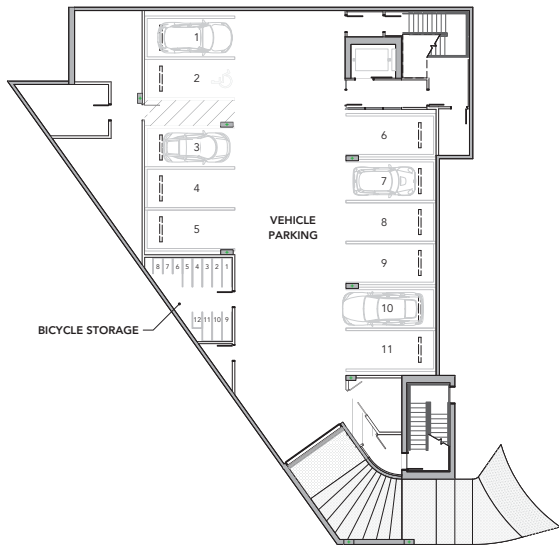

1 PARKADE LAYOUT NTS

PARKING SUMMARY						
PARKADE	PARKING SPACES					
	REQUIRED		PROPOSED			
VEHICLE PARKING	LEVEL 1-3	11	PARKADE	11		
	LEVEL 4	5	OFF-SITE	11		
TOTAL VEHICLE		16	PROPOSED	22		
BICYCLE PARKING	LEVEL 1-3	SHORT TERM	9	LEVEL 1-3	SHORT TERM	9
		SECURE	6		SECURE	11
	LEVEL 4	SHORT TERM	7	LEVEL 4	SHORT TERM	7
		SECURE	2		SECURE	2
TOTAL BICYCLE		REQUIRED	24	PROPOSED	29	

PARKING

The current parkade design supports 11 vehicle parking stalls including 10 standard stalls and 1 accessible stall. This is in alignment with the current provisions outlined in the CD 684 Zone. The parkade is a secure controlled access area and the 11 spots will be used primarily during the day by Alcuin staff. To support the 4th storey and any additional parking requirements from the school an additional 11 parking spaces have been acquired at 132 West Esplanade (Impark Lot 1275) approximately 450m away from Alcuin College.

The parkade also supports a secure bike storage room that offers 12 bicycle storage racks. Charging outlets for electric bicycles will be provided for a minimum of one outlet for every two bicycle stalls. Additional bicycle parking will be accommodated in the hardscaped areas near the front of the building where bicycle racks provide 16 short term bicycle parking spots.

PROJECT INFORMATION

PROJECT ADDRESS:	63 MAHON AVENUE LOWER LONSDALE NORTH VANCOUVER, BC			
PARCEL IDENTIFIER:	030-111-218			
LEGAL ADDRESS:	LOT 'D' BLOCK 161 DISTRICT LOT 271			
ZONING:	COMPREHENSIVE DEVELOPMENT 684 ZONE LOWER LONSDALE ZONE 3 (LL-3)			
OCP DESIGNATION:	MIXED USE LEVEL 4A (HIGH DENSITY)			
OWNER:	ALCUIN COLLEGE			
JURISDICTION:	CITY OF NORTH VANCOUVER			
OCCUPATION TYPE:	A-2			
CONSTRUCTION TYPE:	NON-COMBUSTIBLE			
TYPE OF WORK:	NEW CONSTRUCTION			
SCOPE OF WORK:	SECONDARY SCHOOL			
FIRE PROTECTION:	SPRINKLERED			
APPLICABLE CODES:	2018 BC BUILDING CODE, DIV B, PART 3			
NUMBER OF FLOORS:	5 STOREYS			
DENSITY:	2.56 FSR			
LOT COVERAGE:	82%			
PROPOSED SETBACKS:	FRONT (E)	REAR (N)	SIDE (W)	SIDE (S)
	1'-5 1/8"	2 5/8"	5 1/4"	10 3/8"
HEIGHT:	96'-0" [29.26 m]			
GROSS FLOOR AREAS:	PARKADE = 5850.46 SF (543.53 M2)			
	MAIN FLOOR = 6523.62 SF (606.60 M2)			
	SECOND FLOOR = 6,900.37 SF (641.06 M2)			
	THIRD FLOOR = 6,901.13 SF (641.14 M2)			
	FOURTH FLOOR = 6453.69 SF (599.57 M2)			
	TOTAL GFA = 32739.70 SF (3041.62 M2)			
	TOTAL EXCLUSIONS = 12424.07 SF (1154.23 M2)			
	TOTAL NFA = 20315.64 SF (1887.38 M2)			

NOTE: REFER TO AREA SUMMARY FOR DETAILED GFA AND FSR BREAKDOWN

ZONING AMENDMENT REQUESTS

FSR: CD-684 (3)	Increase maximum FSR from 1.2 (1.9) to 2.6 1.2 is the maximum FSR for CD-684 while 2.6 is the max FSR for LL-3
LOT COVERAGE: 6A04 (3)	Lot Coverage above second storey to exceed 35%: Level 3 Lot Coverage = 35% Level 4 Lot Coverage = 80%
BUILDING HEIGHT: 6A04 (4)	Increase Building Height to 70' Maximum Building Height for LL-3 Zone is 50'



DESIGN BRIEF - ALCUIN COLLEGE - FALL 2020



MT-01 - MEDIUM GREY METAL WALL PANEL, VERTICAL ORIENTATION, VARYING RANDOM WIDTHS
 MT-03 - MEDIUM GREY METAL WALL PANEL
 MT-07 - MEDIUM GREY PAINTED METAL WALL DOOR

ALFREX "GRAY SILVER"

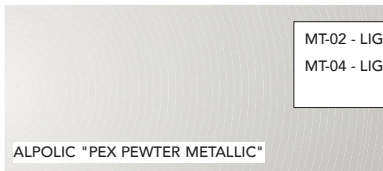

MT-02 - LIGHT GREY METAL WALL PANEL, VERTICAL ORIENTATION, VARYING RANDOM WIDTHS
 MT-04 - LIGHT GREY METAL WALL PANEL

ALPOLIC "PEX PEWTER METALLIC"

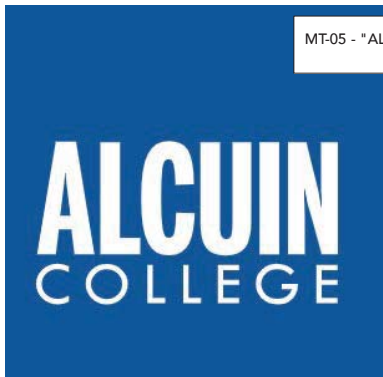

MT-05 - "ALCUIN" BLUE, METAL WALL PANEL

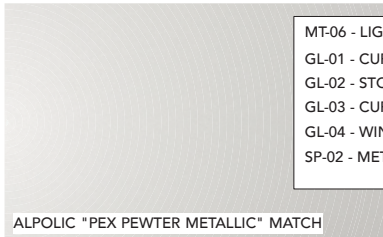

MT-06 - LIGHT GREY , METAL WALL PANEL TO MATCH LIGHT GREY "PEX PEWTER METALLIC"
 GL-01 - CURTAINWALL GLAZING, TO MATCH LIGHT GREY "PEX PEWTER METALLIC"
 GL-02 - STORE-FRONT GLAZING, TO MATCH LIGHT GREY "PEX PEWTER METALLIC"
 GL-03 - CURTAINWALL GLAZING, CAPLESS, TO MATCH LIGHT GREY "PEX PEWTER METALLIC"
 GL-04 - WINDOW SPANDREL, TO MATCH LIGHT GREY "PEX PEWTER METALLIC"
 SP-02 - METAL PANEL, TO MATCH LIGHT GREY "PEX PEWTER METALLIC"

ALPOLIC "PEX PEWTER METALLIC" MATCH

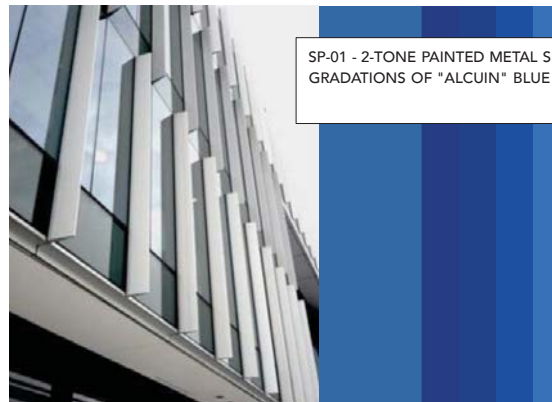

SP-01 - 2-TONE PAINTED METAL SHADING FINES
 GRADATIONS OF "ALCUIN" BLUE



WD-01 - WOOD SOFFIT, 5.5" WIDE PLANK

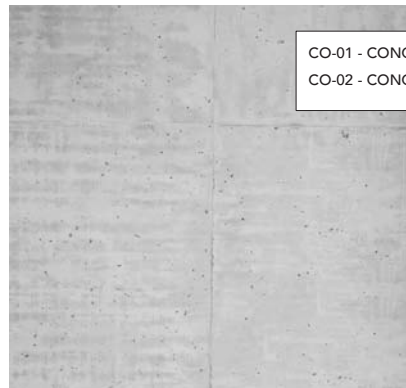

CO-01 - CONCRETE WALL, ARCHITECTURAL FINISH
 CO-02 - CONCRETE COLUMN, ARCHITECTURAL FINISH

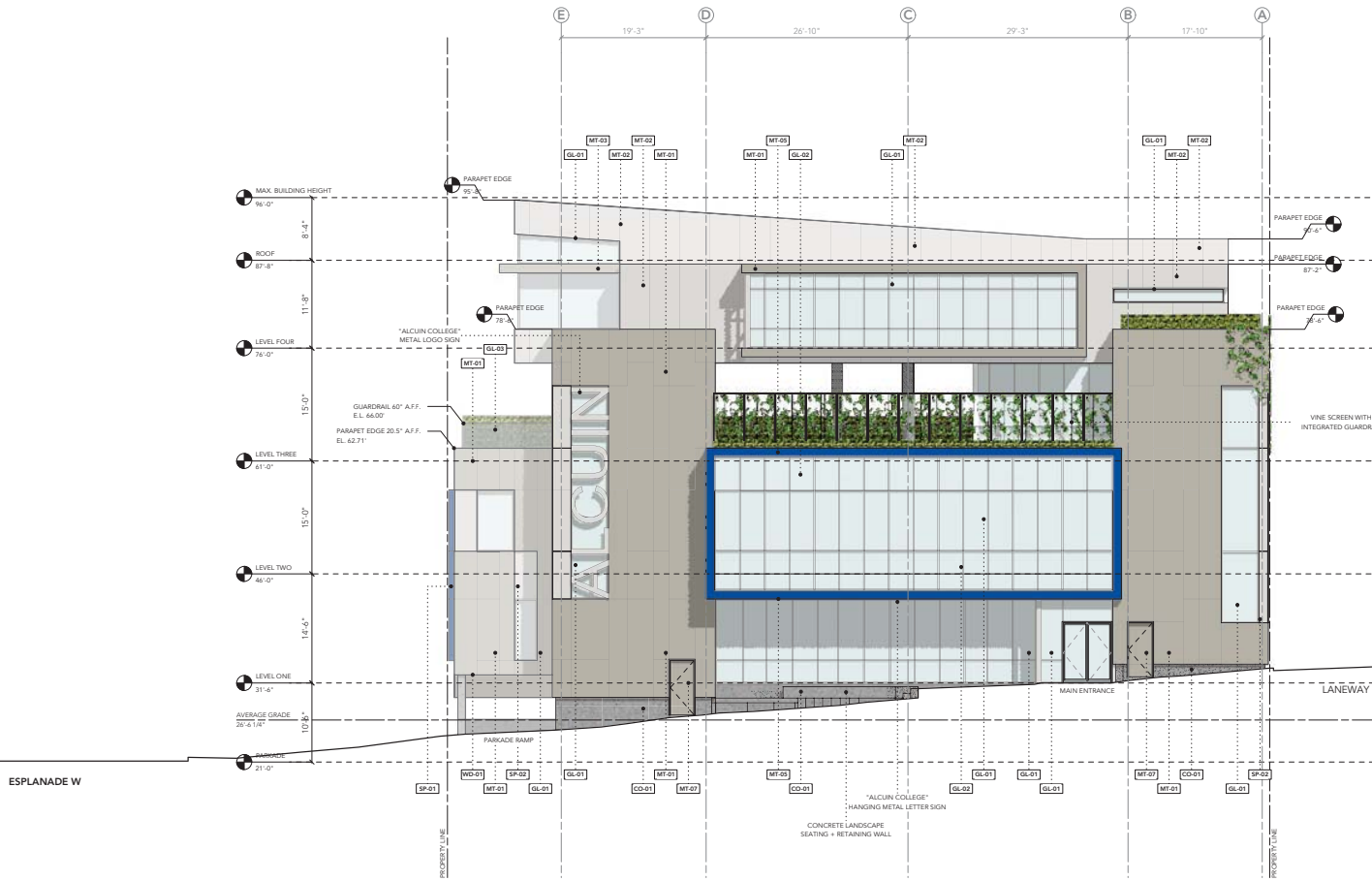

EXTERIOR MATERIALS

MT-01	METAL PANEL, VERTICAL	MEDIUM GREY (ALFREX "GREY SILVER")	WD-01	WOOD SOFFIT	TAUPE STAIN, 5.5" WIDE PLANKS, FINELINE JOINT
MT-02	METAL PANEL, VERTICAL	LIGHT GREY (ALPOLIC "PEX PEWTER METALLIC")			
MT-03	METAL PANEL, WALL PANEL	MEDIUM GREY (ALFREX "GREY SILVER")	GL-01	CURTAINWALL GLAZING	CLEAR ANODIZED FRAME TO MATCH LIGHT GREY
MT-04	METAL PANEL, WALL PANEL	LIGHT GREY (ALPOLIC "PEX PEWTER METALLIC")	GL-02	WINDOW SPANDREL	BACK PAINTED GLASS TO MATCH LIGHT GREY
MT-05	METAL PANEL, WALL PANEL	"ALCUIN" BLUE	GL-03	GLASS GUARDRAIL	FRAMELESS, ALUMINUM TOP CAP
MT-06	METAL PANEL, WALL PANEL	TO MATCH LIGHT GREY			
MT-07	METAL DOOR	MEDIUM GREY PAINTED METAL	SP-01	PAINTED METAL SHADING FINS	2-TONE "ALCUIN" BLUE + "APPLE FROTH GREEN"
			SP-02	METAL PANEL	TO MATCH LIGHT GREY
CO-01	CONCRETE	ARCHITECTURAL FINISH			

1 EAST ELEVATION
1/16" = 1'-0"



EXTERIOR MATERIALS

MT-01	METAL PANEL, VERTICAL	MEDIUM GREY (ALFREX "GREY SILVER")	WD-01	WOOD SOFFIT	TAUPE STAIN, 5.5" WIDE PLANKS, FINELINE JOINT
MT-02	METAL PANEL, VERTICAL	LIGHT GREY (ALPOLIC "PEX PEWTER METALLIC")			
MT-03	METAL PANEL, WALL PANEL	MEDIUM GREY (ALFREX "GREY SILVER")	GL-01	CURTAINWALL GLAZING	CLEAR ANODIZED FRAME TO MATCH LIGHT GREY
MT-04	METAL PANEL, WALL PANEL	LIGHT GREY (ALPOLIC "PEX PEWTER METALLIC")	GL-02	WINDOW SPANDREL	BACK PAINTED GLASS TO MATCH LIGHT GREY
MT-05	METAL PANEL, WALL PANEL	"ALCUIN" BLUE	GL-03	GLASS GUARDRAIL	FRAMELESS, ALUMINUM TOP CAP
MT-06	METAL PANEL, WALL PANEL	TO MATCH LIGHT GREY			
MT-07	METAL DOOR	MEDIUM GREY PAINTED METAL	SP-01	PAINTED METAL SHADING FINS	2-TONE "ALCUIN" BLUE + "APPLE FROTH GREEN"
			SP-02	METAL PANEL	TO MATCH LIGHT GREY
CO-01	CONCRETE	ARCHITECTURAL FINISH			

1 WEST ELEVATION
1/16" = 1'-0"

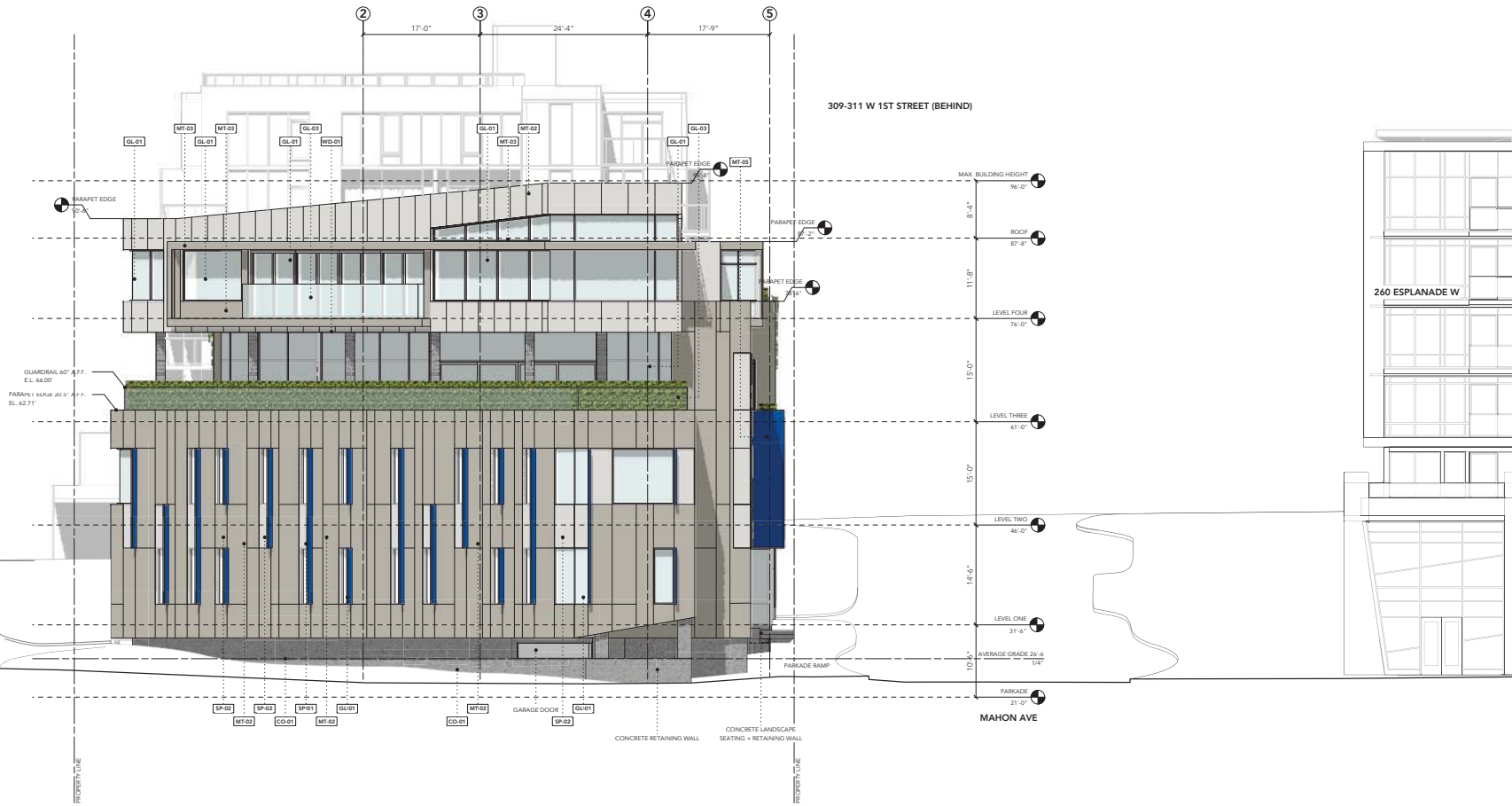

EXTERIOR MATERIALS

MT-01	METAL PANEL, VERTICAL	MEDIUM GREY (ALFREX "GREY SILVER")	WD-01	WOOD SOFFIT	TAUPE STAIN, 5.5" WIDE PLANKS, FINELINE JOINT
MT-02	METAL PANEL, VERTICAL	LIGHT GREY (ALPOLIC "PEX PEWTER METALLIC")			
MT-03	METAL PANEL, WALL PANEL	MEDIUM GREY (ALFREX "GREY SILVER")	GL-01	CURTAINWALL GLAZING	CLEAR ANODIZED FRAME TO MATCH LIGHT GREY
MT-04	METAL PANEL, WALL PANEL	LIGHT GREY (ALPOLIC "PEX PEWTER METALLIC")	GL-02	WINDOW SPANDREL	BACK PAINTED GLASS TO MATCH LIGHT GREY
MT-05	METAL PANEL, WALL PANEL	"ALCUIN" BLUE	GL-03	GLASS GUARDRAIL	FRAMELESS, ALUMINUM TOP CAP
MT-06	METAL PANEL, WALL PANEL	TO MATCH LIGHT GREY			
MT-07	METAL DOOR	MEDIUM GREY PAINTED METAL	SP-01	PAINTED METAL SHADING FINS	2-TONE "ALCUIN" BLUE + "APPLE FROTH GREEN"
			SP-02	METAL PANEL	TO MATCH LIGHT GREY
CO-01	CONCRETE	ARCHITECTURAL FINISH			

1 SOUTH ELEVATION
1/16" = 1'-0"

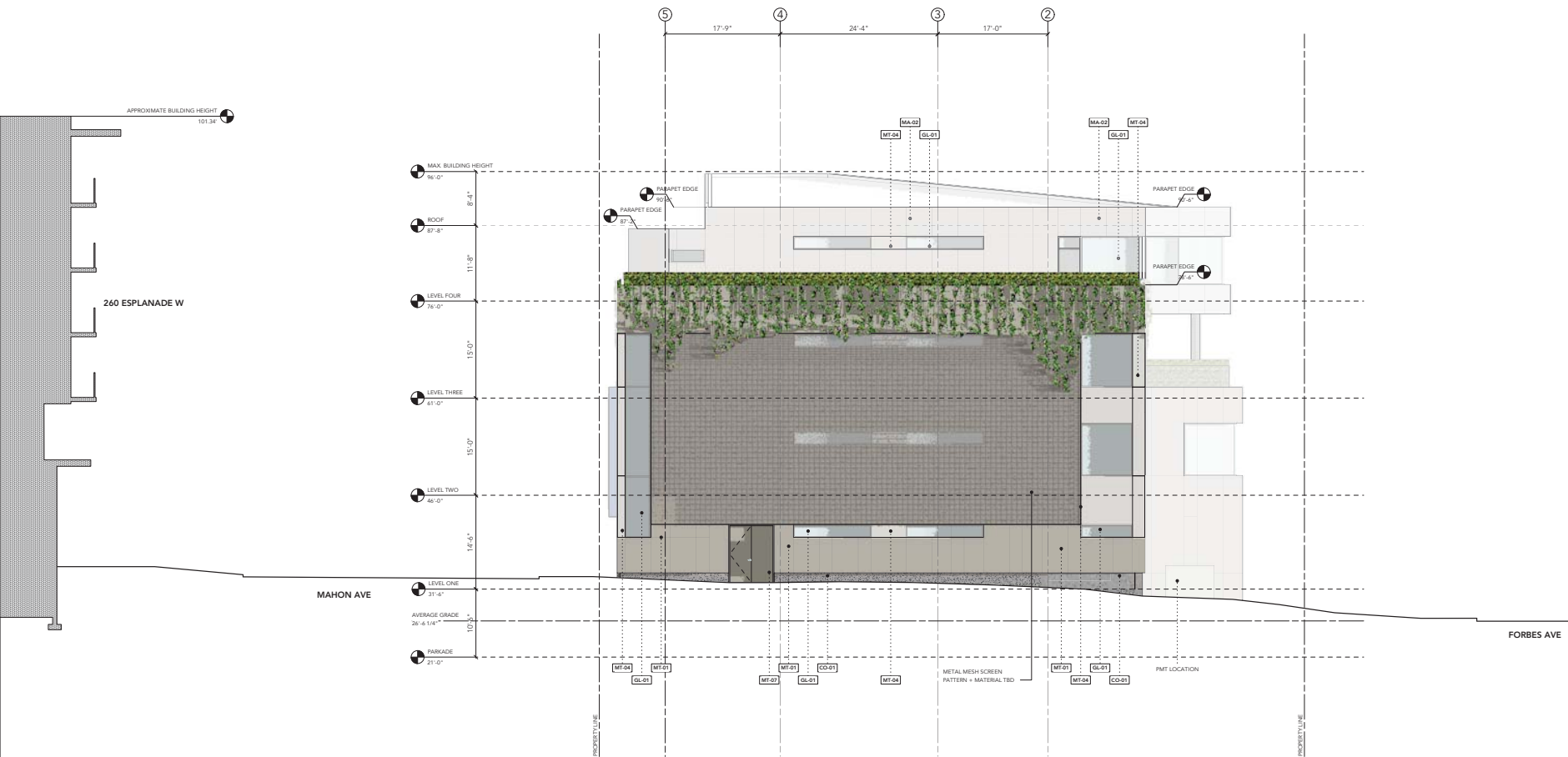

EXTERIOR MATERIALS

MT-01	METAL PANEL, VERTICAL	MEDIUM GREY (ALFREX "GREY SILVER")	WD-01	WOOD SOFFIT	TAUPE STAIN, 5.5" WIDE PLANKS, FINELINE JOINT
MT-02	METAL PANEL, VERTICAL	LIGHT GREY (ALPOLIC "PEX PEWTER METALLIC")			
MT-03	METAL PANEL, WALL PANEL	MEDIUM GREY (ALFREX "GREY SILVER")	GL-01	CURTAINWALL GLAZING	CLEAR ANODIZED FRAME TO MATCH LIGHT GREY
MT-04	METAL PANEL, WALL PANEL	LIGHT GREY (ALPOLIC "PEX PEWTER METALLIC")	GL-02	WINDOW SPANDREL	BACK PAINTED GLASS TO MATCH LIGHT GREY
MT-05	METAL PANEL, WALL PANEL	"ALCUIN" BLUE	GL-03	GLASS GUARDRAIL	FRAMELESS, ALUMINUM TOP CAP
MT-06	METAL PANEL, WALL PANEL	TO MATCH LIGHT GREY			
MT-07	METAL DOOR	MEDIUM GREY PAINTED METAL	SP-01	PAINTED METAL SHADING FINS	2-TONE "ALCUIN" BLUE + "APPLE FROTH GREEN"
			SP-02	METAL PANEL	TO MATCH LIGHT GREY
CO-01	CONCRETE	ARCHITECTURAL FINISH			

1 NORTH ELEVATION
1/16" = 1'-0"

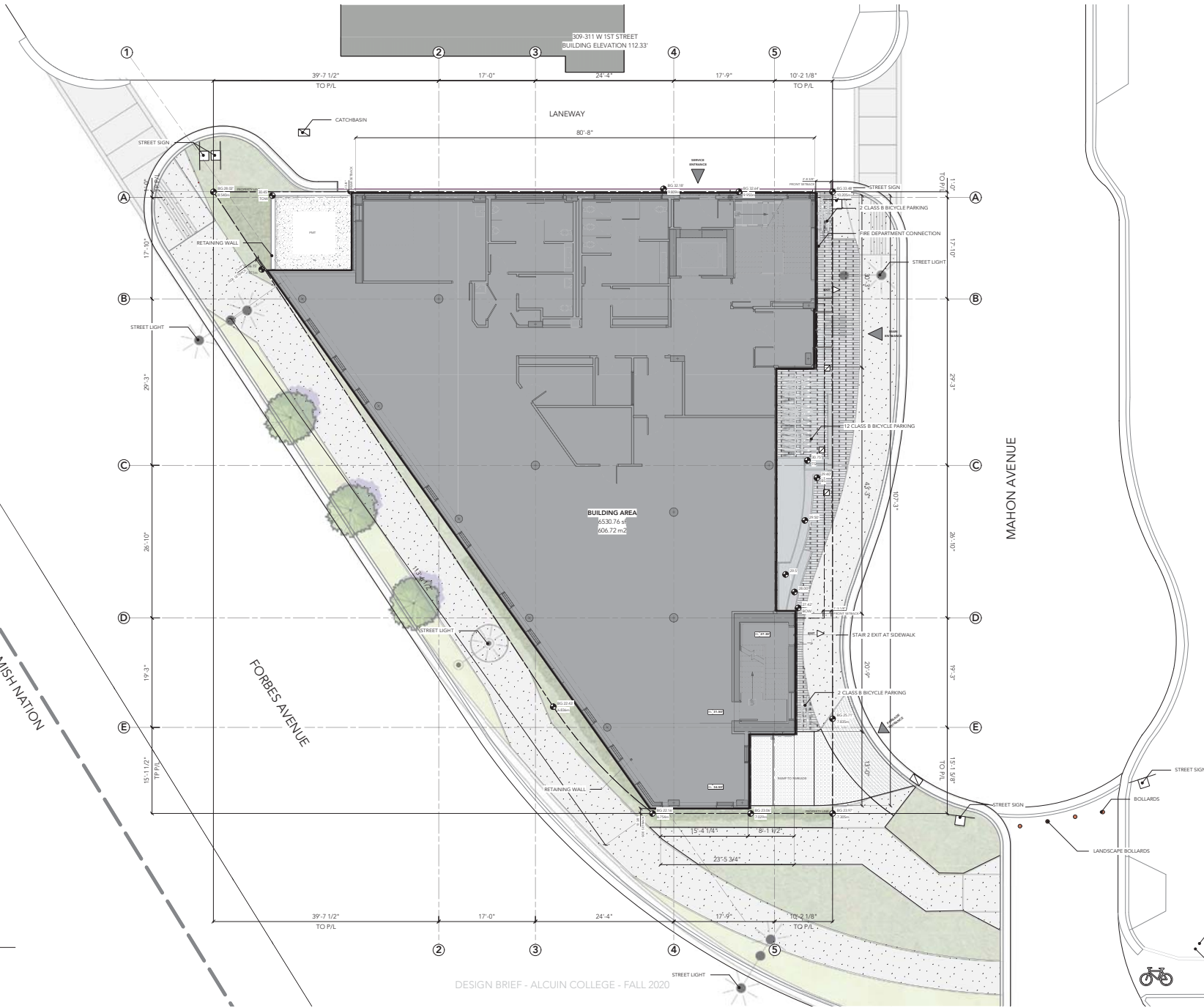

1 SITE PLAN
1/16" = 1'-0"

DESIGN BRIEF - ALQUIN COLLEGE - FALL 2020

4.3

DESIGN SITE PLAN

260 ESPLAN (E-W)
BUILDING ELEVATION 101.34'

EXISTING FIRE HYDRANT

EXISTING FIRE HYDRANT



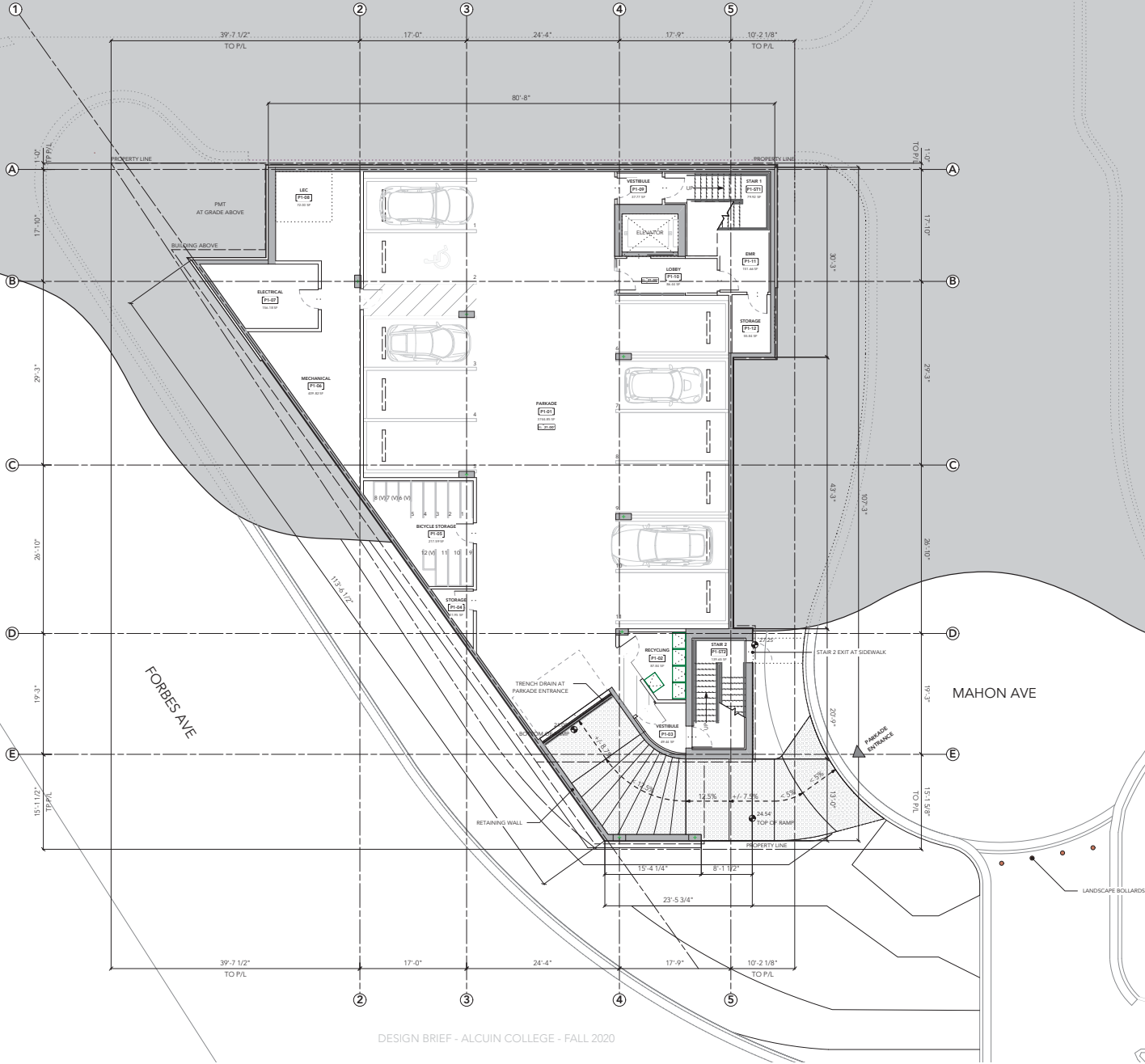

1 P1 PLAN
1/16" = 1'-0"



EXISTING FIRE HYDRANT

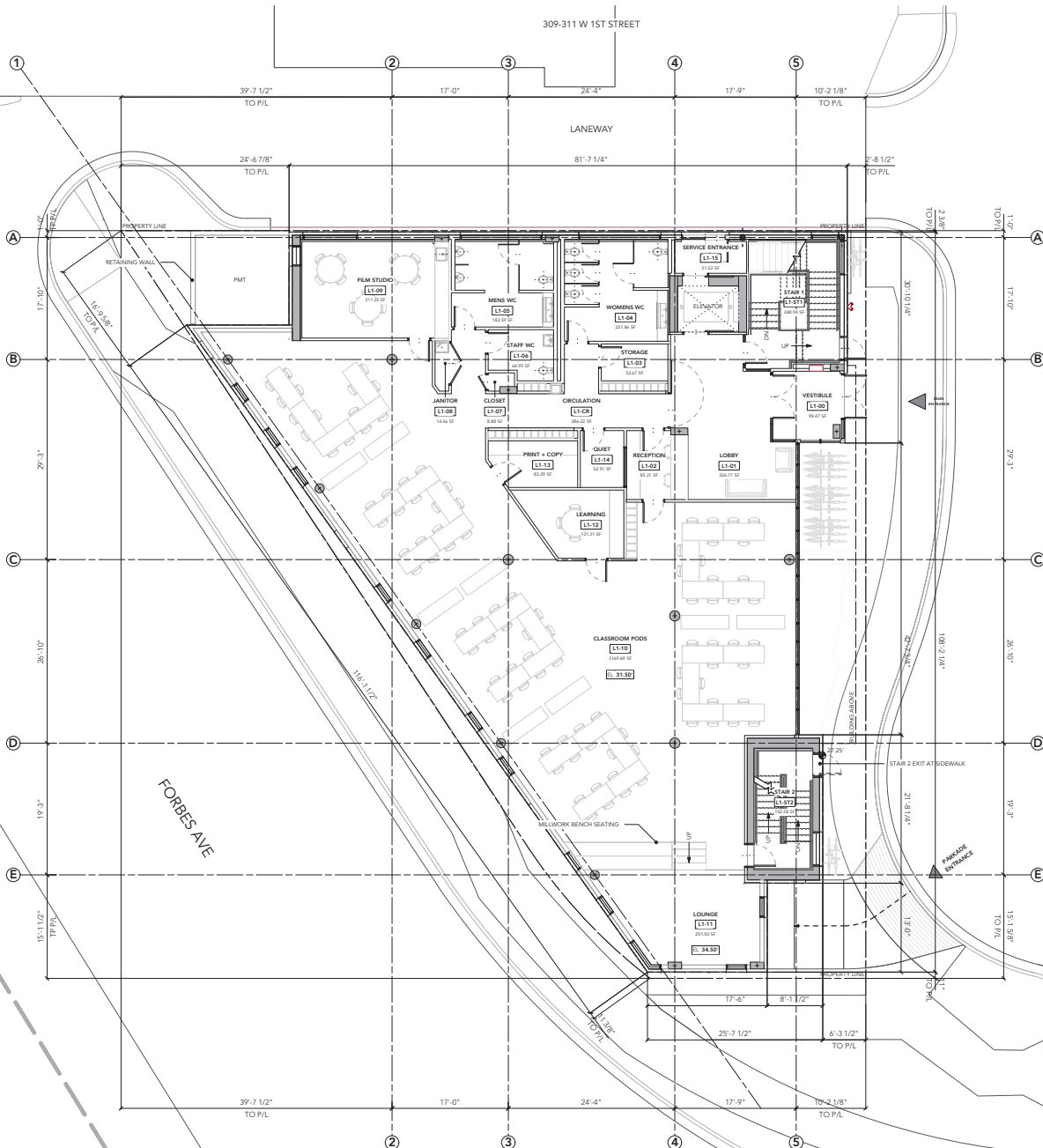

1 L1 PLAN
1/16" = 1'-0"



EXISTING
FIRE HYDRANT

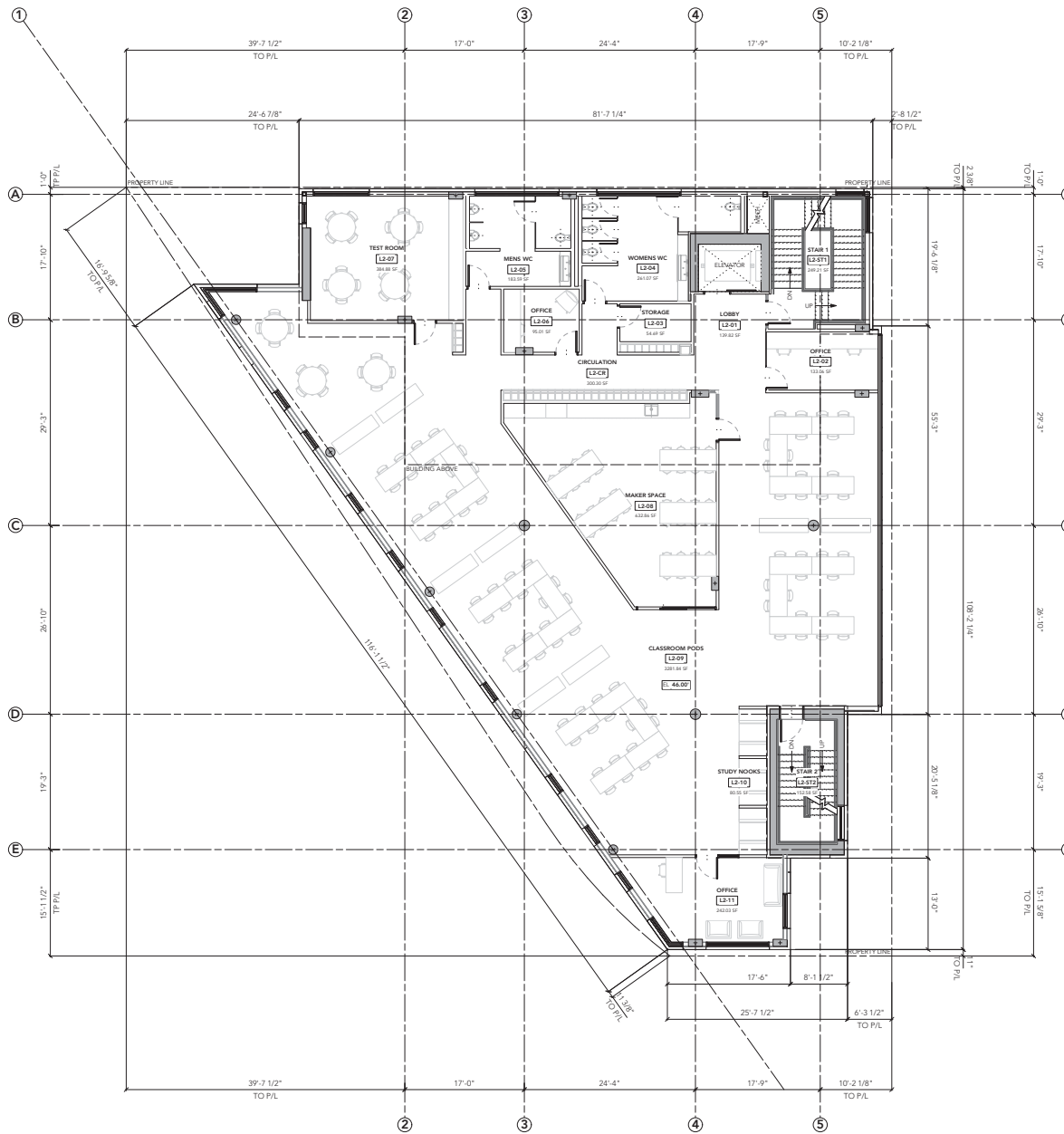

1 L2 PLAN
1/16" = 1'-0"

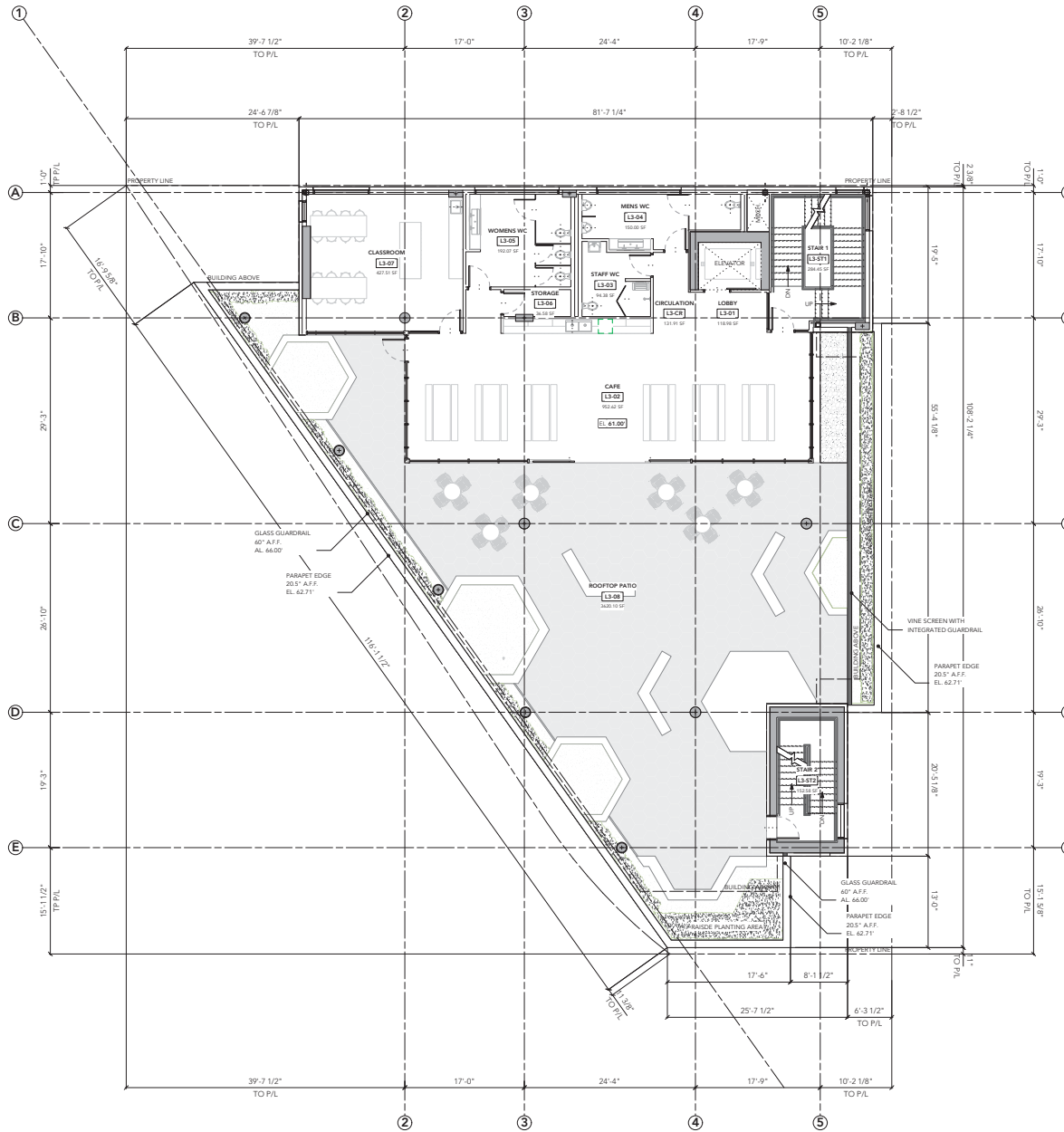

1 L3 PLAN
1/16" = 1'-0"

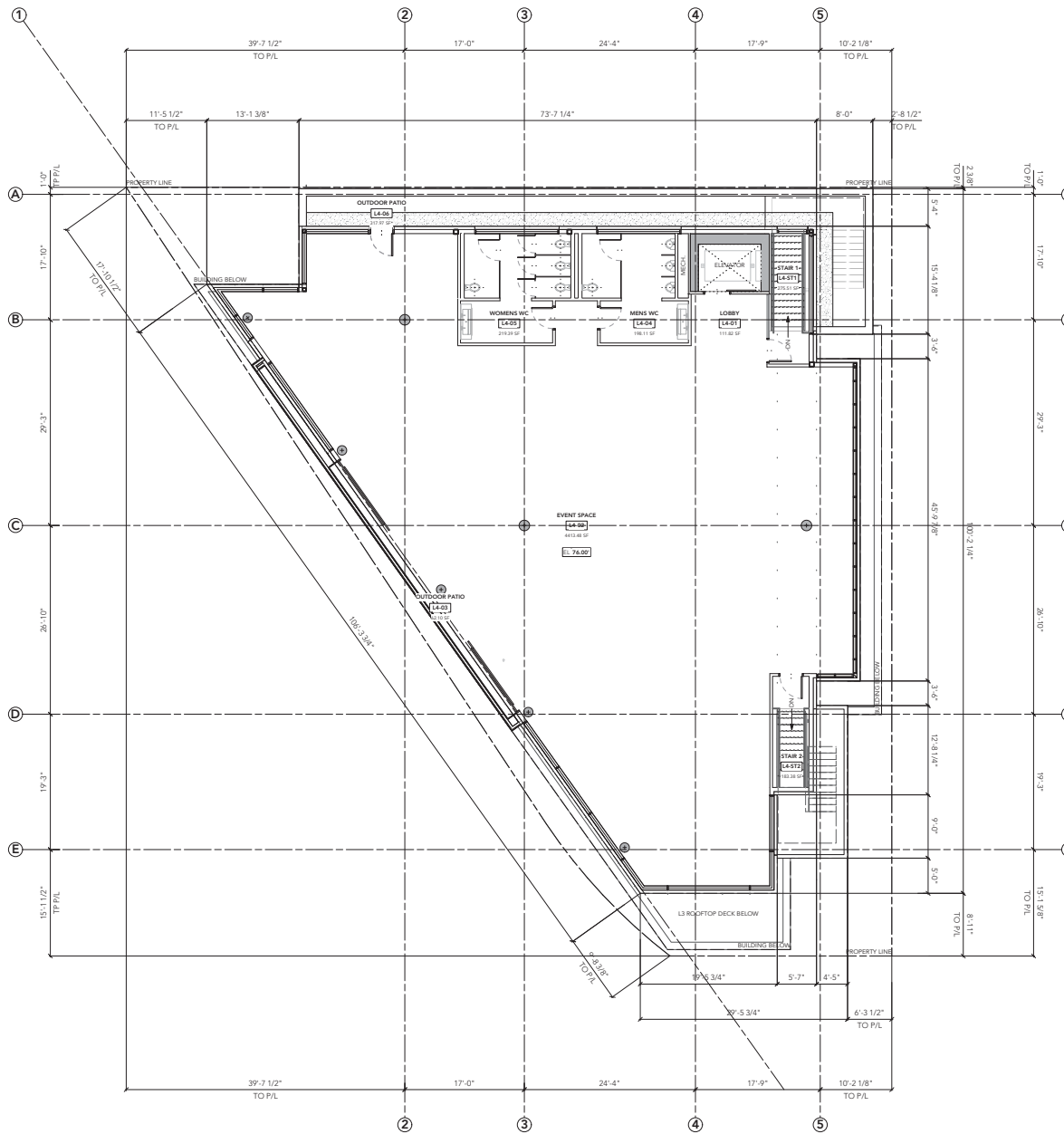

1 L4 PLAN
1/16" = 1'-0"

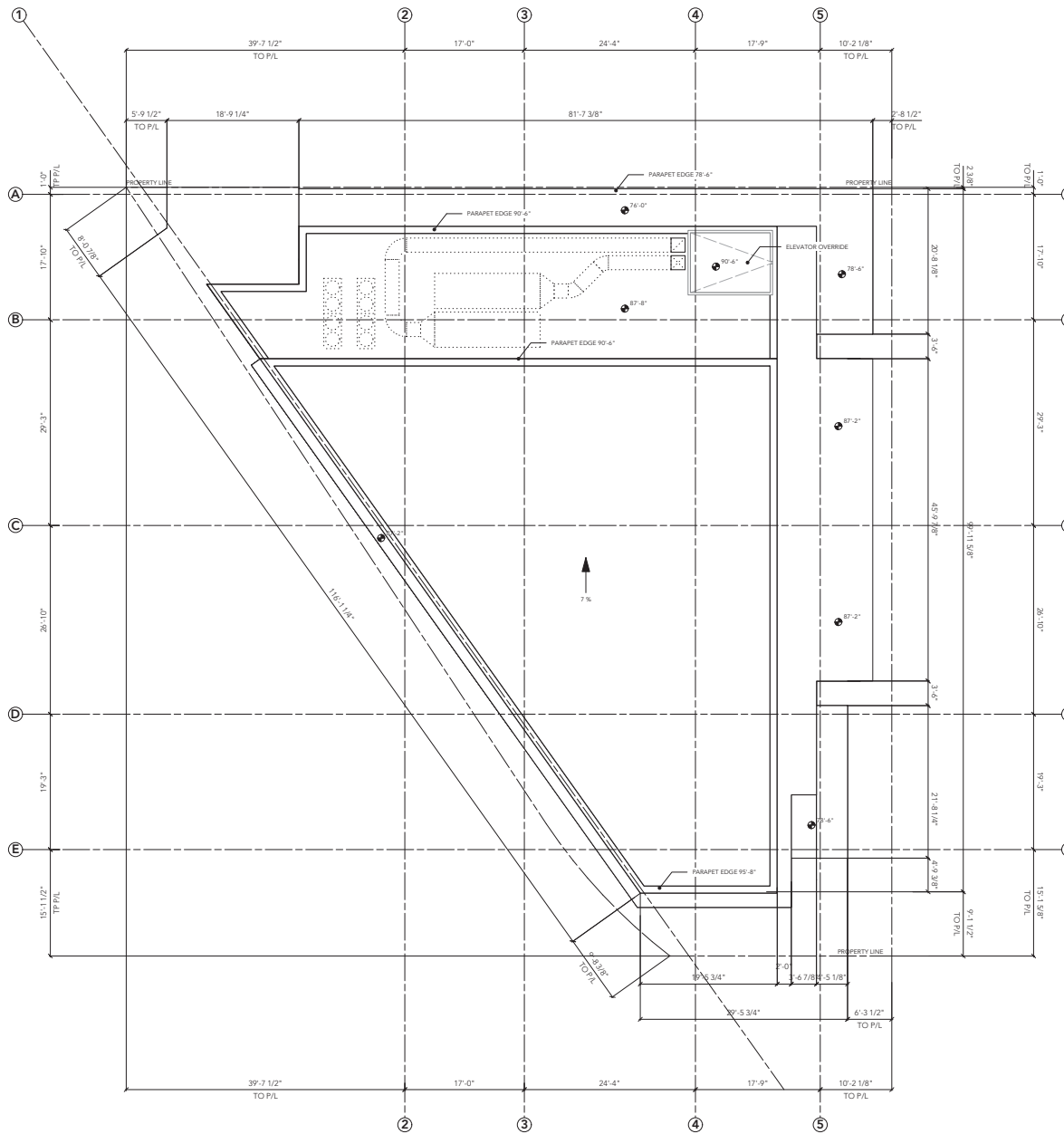

1 ROOF PLAN
1/16" = 1'-0"

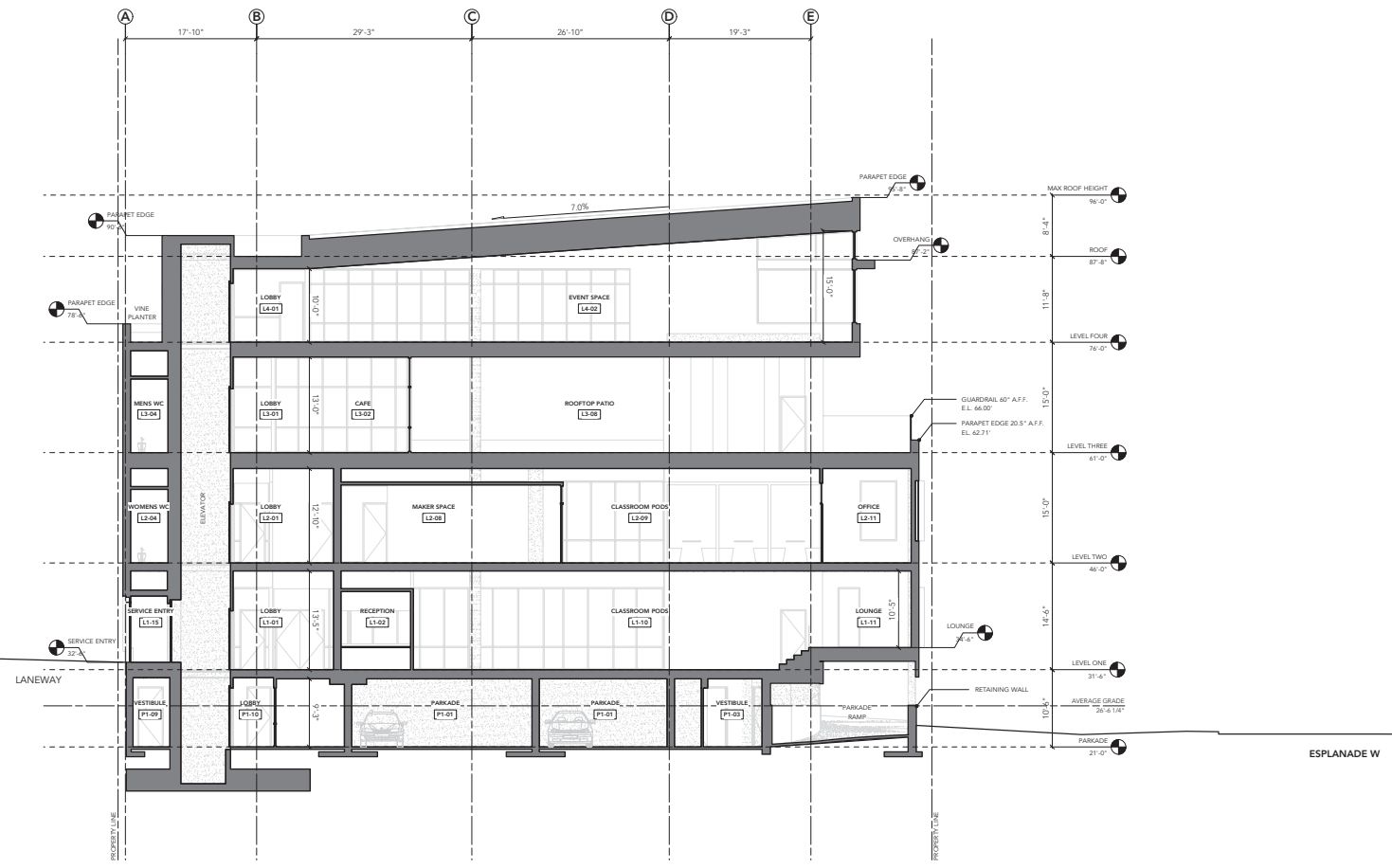
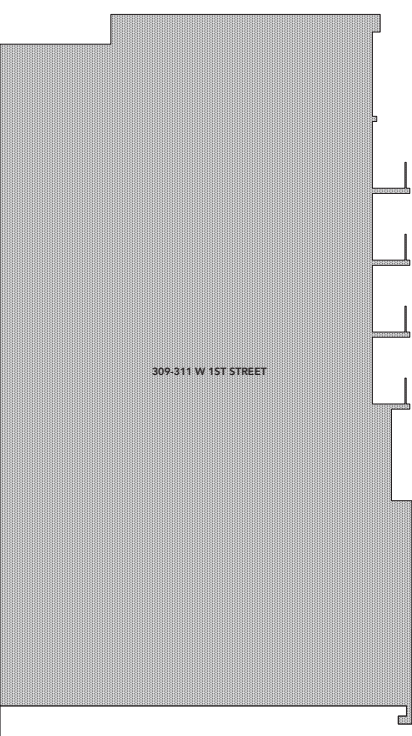

1 NORTH-SOUTH SECTION
1/16" = 1'-0"

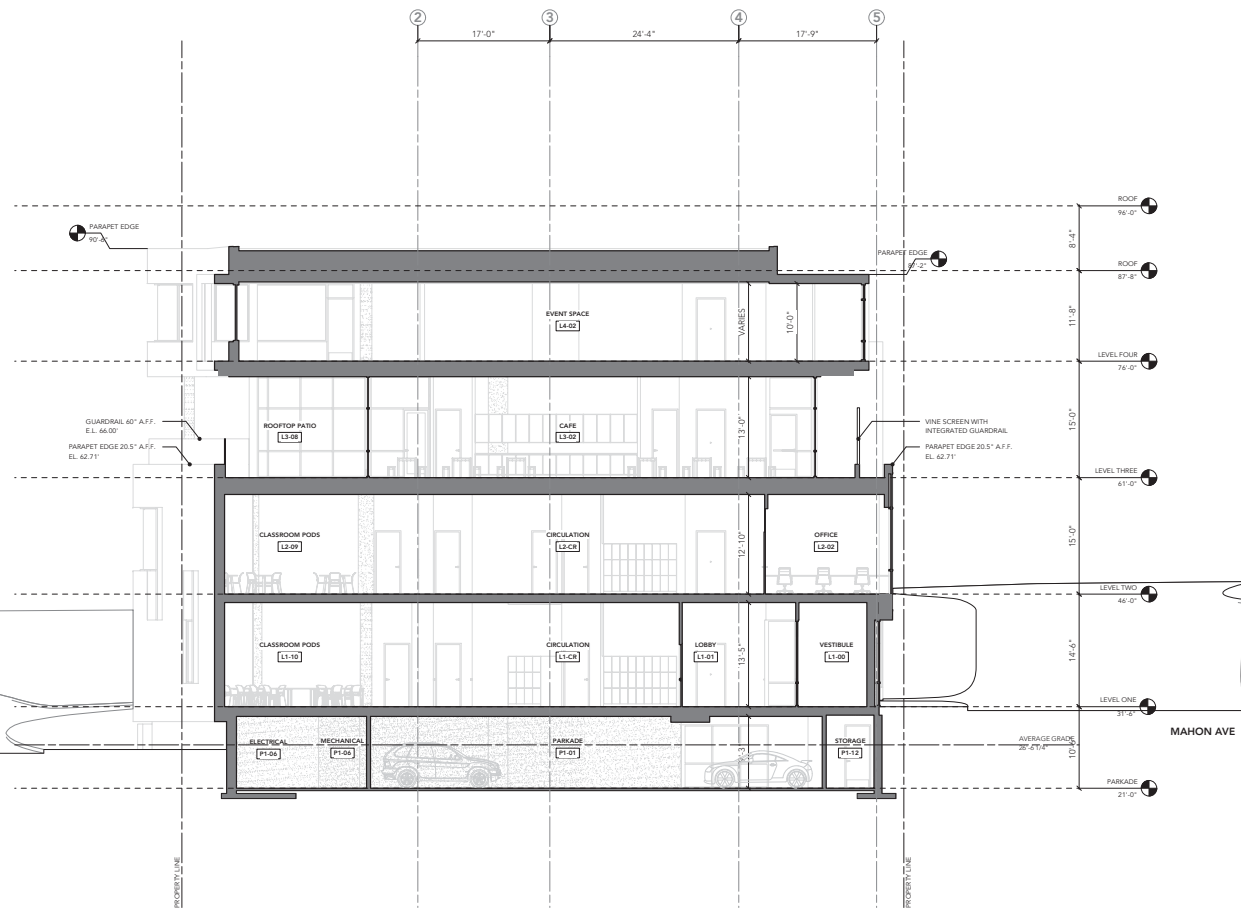

260 ESPLANADE W

1 WEST-EAST SECTION
1/16" = 1'-0"

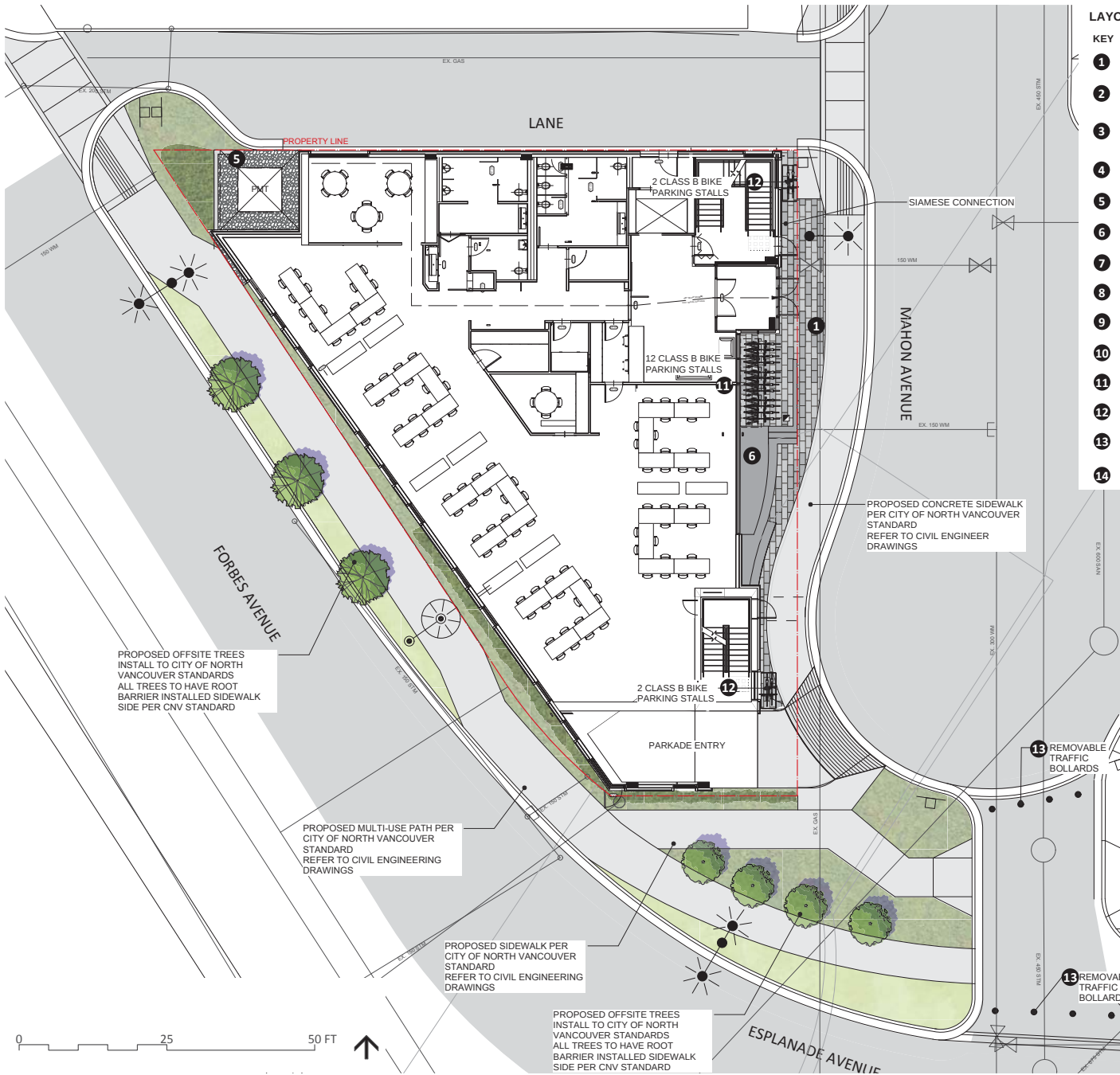

LAYOUT AND MATERIALS LEGEND

KEY	DESCRIPTION	SYMBOL	DETAIL
1	PEDESTRIAN UNIT PAVERS STANDARD 60mm DEPTH, CHARCOAL AND GREY		1 U.3
2	HYDRAPRESSED SLAB PAVERS 610mm x 305mm x 45mm, CHARCOAL AND GREY ON LEVEL 3 DECK		2A U.3
3	HYDRAPRESSED SLAB PAVERS 610mm x 305mm x 45mm, CHARCOAL AND GREY ON LEVEL 3 DECK		2B U.3
4	CIP CONCRETE WITH SAW CUT PATTERN, SANDBLAST FINISH		3 U.3
5	ROCK BUILDING SURROUND		5-6 U.3
6	ENTRY CIP CONCRETE SEAT WALL AND STAIR		1-2 U.3
7	STAGE/ DECK ON LEVEL 3 DECK		4 U.3
8	CUSTOM SEATING BENCH TYPES ON LEVEL 3 DECK		1 U.4
9	CIP CONCRETE PLANTER ON LEVEL 3 DECK		
10	METAL SCREEN WITH VINE PLANTING ON LEVEL 3 DECK		3 U.3
11	BIKE RACK DOBRA BOA B BIKE RACK STAINLESS STEEL		7 U.3
12	BIKE RACK MAGLIN (2 CLASS B BIKES PER RACK)		8 U.3
13	TRAFFIC BOLLARDS OFFSITE TO CNV DETAILS		
14	HOSE BIB REFER TO MECHANICAL		



INSPIRATION: HONEYCOMB



CONNECTION TO NATURE



HABITAT VALUE

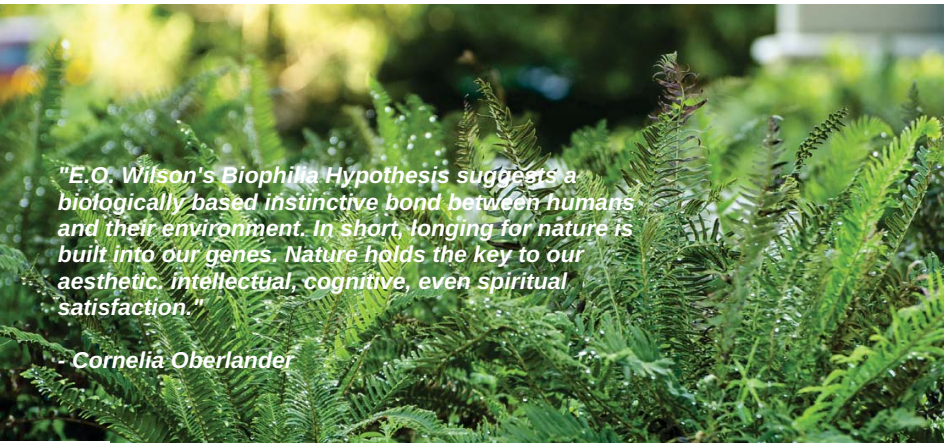

"E.O. Wilson's Biophilia Hypothesis suggests a biologically-based instinctive bond between humans and their environment. In short, longing for nature is built into our genes. Nature holds the key to our aesthetic, intellectual, cognitive, even spiritual satisfaction."

- Cornelia Oberlander



OUTDOOR LEARNING



INSPIRATION HONEY COMB

HONEYCOMB PAVERS

STAGE

DESIGN BY: FACULTY COLLEGE PARK

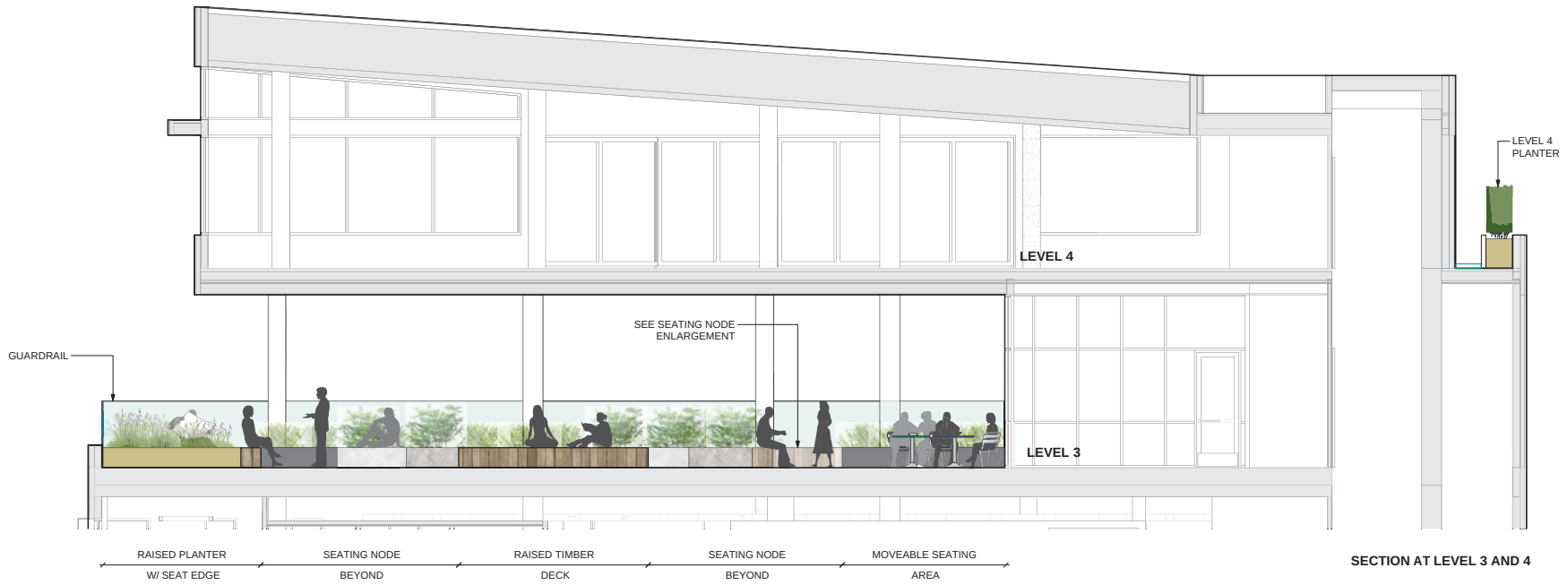
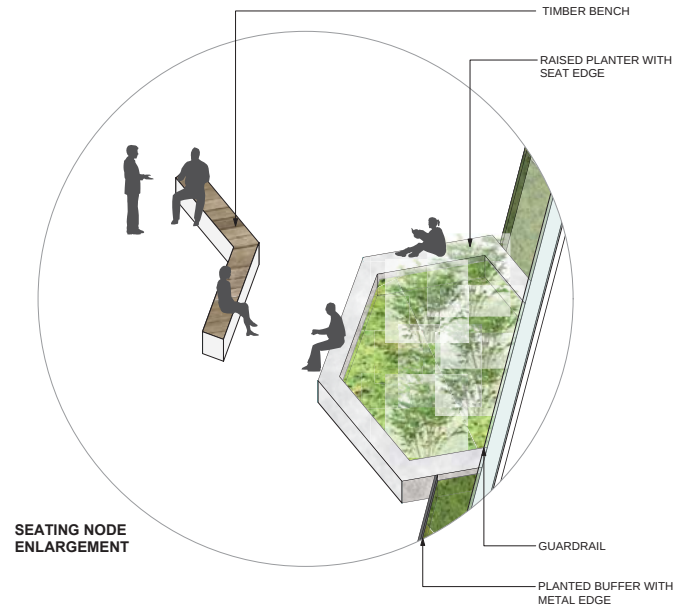
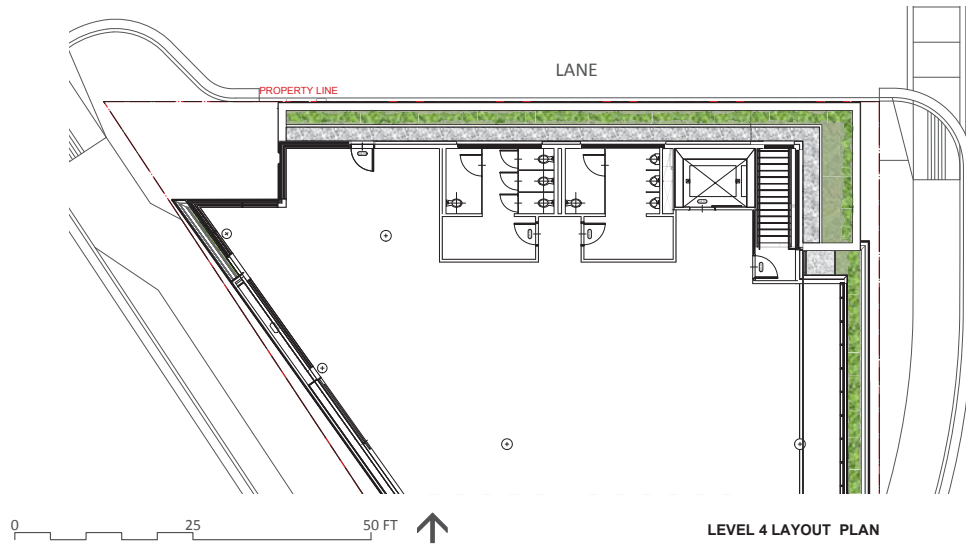

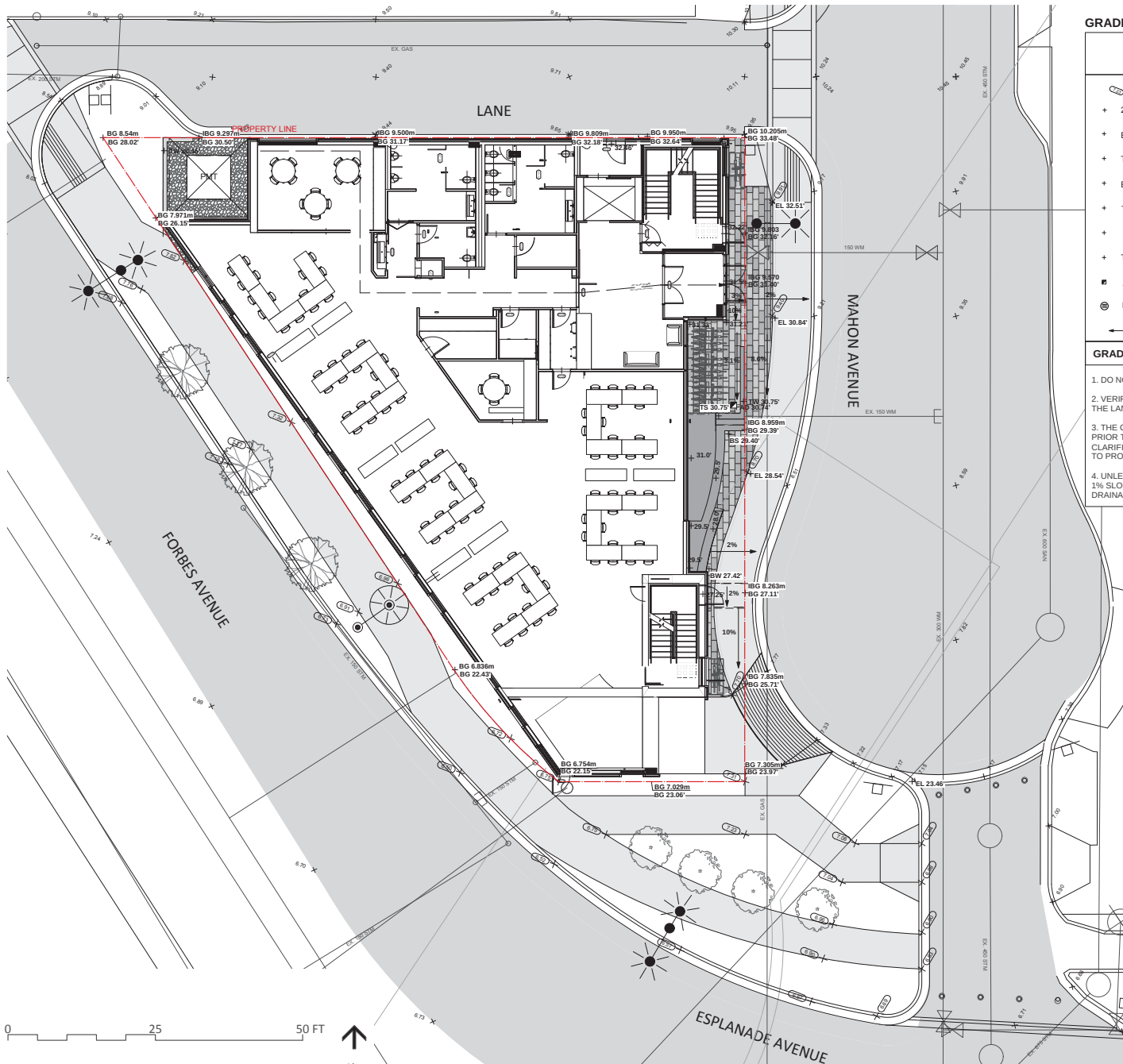

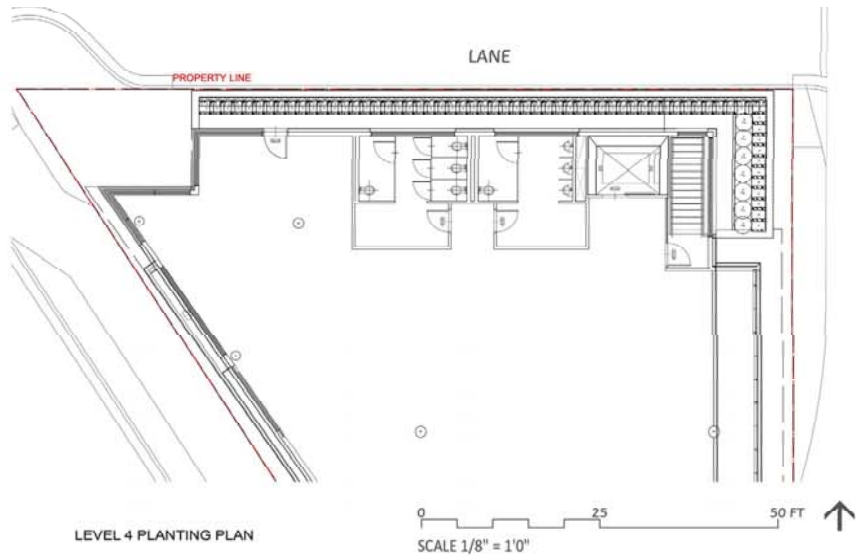
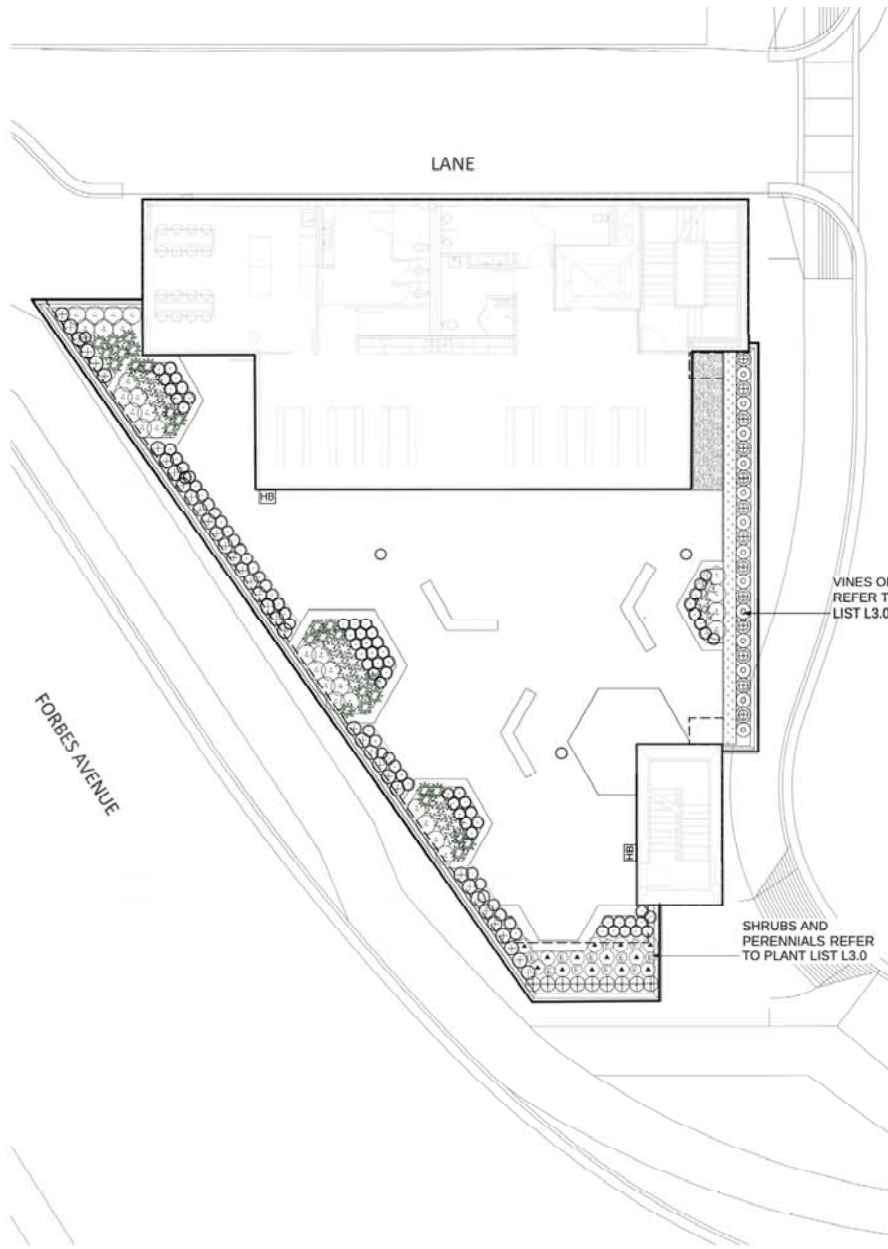

REFER TO L3.0 FOR PLANT LIST

PLANTING NOTES

1. ALL PLANTING SHALL BE IN ACCORDANCE WITH CANADIAN AND BC LANDSCAPE STANDARDS, LATEST EDITION.
2. ALL TREE AND SHRUB BEDS ARE TO BE MULCHED WITH 50mm OF 2" MEDIUM FINE MULCH, LESS THAN 50mm DIAMETER.
3. ALL LANDSCAPE AREAS TO BE IRRIGATED WITH HIGH EFFICIENCY IRRIGATION SYSTEM DESIGN BUILT SYSTEM.



IRRIGATION LEGEND

SYMBOL	DESCRIPTION
	MAIN CONNECTION (REFER TO MECHANICAL) 16.0 USGPM AT 50PSI, 1" DOUBLE CHECK VALVE & RAINBIRD #3 QUICK COUPLER
	TIME CLOCK RAINBIRD ESPSMTE-10 ZONES LOCATED IN MECHANICAL ROOM
	AUTO VALVE RAINBIRD 100 PGA
	AUTO VALVE RAINBIRD DV100F
	AUTO VALVE RAINBIRD XCZF-100-PRF
	WATER CONNECTION
	RAINBIRD 1806-PRS SPRINKLER c/w 12U' NOZZLE
	RAINBIRD 1806-PRS SPRINKLER c/w 10U' NOZZLE
	RAINBIRD 1806-PRS SPRINKLER c/w 8U' NOZZLE
	RAINBIRD 1806-PRS SPRINKLER c/w 5U' NOZZLE
	RAINBIRD 1806-PRS SPRINKLER c/w 15SST NOZZLE
	RAINBIRD 1806-PRS SPRINKLER c/w 15RCS OR LCS NOZZLE
	RAINBIRD 1806-PRS SPRINKLER c/w SQ-QTR NOZZLE
	RAINBIRD 1804-PRS SPRINKLER c/w 15SST NOZZLE PCS-060
	RAINBIRD XFS-09-12 DRIPLINE
	RAINBIRD SXB-180-SPYK XERI-BUBBLER (2 PER PLANTER)
	RAINBIRD SXB-180-SPYK XERI-BUBBLER (3 PER PLANTER)
	3/4" (2") LINE SIZE (SLEEVE SIZE)

IRRIGATION NOTES

1. FLOW THRU ALL PIPING NOT TO EXCEED 5FT. / SEC
2. ALL DRIPLINE TO BE LOOPED, INSTALL AIR / VACUUM RELIEF VALVE AT HIGH POINT OF EACH ZONE.
3. EXACT LOCATION OF PIPING RUNS TO BE DETERMINED ON SITE.
4. LOCATION OF WEATHER STATION AND WIRING RUN BETWEEN CONTROLLER & WEATHER STATION TO BE DETERMINED ON SITE.
5. ALL OFFSITE IRRIGATION TO MEET MUNICIPAL SPECIFICATIONS AND STANDARDS.
6. LEVEL 3 IRRIGATION TO BE HEAT TRACED SYSTEM TO OPERATE ALL YEAR.

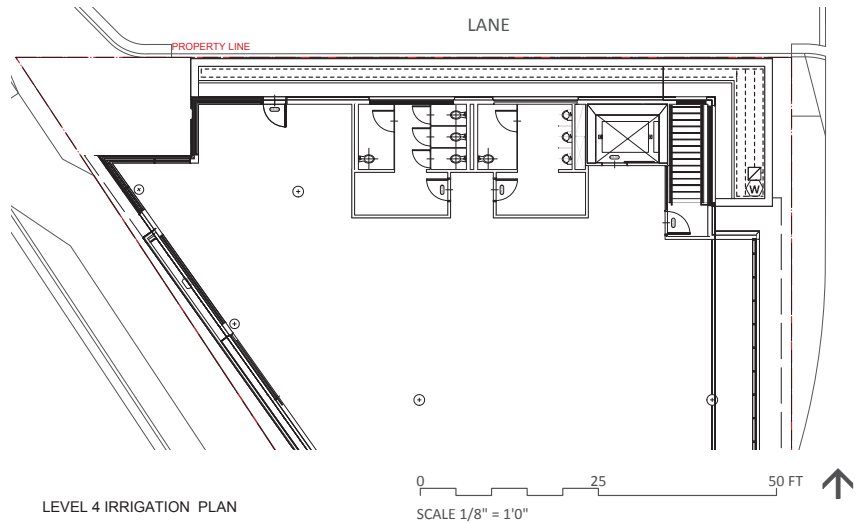
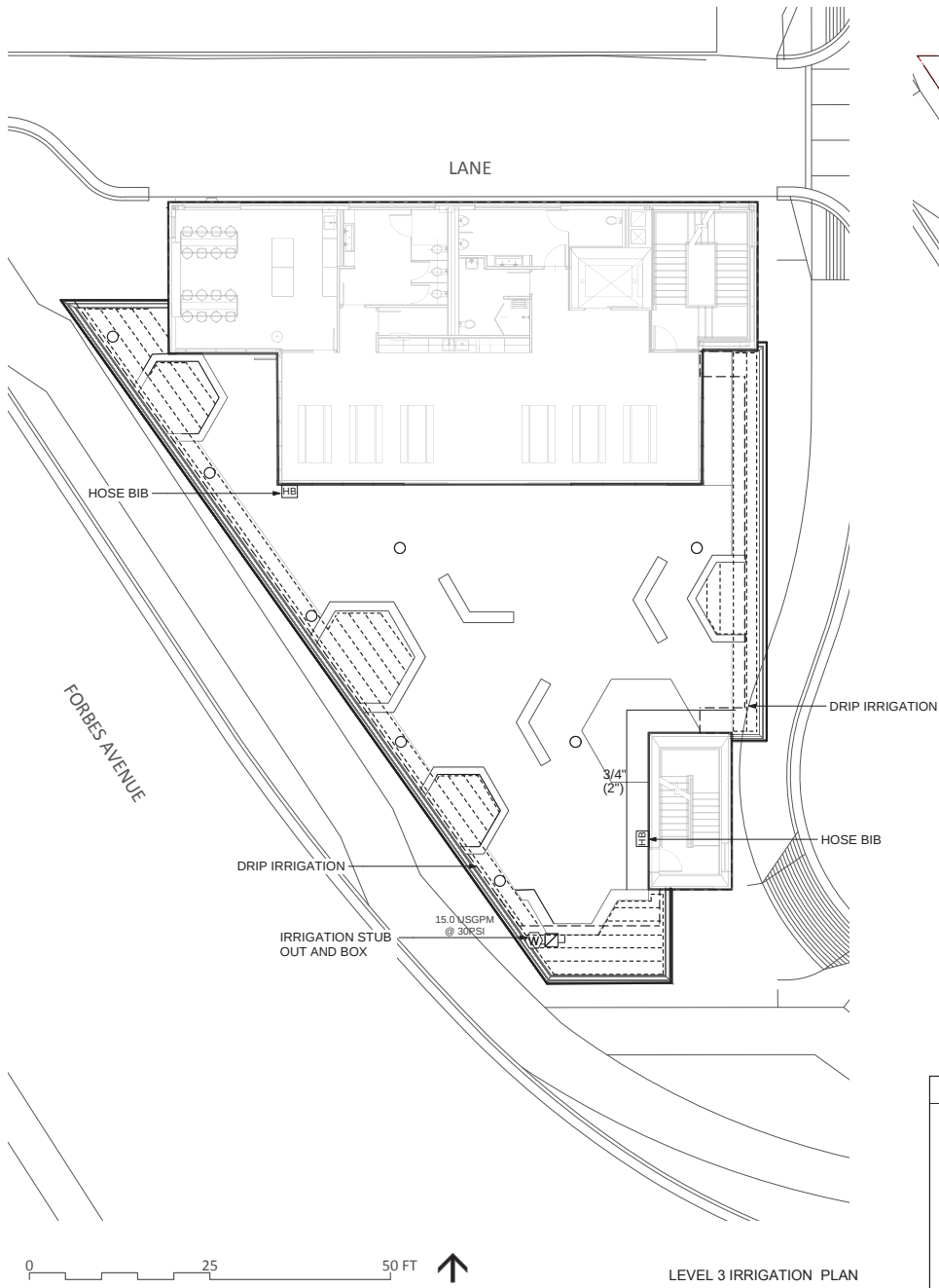

IRRIGATION LEGEND	
SYMBOL	DESCRIPTION
	MAIN CONNECTION (REFER TO MECHANICAL) 16.0 USGPM AT 50PSI, 1" DOUBLE CHECK VALVE & RAINBIRD #3 QUICK COUPLER
	TIME CLOCK RAINBIRD ESPSMTE-10 ZONES LOCATED IN MECHANICAL ROOM
	AUTO VALVE RAINBIRD 100 PGA
	AUTO VALVE RAINBIRD DV100F
	AUTO VALVE RAINBIRD XCZF-100-PRF
	WATER CONNECTION
	RAINBIRD 1806-PRS SPRINKLER c/w 12U' NOZZLE
	RAINBIRD 1806-PRS SPRINKLER c/w 10U' NOZZLE
	RAINBIRD 1806-PRS SPRINKLER c/w 8U' NOZZLE
	RAINBIRD 1806-PRS SPRINKLER c/w 5U' NOZZLE
	RAINBIRD 1806-PRS SPRINKLER c/w 15SST NOZZLE
	RAINBIRD 1806-PRS SPRINKLER c/w 15RCS OR LCS NOZZLE
	RAINBIRD 1806-PRS SPRINKLER c/w SQ-QTR NOZZLE
	RAINBIRD 1804-PRS SPRINKLER c/w 15SST NOZZLE PCS-060
	RAINBIRD XFS-09-12 DRIRLINE
	RAINBIRD SXB-180-SPYK XERI-BUBBLER (2 PER PLANTER)
	RAINBIRD SXB-180-SPYK XERI-BUBBLER (3 PER PLANTER)
	3/4" (2") LINE SIZE (SLEEVE SIZE)

- IRRIGATION NOTES**
1. FLOW THRU ALL PIPING NOT TO EXCEED 5FT. / SEC
 2. ALL DRIRLINE TO BE LOOPED, INSTALL AIR / VACUUM RELIEF VALVE AT HIGH POINT OF EACH ZONE.
 3. EXACT LOCATION OF PIPING RUNS TO BE DETERMINED ON SITE.
 4. LOCATION OF WEATHER STATION AND WIRING RUN BETWEEN CONTROLLER & WEATHER STATION TO BE DETERMINED ON SITE.
 5. ALL OFFSITE IRRIGATION TO MEET MUNICIPAL SPECIFICATIONS AND STANDARDS.
 6. LEVEL 3 IRRIGATION TO BE HEAT TRACED SYSTEM TO OPERATE ALL YEAR.

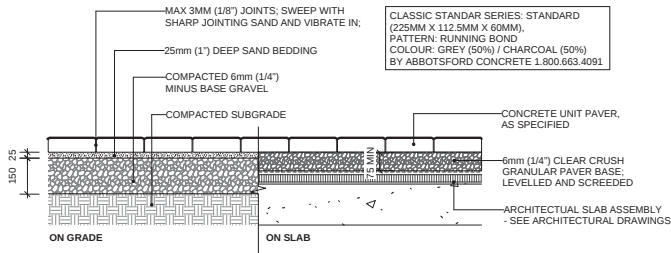

NOTES:
 1. USE CONCRETE HIDDEN EDGE RESTRAINT WHEN PAVERS ARE NOT ADJACENT TO A SOLID EDGE CONDITION.
 2. USE VOIDING IF REQUIRED; REFER TO ARCHITECTURAL DRAWINGS.

1 PEDESTRIAN PAVERS
 Scale: 1:10

TYPE A: HEXAGON PAVERS
 SIZE: 21.5"
 COLOURS: GREY (50%) / CHARCOAL (40%) RANDOM
 BY: STEPSTONE INC. PH 1-800-572-9029
 OR APPROVED ALTERNATE

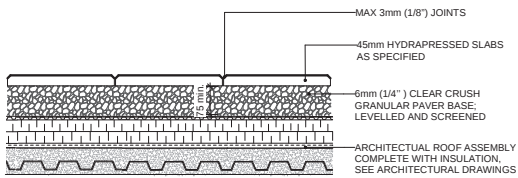

2 HYDRA-PRESSED PAVERS, ON SLAB
 Scale: 1:10

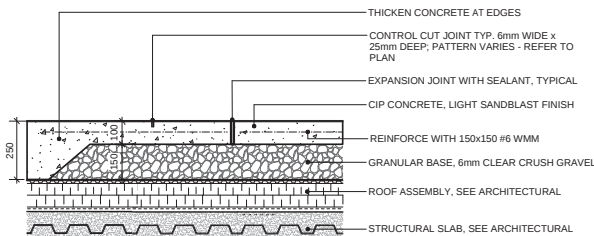

NOTES:
 1. EXPANSION JOINTS 6m O.C. MAX. CONTROL JOINTS @ 1.5m O.C. ADJUST TO SUIT SITE LAYOUT PLAN.
 2. ALL SCORELINES TO BE APPROVED BY LANDSCAPE ARCHITECT ON-SITE PRIOR TO INSTALLATION.

3 CIP CONCRETE ON SLAB (TYPICAL)
 Scale: 1:10

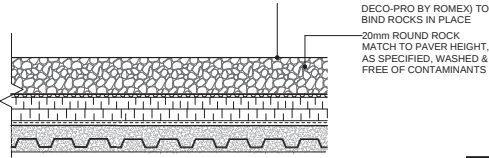

4 DECORATIVE ROCK SURFACE ON SLAB (TYPICAL)
 Scale: 1:10

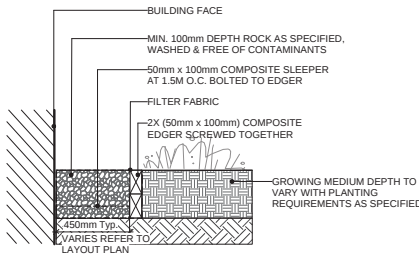

NOTE:
 1. COMPOSITE BOARDS TO BE BENDA BOARD LANDSCAPE EDGER BY WISHBONE SITE FURNISHINGS.

5 DRAINAGE STRIP ON GRADE
 Scale: 1:10

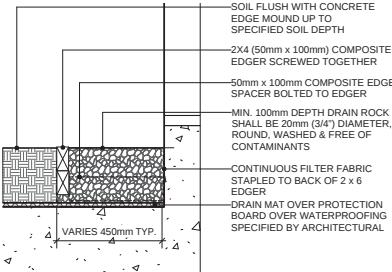

NOTE:
 1. COMPOSITE BOARDS TO BE BENDA BOARD LANDSCAPE EDGER BY WISHBONE SITE FURNISHINGS.

6 DRAINAGE STRIP ON SLAB
 Scale: 1:10 - SIGN BRIEF - ALQUIN COLLEGE - FALL 2020

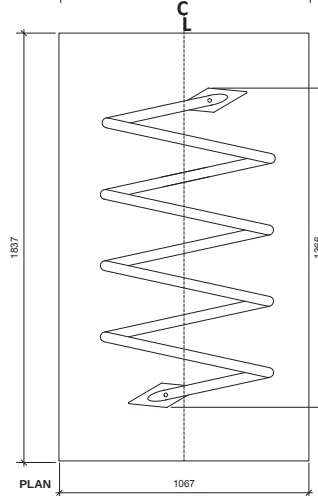
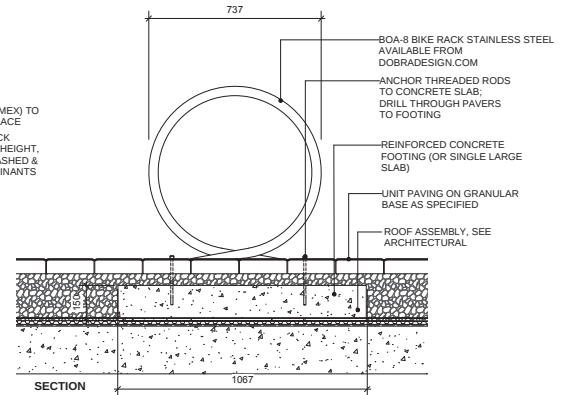

7 BIKE RACK TYPE 1
 Scale: 1:10

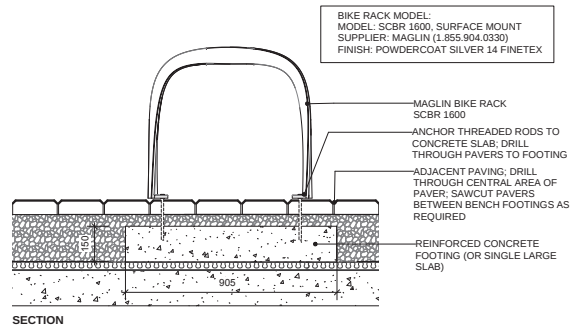

8 BIKE RACK TYPE 2
 Scale: 1:10

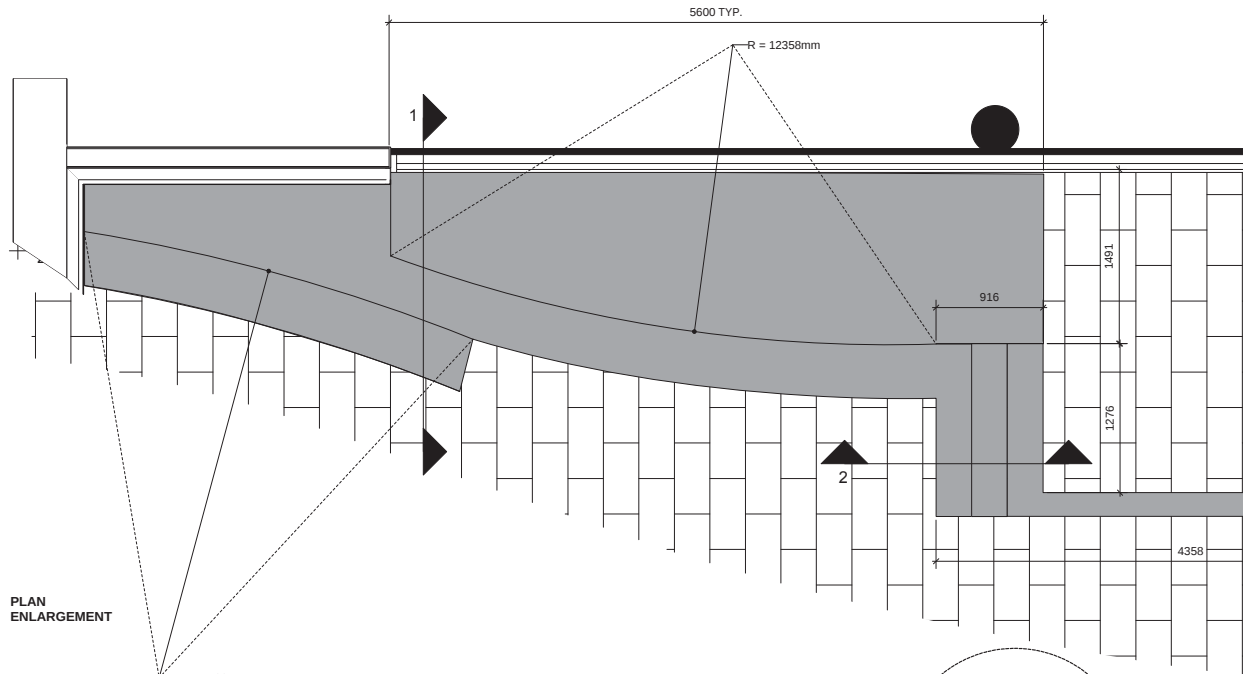

PLAN ENLARGEMENT

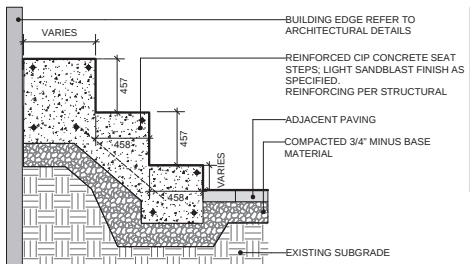

SECTION

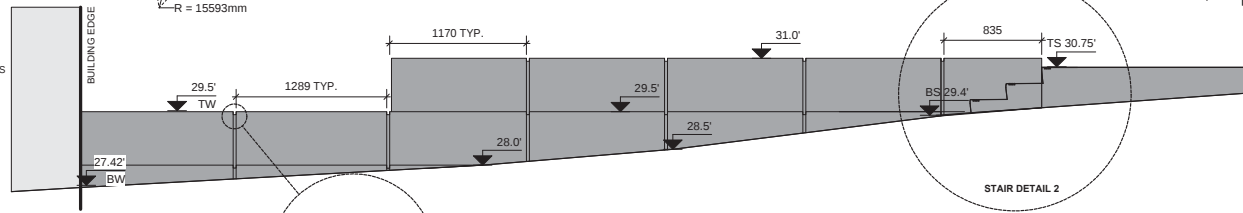

ELEVATION

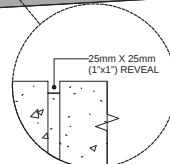

1 ENTRY CONCRETE SEAT WALL
Scale: 1:20

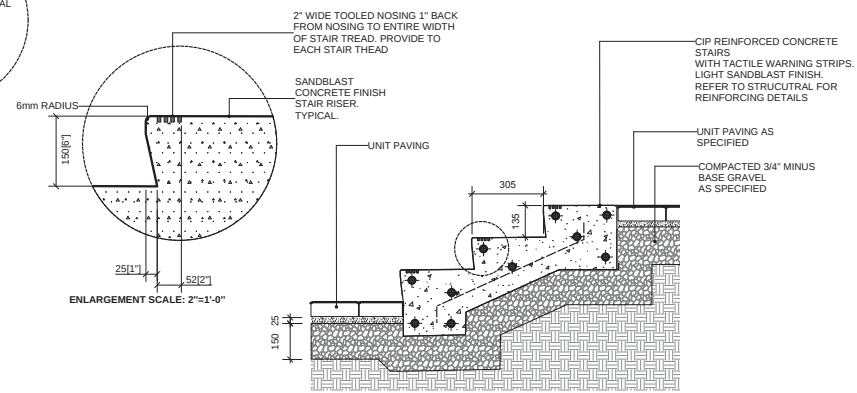

2 CIP CONCRETE STAIR
Scale: 1:10

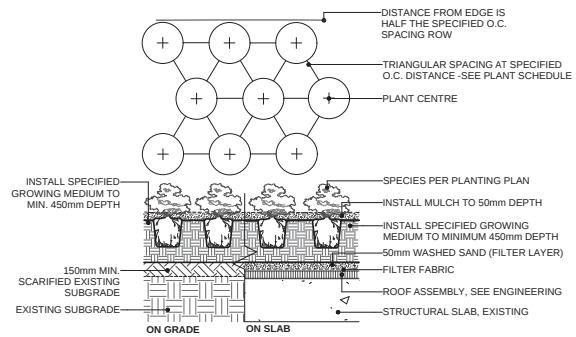

1 SHRUB AND GROUNDCOVER PLANTING (TYPICAL)
Scale: 1:25

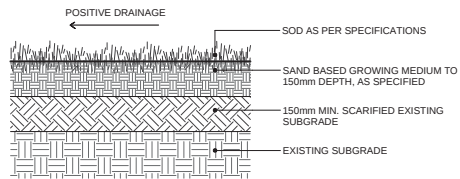

2 SOD LAWN ON GRADE (TYPICAL)
Scale: 1:10

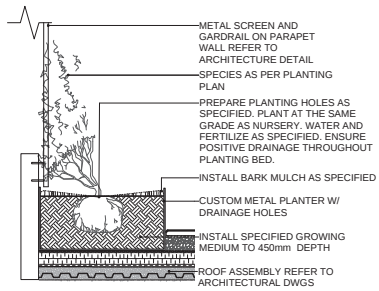

3 VINE PLANTING IN METAL PLANTER LEVEL 3 DECK
Scale: 1:20

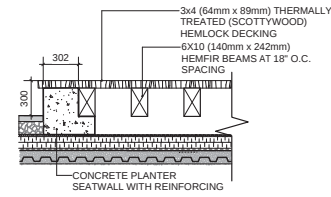

4A STAGE SECTION
Scale: 1:20

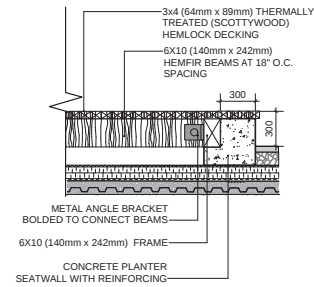

4B STAGE SECTION
Scale: 1:20

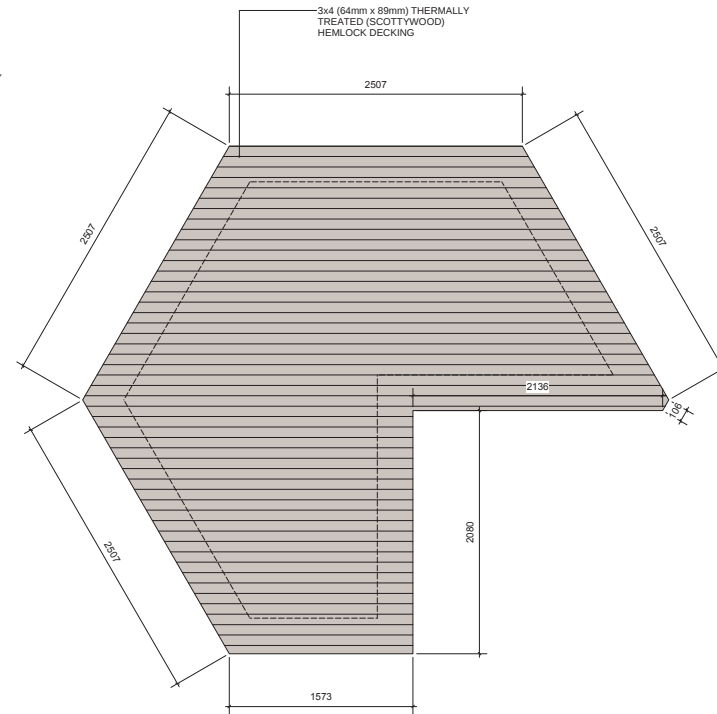

4C STAGE PLAN
Scale: 1:20

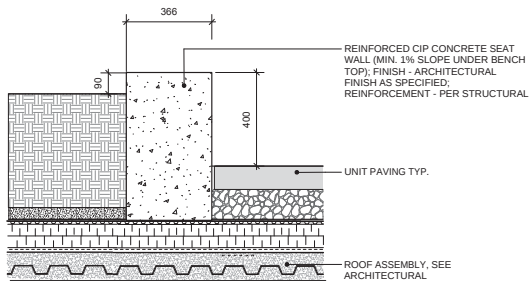

5 CONCRETE SEAT WALL LEVEL 3
Scale: 1:10

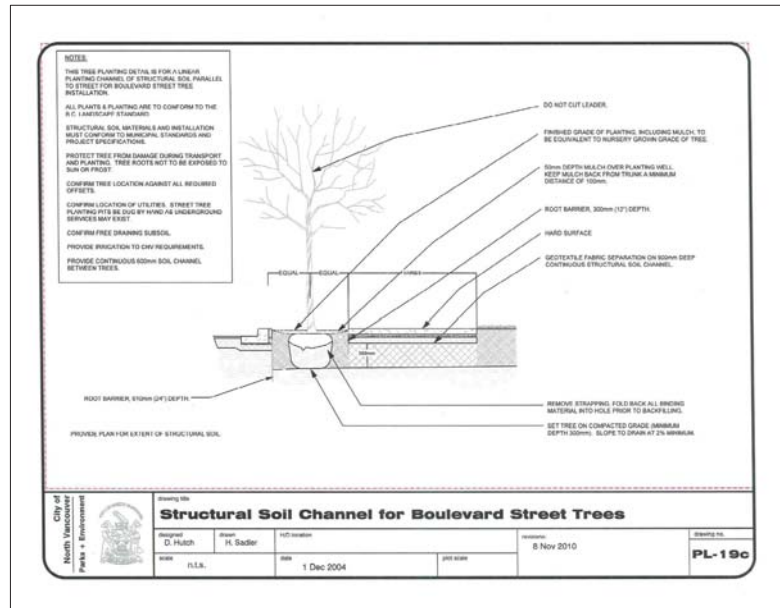
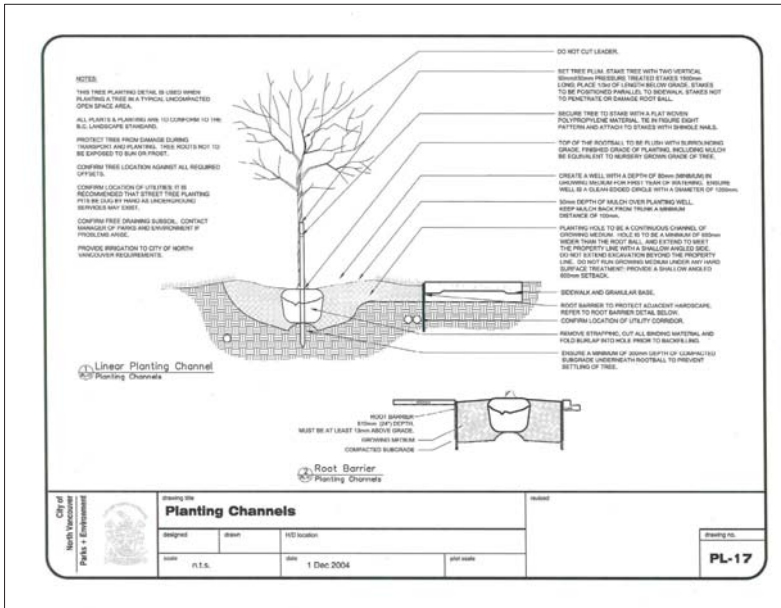

City of North Vancouver
Structural Soil Specification

1. Structural Soil Specification

1.1 General

Structural Soil is to be installed under hard surface paved areas where additional growing medium is required to provide adequate space for tree root development. Do not place Structural Soil in planting beds or planting pits.

1.2 Structural Soil Material Mix

1.2.1 Structural soil is a consistent even distribution of its components. The ratio of components may vary and require adjustment to ensure soil volume is adequate to fill all voids in the stone.

1.2.2 The following is a recommended base ratio of materials for structural soil:

- 4 cu metre of aggregate stone
- 1.5 cu metre of Growing Medium
- 2 kg Stabiliser
- Water is required – the amount of water will vary according to moisture present in Growing Medium

1.2.3 The stone, growing medium and stabilizer product are to be combined into a homogeneous mixture.

1.3 Growing Medium

1.3.1 Table One

The growing medium within the structural soil mix to meet the following requirements:

Table One – Properties of Growing Medium for Structural Soil	
Texture: particle size classes by the Canadian System of Soil Classification	
Gavel: greater than 2 mm – less than 75 mm	0
Sand: greater than 0.05 mm – less than 2 mm	maximum 60%
Silt: greater than 0.002 mm – less than 0.05 mm	maximum 35%
Clay less than 0.002 mm	maximum 15%
Clay & Silt Combined	maximum 40%
Acidity (pH)	6.0-7.0
Salinity: saturated extract conductivity shall not exceed	3.0 millimhos/cm at 25 degrees Celsius
Organic Content: percent of dry weight (%)	8-12%

City of North Vancouver
Structural Soil Specification

City of North Vancouver
Structural Soil Specification

1.4 Aggregate

1.4.1 Clean stone of high angularity is required.

1.4.2 Stone dimension aspect ratio should approach 1:1:1; with a maximum of 2:1:1 length:width:depth.

1.4.3 Single size stone, 60mm to 75mm clear sieve designation, blasted quarry rock.

1.4.4 Aggregate to be free of foreign elements or material.

1.4.5 Aggregate quality: material shall be sound hard, durable, free from soft, thin, elongated or laminated particles, organic material, clay lumps, or other substances that would act in a deleterious manner for use intended.

1.5 Soil Stabilizer

1.5.1 A non-toxic organic binder, for example *The Natural Solution* as available from Sport Turf Inc. Tel: (604) 850-7857.

1.6 Filter Fabric

1.6.1 After adequate compaction of the structural soil is confirmed, non-woven filter fabric is to be installed as a separation layer directly above the compacted structural soil mixture.

1.6.2 Filter fabric to conform to the following ASTM designations:

Grab Tensile Strength	ASTM-D-4632	400N
Tensile Elongation	ASTM-D-4632	50%
Mullen Burst	ASTM-D-3786	1270 kPa
Flow Rate	ASTM-D-4491	6300ml/min/sq.m

1.7 Sub Drains

1.7.1 Sub drains connected to the municipal drainage system are to be provided prior to installation of the structural soil mixture as indicated on servicing landscape plans.

1.8 Irrigation

1.8.1 Install an automatic irrigation system in co-ordination with installation of the structural soils as indicated on servicing or landscape plans.

1.9 Sub Grade

1.9.1 Structural soil areas to be excavated to Master Municipal Specifications Section 0223, Trenching, Excavation and Compaction, allowing for design depth and width of structural soil mix.

1.9.2 The sub grade is to be graded to provide for trench depths as required. Sub grade of areas designated as structural soil are to be prepared to ninety-five percent (95%) Modified Proctor Density and shall be free of stones, debris, root branches, toxic materials, building materials and other deleterious materials.

1.9.3 Sub grade is to slope to subsurface drain lines where provided.

City of North Vancouver
Structural Soil Specification

City of North Vancouver
Structural Soil Specification

1.10 Mixing

1.10.1 Mixing is to be performed on a clean, flat, hard, level surface using appropriate soil mixing equipment.

1.10.2 Over handling can result in separation of the growing medium from the stone.

1.10.3 Mix ingredients to the proportions indicated in the table, section 1.2.

1.11 Placement

1.11.1 Structural soil should be moist, but not saturated when placed.

1.11.2 Structural soil is to be compacted as required to achieve the equivalent of 95% Modified Proctor Density.

1.11.3 After approval of structural soil mixture compaction, install filter fabric. A 600mm overlap of all fabric seams and beyond edge of structural soil to be provided.

1.12 Finish Treatment

1.12.1 Granular base and paving surface to be placed on filter fabric (on structural soil). Compaction of the structural soil base is to be consistent with surrounding granular base materials.

1.12.2 Install finish treatment to the requirements of the contract. Refer to construction documents for relevant sections.

City of North Vancouver
Structural Soil Specification