



LOT A

652 EAST 4TH ST. NORTH VANCOVER

A100 - SITE PLAN

A101 - FOUNDATION PLAN

A102 - BASEMENT FLOOR PLAN

A103 - MAIN FLOOR PLAN

A104 - 2ND FLOOR PLAN

A105 - ROOF PLAN

A106 - ELEVATIONS - NORTH & SOUTH

A107 - ELEVATIONS - WEST

A108 - ELEVATIONS - EAST

A109 - SECTIONS

A110 - DETAILS

A111 - F.A.R

A112 - GARAGE

WWW.ROBERTBLANEYDESIGN.COM

604-626-6020

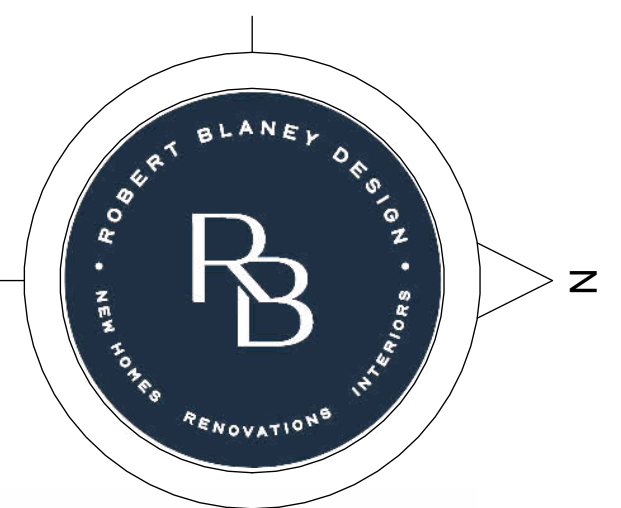

1 SITE
1/8" = 1'-0"

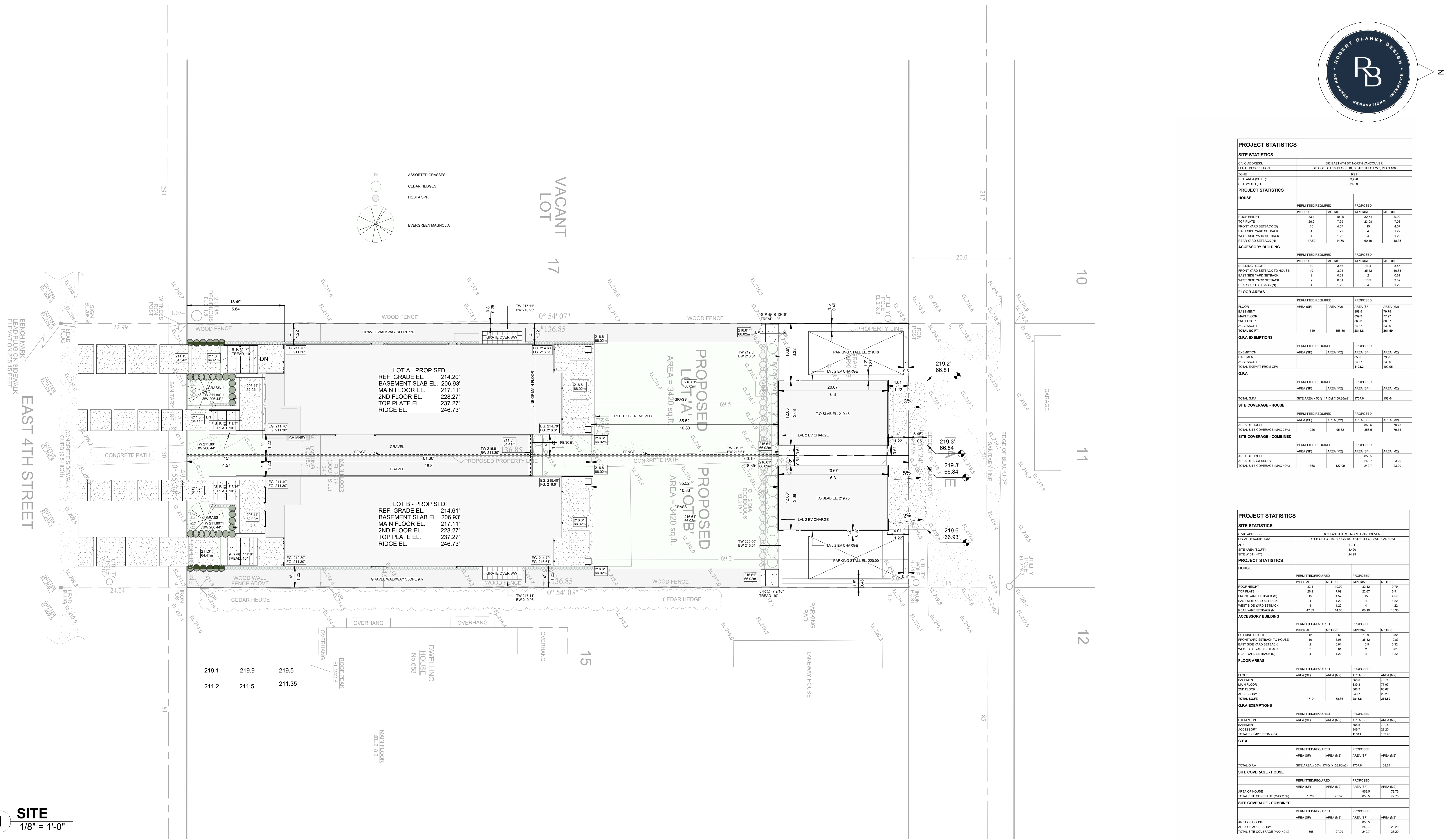

ROBERT BLANEY HOMES

5464 PATRICIA BAY HIGHWAY,
VICTORIA BC V8Y 2N9

(604) 626-6020
ROBERTBLANEYDESIGN@GMAIL.COM
WWW.ROBERTBLANEYDESIGN.COM

REVISIONS	
ISSUED FOR:	IFR
REVIEW SET:	01/23/07

PROJECT:
LOT A
652 EAST 4TH ST.
NORTH VANCOUVER

DRAWING TITLE:
SITE PLAN

SHEET:
A100

DRAWN BY:
JP

24X36 SCALE:
1/8" = 1'-0"

START DATE:
05.03.23

PROJECT NUMBER:
Project Number

COPYRIGHT RESERVED.

THIS DRAWING AND DESIGN ARE AND SHALL AT ALL TIMES REMAIN THE EXCLUSIVE PROPERTY OF ROBERT BLANEY DESIGN AND CANNOT BE USED OR REPRODUCED WITHOUT WRITTEN CONSENT. WRITTEN DIMENSIONS SHALL HAVE PRECEDENCE OVER SCALED DIMENSIONS. CONTRACTOR SHALL VERIFY AND SHALL BE RESPONSIBLE FOR ALL DIMENSIONS AND CONDITIONS ON THE JOB AND THIS OFFICE SHALL BE INFORMED OF ANY VARIATIONS FROM THE DIMENSIONS AND CONDITIONS AS SHOWN ON THIS DRAWING. CONTRACTORS SHALL ENSURE THAT ALL CONSTRUCTION WILL COMPLY TO ALL APPLICABLE BUILDING CODES. ROBERT BLANEY DESIGN WILL NOT ACCEPT RESPONSIBILITY FOR VARIATIONS OR MODIFICATION OF THESE PLANS.

PROJECT STATISTICS			
SITE STATISTICS			
CIVIC ADDRESS:		652 EAST 4TH ST NORTH VANCOUVER	
LEGAL DESCRIPTION:		LOT A OF LOT 16, BLOCK 18, DISTRICT LOT 273, PLAN 1083	
ZONE:		RS1	
SITE AREA (SQ FT):		3420	
SITE WIDTH (FT):		24.99	
PROJECT STATISTICS			
HOUSE		PERMITTED/REQUIRED	PROPOSED
		IMPERIAL	METRIC
ROOF HEIGHT	33.1	10.09	32.54
TOP PLATE	26.2	7.99	23.08
FRONT YARD SETBACK (S)	15	4.57	15
EAST SIDE YARD SETBACK	4	1.22	4
WEST SIDE YARD SETBACK	4	1.22	4
REAR YARD SETBACK (N)	47.89	14.60	60.19
ACCESSORY BUILDING		PERMITTED/REQUIRED	PROPOSED
		IMPERIAL	METRIC
BUILDING HEIGHT	10	3.05	11.4
FRONT YARD SETBACK TO HOUSE	2	0.61	2
EAST SIDE YARD SETBACK	2	0.61	2
WEST SIDE YARD SETBACK	4	1.22	4
REAR YARD SETBACK (N)	4	1.22	4

FLOOR AREAS			
FLOOR	PERMITTED/REQUIRED	PROPOSED	
	AREA (SF)	AREA (M2)	AREA (SF)
BASEMENT	86.5	79.75	
MAIN FLOOR	838.3	77.97	
2ND FLOOR	866.3	80.07	
ACCESSORY	249.7	23.20	
TOTAL SQ FT	1710	158.86	2815.8
G.F.A. EXEMPTIONS			
EXEMPTION	AREA (SF)	AREA (M2)	AREA (SF)
BASEMENT			86.5
ACCESSORY			249.7
TOTAL EXEMPT FROM G.F.A.			1196.2
G.F.A.			
PERMITTED/REQUIRED	PROPOSED		
AREA (SF)	AREA (M2)	AREA (SF)	AREA (M2)
TOTAL G.F.A.	SITE AREA x 90% (1710x 0.90)	1707.6	158.64
SITE COVERAGE - HOUSE			
PERMITTED/REQUIRED	PROPOSED		
AREA (SF)	AREA (M2)	AREA (SF)	AREA (M2)
AREA OF HOUSE		868.5	79.75
TOTAL SITE COVERAGE (MAX 25%)	1028	95.32	868.5
SITE COVERAGE - COMBINED			
PERMITTED/REQUIRED	PROPOSED		
AREA (SF)	AREA (M2)	AREA (SF)	AREA (M2)
AREA OF HOUSE		868.5	79.75
AREA OF ACCESSORY		249.7	23.20
TOTAL SITE COVERAGE (MAX 40%)	1368	127.09	249.7

PROJECT STATISTICS			
SITE STATISTICS			
CIVIC ADDRESS:		652 EAST 4TH ST NORTH VANCOUVER	
LEGAL DESCRIPTION:		LOT B OF LOT 16, BLOCK 18, DISTRICT LOT 273, PLAN 1083	
ZONE:		RS1	
SITE AREA (SQ FT):		3420	
SITE WIDTH (FT):		24.99	
PROJECT STATISTICS			
HOUSE		PERMITTED/REQUIRED	PROPOSED
		IMPERIAL	METRIC
ROOF HEIGHT	33.1	10.09	32.54
TOP PLATE	26.2	7.99	23.08
FRONT YARD SETBACK (S)	15	4.57	15
EAST SIDE YARD SETBACK	4	1.22	4
WEST SIDE YARD SETBACK	4	1.22	4
REAR YARD SETBACK (N)	47.89	14.60	60.19
ACCESSORY BUILDING		PERMITTED/REQUIRED	PROPOSED
		IMPERIAL	METRIC
BUILDING HEIGHT	10	3.05	11.4
FRONT YARD SETBACK TO HOUSE	2	0.61	2
EAST SIDE YARD SETBACK	2	0.61	2
WEST SIDE YARD SETBACK	4	1.22	4
REAR YARD SETBACK (N)	4	1.22	4

FLOOR AREAS			
FLOOR	PERMITTED/REQUIRED	PROPOSED	
	AREA (SF)	AREA (M2)	AREA (SF)
BASEMENT	86.5	79.75	
MAIN FLOOR	838.3	77.97	
2ND FLOOR	866.3	80.07	
ACCESSORY	249.7	23.20	
TOTAL SQ FT	1710	158.86	2815.8
G.F.A. EXEMPTIONS			
EXEMPTION	AREA (SF)	AREA (M2)	AREA (SF)
BASEMENT			86.5
ACCESSORY			249.7
TOTAL EXEMPT FROM G.F.A.			1196.2
G.F.A.			
PERMITTED/REQUIRED	PROPOSED		
AREA (SF)	AREA (M2)	AREA (SF)	AREA (M2)
TOTAL G.F.A.	SITE AREA x 90% (1710x 0.90)	1707.6	158.64
SITE COVERAGE - HOUSE			
PERMITTED/REQUIRED	PROPOSED		
AREA (SF)	AREA (M2)	AREA (SF)	AREA (M2)
AREA OF HOUSE		868.5	79.75
TOTAL SITE COVERAGE (MAX 25%)	1028	95.32	868.5
SITE COVERAGE - COMBINED			
PERMITTED/REQUIRED	PROPOSED		
AREA (SF)	AREA (M2)	AREA (SF)	AREA (M2)
AREA OF HOUSE		868.5	79.75
AREA OF ACCESSORY		249.7	23.20
TOTAL SITE COVERAGE (MAX 40%)	1368	127.09	249.7

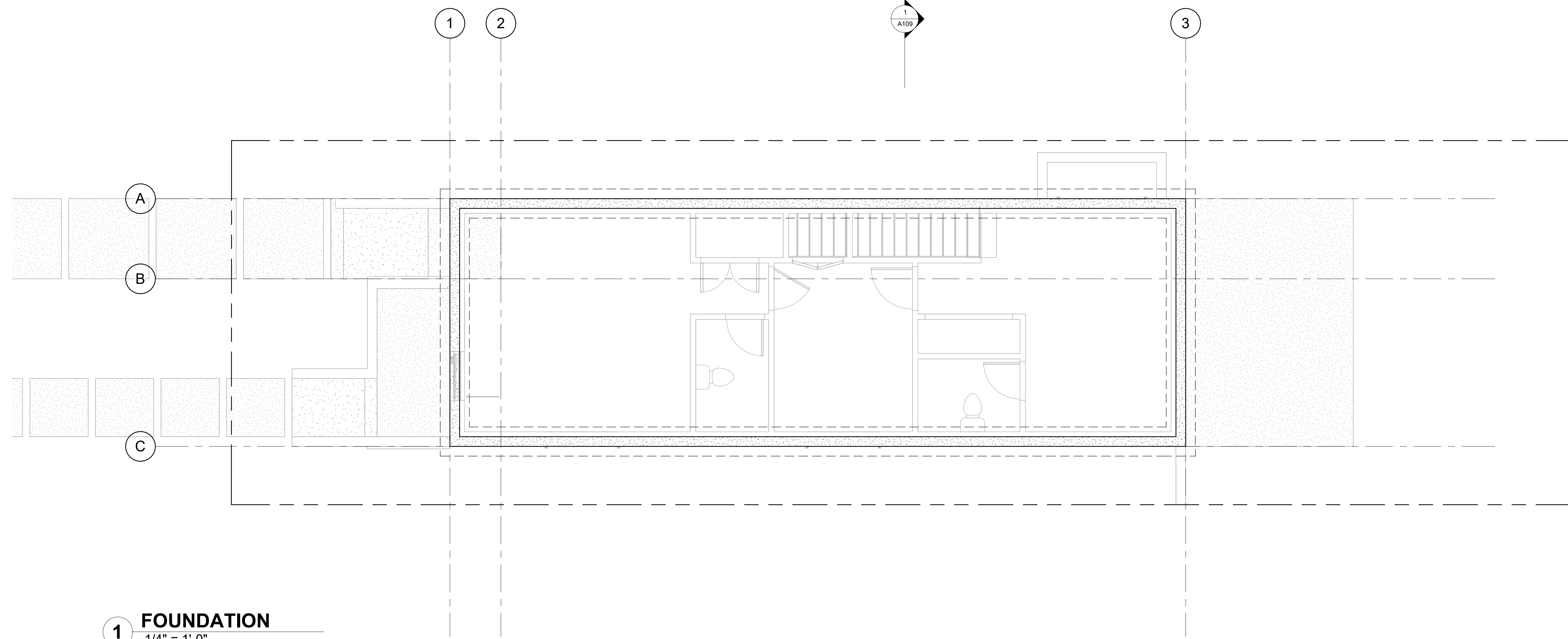

1 FOUNDATION
1/4" = 1'-0"



Window Schedule BASEMENT				
Level	Mark	Width	Height	Sill Height
BASEMENT	W13	5' - 0"	4' - 0"	5' - 0"
BASEMENT	W14	4' - 0"	4' - 0"	4' - 0"
BASEMENT	W15	5' - 0"	4' - 0"	5' - 0"
BASEMENT	W16	6' - 0"	4' - 0"	5' - 0"

Door Schedule BASEMENT			
Level	Mark	Width	Height
BASEMENT	16	2' - 10"	8' - 0"
BASEMENT	17	2' - 10"	8' - 0"
BASEMENT	18	2' - 6"	8' - 0"
BASEMENT	19	6' - 0"	8' - 0"
BASEMENT	20	2' - 6"	8' - 0"
BASEMENT	21	3' - 0"	8' - 0"
BASEMENT	22	4' - 0"	8' - 0"
BASEMENT	23	3' - 6"	6' - 8"

Room Schedule BASEMENT			
Level	Name	Area	Perimeter
BASEMENT	BATH	39 ft ²	25' - 5"
BASEMENT	BATH	35 ft ²	24' - 0"
BASEMENT	BED	110 ft ²	42' - 2"
BASEMENT	CLOSET	12 ft ²	14' - 1"
BASEMENT	DINING	55 ft ²	29' - 10"
BASEMENT	FLEX	186 ft ²	64' - 8 3/4"
BASEMENT	KITCHEN	65 ft ²	32' - 2"
BASEMENT	LAUNDRY/MECH	18 ft ²	18' - 1"
BASEMENT	LIVING	70 ft ²	33' - 6 1/2"
BASEMENT	MECH	16 ft ²	18' - 8"

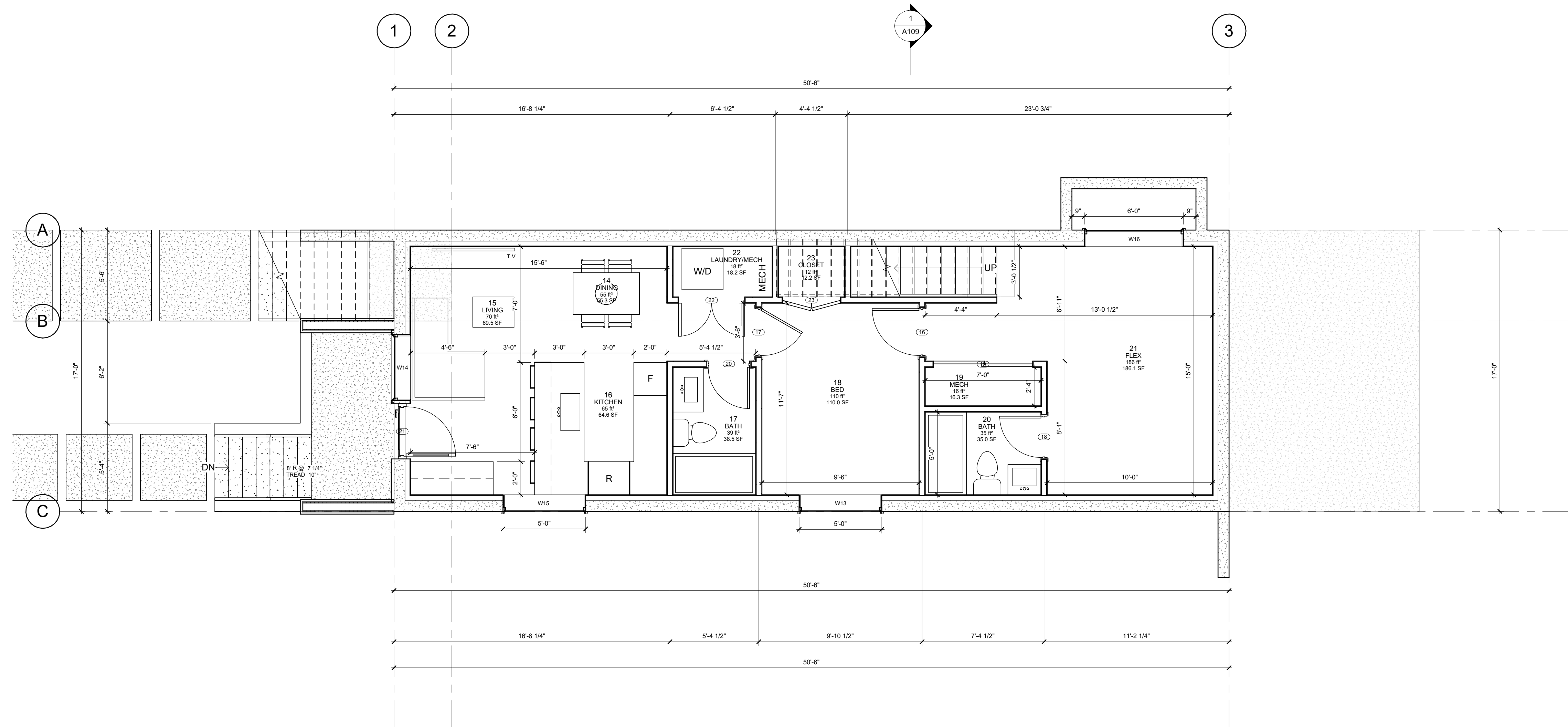

1 BASEMENT
1/4" = 1'-0"



5464 PATRICIA BAY HIGHWAY,
VICTORIA BC V8Y 2N9

(604) 626-6020
ROBERTBLANEYDESIGN@GMAIL.COM
WWW.ROBERTBLANEYDESIGN.COM

REVISIONS
ISSUED FOR: IFR
REVIEW SET: 03/06/21

PROJECT:
LOT A
652 EAST 4TH ST.
NORTH VANCOUVER

DRAWING TITLE:
BASEMENT FLOOR PLAN

SHEET:
A102

DRAWN BY:
JP

24X36 SCALE:
1/4" = 1'-0"

START DATE:
05.03.23

PROJECT NUMBER:
Project Number

COPYRIGHT RESERVED.

THIS DRAWING AND DESIGN ARE AND SHALL AT ALL TIMES REMAIN THE EXCLUSIVE PROPERTY OF ROBERT BLANEY DESIGN AND CANNOT BE USED OR REPRODUCED WITHOUT WRITTEN CONSENT. WRITTEN DIMENSIONS SHALL HAVE PRECEDENCE OVER SCALED DIMENSIONS. CONTRACTOR SHALL VERIFY AND SHALL BE RESPONSIBLE FOR ALL DIMENSIONS AND CONDITIONS ON THE JOB AND THIS OFFICE SHALL BE INFORMED OF ANY VARIATIONS FROM THE DIMENSIONS AND CONDITIONS AS SHOWN ON THIS DRAWING. CONTRACTORS SHALL ENSURE THAT ALL CONSTRUCTION WILL COMPLY TO ALL APPLICABLE BUILDING CODES. ROBERT BLANEY DESIGN WILL NOT ACCEPT RESPONSIBILITY FOR VARIATIONS OR MODIFICATION OF THESE PLANS.



Window Schedule MAIN FLOOR				
Level	Mark	Width	Height	Sill Height
MAIN FLOOR	S1	4' - 0"	4' - 0"	
MAIN FLOOR	S2	4' - 0"	4' - 0"	
MAIN FLOOR	W2	3' - 0"	7' - 0"	3' - 0"
MAIN FLOOR	W3	3' - 0"	7' - 0"	3' - 0"
MAIN FLOOR	W4	7' - 6"	7' - 6"	0' - 6"
MAIN FLOOR	W5	2' - 0"	4' - 0"	4' - 0"
MAIN FLOOR	W6	2' - 6"	6' - 0"	2' - 0"
MAIN FLOOR	W7	2' - 6"	6' - 0"	2' - 0"

Door Schedule MAIN FLOOR			
Level	Mark	Width	Height
MAIN FLOOR	2	2' - 6"	8' - 0"
MAIN FLOOR	3	4' - 0"	8' - 0"
MAIN FLOOR	4	3' - 0"	8' - 0"
MAIN FLOOR	5	10' - 0"	8' - 0"

Room Schedule MAIN FLOOR			
Level	Name	Area	Perimeter
MAIN FLOOR	FAMILY	192 ft ²	61' - 10 1/4"
MAIN FLOOR	KITCHEN	162 ft ²	50' - 3 1/4"
MAIN FLOOR	DINING	130 ft ²	45' - 8"
MAIN FLOOR	POWDER	27 ft ²	20' - 8"
MAIN FLOOR	FOYER	40 ft ²	25' - 9 1/4"
MAIN FLOOR	LIVING	116 ft ²	43' - 1 1/4"

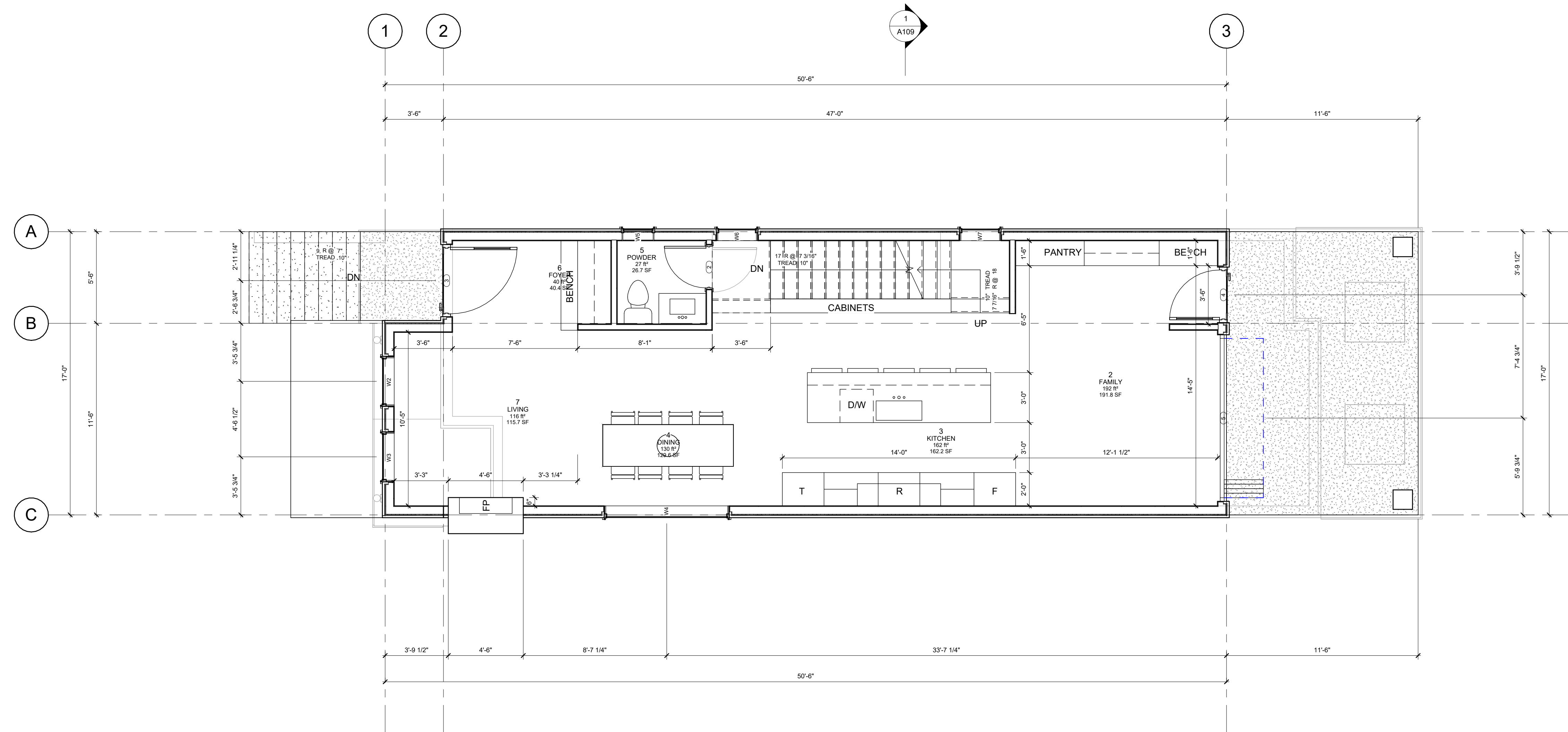

1 MAIN FLOOR
1/4" = 1'-0"



5464 PATRICIA BAY HIGHWAY,
VICTORIA BC V8Y 2N9

(604) 626-6020
ROBERTBLANEYDESIGN@GMAIL.COM
WWW.ROBERTBLANEYDESIGN.COM

REVISIONS
ISSUED FOR: IFR
REVIEW SET: 03/06/21

PROJECT:
LOT A
652 EAST 4TH ST.
NORTH VANCOUVER

DRAWING TITLE:
MAIN FLOOR PLAN

SHEET:

A103

DRAWN BY:

JP

24X36 SCALE:
1/4" = 1'-0"

PROJECT NUMBER:
Project Number

START DATE:
05.03.23

COPYRIGHT RESERVED.

THIS DRAWING AND DESIGN ARE AND SHALL AT ALL TIMES REMAIN THE EXCLUSIVE PROPERTY OF ROBERT BLANEY DESIGN AND CANNOT BE USED OR REPRODUCED WITHOUT WRITTEN CONSENT. WRITTEN DIMENSIONS SHALL HAVE PRECEDENCE OVER SCALED DIMENSIONS. CONTRACTOR SHALL VERIFY AND SHALL BE RESPONSIBLE FOR ALL DIMENSIONS AND CONDITIONS ON THE JOB AND THIS OFFICE SHALL BE INFORMED OF ANY VARIATIONS FROM THE DIMENSIONS AND CONDITIONS AS SHOWN ON THIS DRAWING. CONTRACTORS SHALL ENSURE THAT ALL CONSTRUCTION WILL COMPLY TO ALL APPLICABLE BUILDING CODES. ROBERT BLANEY DESIGN WILL NOT ACCEPT RESPONSIBILITY FOR VARIATIONS OR MODIFICATION OF THESE PLANS.

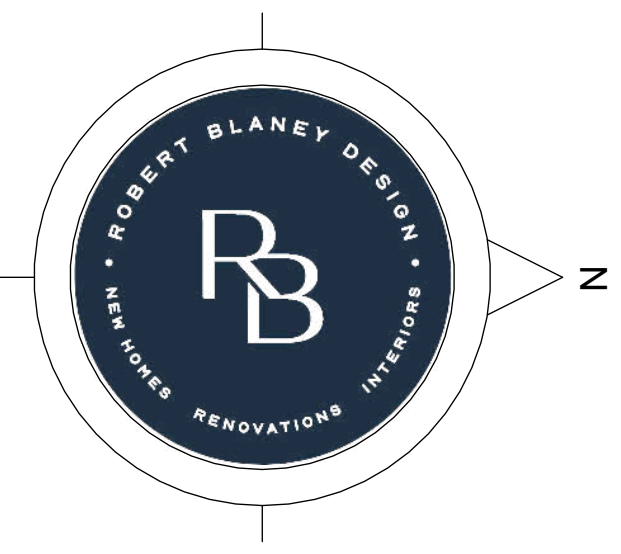

Window Schedule 2ND FLOOR				
Level	Mark	Width	Height	Sill Height
2ND FLOOR	W8	5' - 0"	7' - 0"	3' - 0"
2ND FLOOR	W9	6' - 0"	6' - 0"	2' - 0"
2ND FLOOR	W10	4' - 0"	4' - 0"	4' - 0"
2ND FLOOR	W11	5' - 0"	5' - 0"	3' - 0"
2ND FLOOR	W12	3' - 0"	5' - 0"	3' - 0"
2ND FLOOR	W17	2' - 0"	4' - 0"	4' - 0"

Door Schedule 2ND FLOOR			
Level	Mark	Width	Height
2ND FLOOR	6	2' - 10"	6' - 8"
2ND FLOOR	7	2' - 10"	6' - 8"
2ND FLOOR	8	2' - 10"	6' - 8"
2ND FLOOR	9	2' - 2"	6' - 8"
2ND FLOOR	10	2' - 6"	6' - 8"
2ND FLOOR	11	2' - 6"	6' - 8"
2ND FLOOR	12	2' - 6"	6' - 8"
2ND FLOOR	13	2' - 8"	6' - 8"
2ND FLOOR	14	2' - 8"	6' - 8"
2ND FLOOR	15	2' - 6"	6' - 8"

Room Schedule 2ND FLOOR			
Level	Name	Area	Perimeter
2ND FLOOR	BATH	50 ft ²	30' - 0"
2ND FLOOR	BED 1	134 ft ²	55' - 8"
2ND FLOOR	BED 2	119 ft ²	43' - 11"
2ND FLOOR	ENSUITE	80 ft ²	47' - 5"
2ND FLOOR	PRIMARY	146 ft ²	51' - 10 3/4"
2ND FLOOR	W.I.C	51 ft ²	30' - 4 1/2"

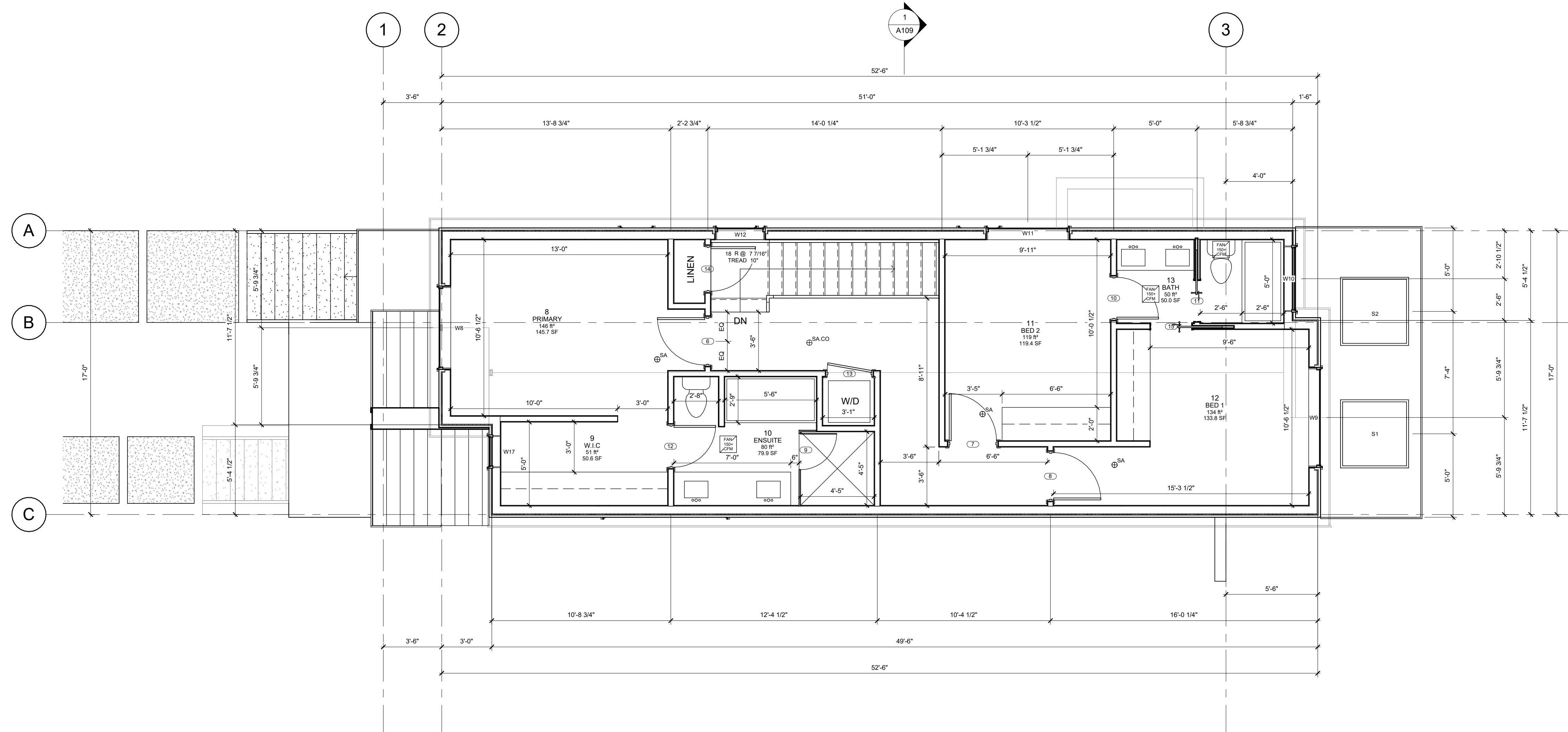

1 2ND FLOOR
1/4" = 1'-0"



5464 PATRICIA BAY HIGHWAY,
VICTORIA BC V8Y 2N9

(604) 626-6020
ROBERTBLANEYDESIGN@GMAIL.COM
WWW.ROBERTBLANEYDESIGN.COM

REVISIONS
ISSUED FOR: IFR
REVIEW SET: 05/24/21

PROJECT:
LOT A
652 EAST 4TH ST.
NORTH VANCOUVER

DRAWING TITLE:
2ND FLOOR PLAN

SHEET:
A104

DRAWN BY: JP
24X36 SCALE: 1/4" = 1'-0"
START DATE: 05.03.23

PROJECT NUMBER:
Project Number

COPYRIGHT RESERVED.
THIS DRAWING AND DESIGN ARE AND SHALL AT ALL TIMES REMAIN THE EXCLUSIVE PROPERTY OF ROBERT BLANEY DESIGN AND CANNOT BE USED OR REPRODUCED WITHOUT WRITTEN CONSENT. WRITTEN DIMENSIONS SHALL HAVE PRECEDENCE OVER SCALED DIMENSIONS. CONTRACTOR SHALL VERIFY AND SHALL BE RESPONSIBLE FOR ALL DIMENSIONS AND CONDITIONS ON THE JOB AND THIS OFFICE SHALL BE INFORMED OF ANY VARIATIONS FROM THE DIMENSIONS AND CONDITIONS AS SHOWN ON THIS DRAWING. CONTRACTORS SHALL ENSURE THAT ALL CONSTRUCTION WILL COMPLY TO ALL APPLICABLE BUILDING CODES. ROBERT BLANEY DESIGN WILL NOT ACCEPT RESPONSIBILITY FOR VARIATIONS OR MODIFICATION OF THESE PLANS.

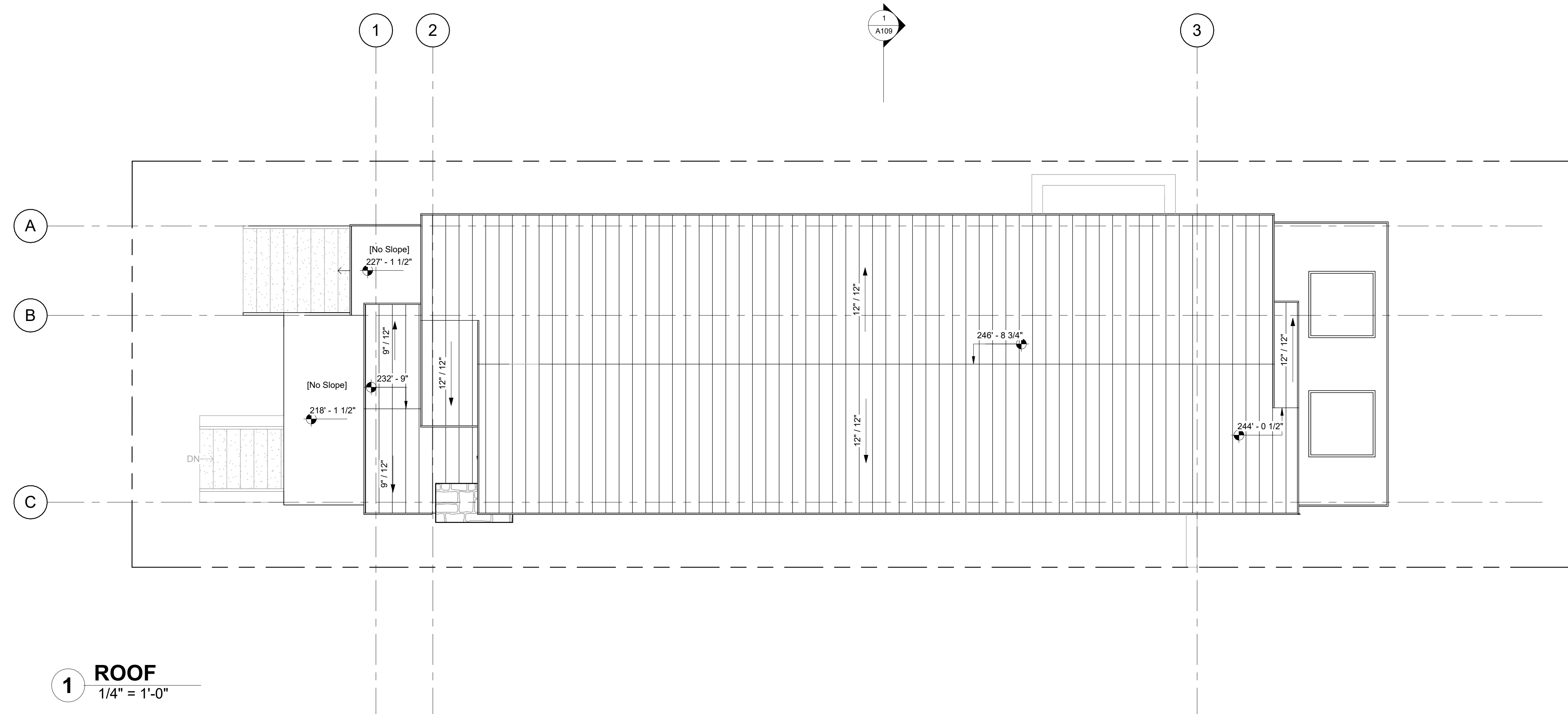

1 ROOF
1/4" = 1'-0"



5464 PATRICIA BAY HIGHWAY,
VICTORIA BC V8Y 2N9

(604) 626-6020
ROBERTBLANEYDESIGN@GMAIL.COM
WWW.ROBERTBLANEYDESIGN.COM

REVISIONS
ISSUED FOR: IFR
REVIEW SET: 03/06/21

PROJECT:
LOT A
652 EAST 4TH ST.
NORTH VANCOUVER

DRAWING TITLE:
ROOF PLAN

SHEET:
A105

DRAWN BY:
JP

24X36 SCALE:
1/4" = 1'-0"

START DATE:
05.03.23

PROJECT NUMBER:
Project Number

COPYRIGHT RESERVED.

THIS DRAWING AND DESIGN ARE AND SHALL AT ALL TIMES REMAIN THE EXCLUSIVE PROPERTY OF ROBERT BLANEY DESIGN AND CANNOT BE USED OR REPRODUCED WITHOUT WRITTEN CONSENT. WRITTEN DIMENSIONS SHALL HAVE PRECEDENCE OVER SCALED DIMENSIONS. CONTRACTOR SHALL VERIFY AND SHALL BE RESPONSIBLE FOR ALL DIMENSIONS AND CONDITIONS ON THE JOB AND THIS OFFICE SHALL BE INFORMED OF ANY VARIATIONS FROM THE DIMENSIONS AND CONDITIONS AS SHOWN ON THIS DRAWING. CONTRACTORS SHALL ENSURE THAT ALL CONSTRUCTION WILL COMPLY TO ALL APPLICABLE BUILDING CODES. ROBERT BLANEY DESIGN WILL NOT ACCEPT RESPONSIBILITY FOR VARIATIONS OR MODIFICATION OF THESE PLANS.



Window Schedule ALL FLOORS					
Level	Mark	Sill Height	Width	Height	Area
MAIN FLOOR	S1		4' - 0"	4' - 0"	16 ft ²
MAIN FLOOR	S2		4' - 0"	4' - 0"	16 ft ²
MAIN FLOOR	W2	3' - 0"	3' - 0"	7' - 0"	21 ft ²
MAIN FLOOR	W3	3' - 0"	3' - 0"	7' - 0"	21 ft ²
MAIN FLOOR	W4	0' - 6"	7' - 6"	7' - 6"	56 ft ²
MAIN FLOOR	W5	4' - 0"	2' - 0"	4' - 0"	8 ft ²
MAIN FLOOR	W6	2' - 0"	2' - 6"	6' - 0"	15 ft ²
MAIN FLOOR	W7	2' - 0"	2' - 6"	6' - 0"	15 ft ²
2ND FLOOR	W8	3' - 0"	5' - 0"	7' - 0"	35 ft ²
2ND FLOOR	W9	2' - 0"	6' - 0"	6' - 0"	36 ft ²
2ND FLOOR	W10	4' - 0"	4' - 0"	4' - 0"	16 ft ²
2ND FLOOR	W11	3' - 0"	5' - 0"	5' - 0"	25 ft ²
2ND FLOOR	W12	3' - 0"	3' - 0"	5' - 0"	15 ft ²
BASEMENT	W13	5' - 0"	5' - 0"	4' - 0"	20 ft ²
BASEMENT	W14	4' - 0"	4' - 0"	4' - 0"	16 ft ²
BASEMENT	W15	5' - 0"	5' - 0"	4' - 0"	20 ft ²
BASEMENT	W16	5' - 0"	6' - 0"	4' - 0"	24 ft ²
2ND FLOOR	W17	4' - 0"	2' - 0"	4' - 0"	8 ft ²

Door Schedule EXTERIOR					
Level	Mark	Width	Height	Function	
MAIN FLOOR	3	4' - 0"	8' - 0"	Exterior	
MAIN FLOOR	4	3' - 0"	8' - 0"	Exterior	
BASEMENT	21	3' - 0"	8' - 0"	Exterior	
GARAGE SLAB	25	3' - 0"	6' - 8"	Exterior	

LEGEND	
BOARD & BATTEN (WHITE)	A
BOARD & BATTEN (BROWN)	B
HORIZONTAL CEDAR (BROWN)	C
STONE (TBD)	D
STANDING SEAM METAL (CHARCOAL)	E



5464 PATRICIA BAY HIGHWAY,
VICTORIA BC V8Y 2N9

(604) 626-6020
ROBERTBLANEYDESIGN@GMAIL.COM
WWW.ROBERTBLANEYDESIGN.COM

REVISIONS
ISSUED FOR: IFR
REVIEW SET: 03/06/21

PROJECT:
LOT A
652 EAST 4TH ST.
NORTH VANCOUVER

DRAWING TITLE:
ELEVATIONS - NORTH &
SOUTH

SHEET:

A106

DRAWN BY:
JP

24X36 SCALE:
1/4" = 1'-0"

START DATE:
05.03.23

PROJECT NUMBER:
Project
Number

COPYRIGHT RESERVED.

THIS DRAWING AND DESIGN ARE AND SHALL AT ALL TIMES REMAIN THE EXCLUSIVE PROPERTY OF ROBERT BLANEY DESIGN AND CANNOT BE USED OR REPRODUCED WITHOUT WRITTEN CONSENT. WRITTEN DIMENSIONS SHALL HAVE PRECEDENCE OVER SCALED DIMENSIONS. CONTRACTOR SHALL VERIFY AND SHALL BE RESPONSIBLE FOR ALL DIMENSIONS AND CONDITIONS ON THE JOB AND THIS OFFICE SHALL BE INFORMED OF ANY VARIATIONS FROM THE DIMENSIONS AND CONDITIONS AS SHOWN ON THIS DRAWING. CONTRACTORS SHALL ENSURE THAT ALL CONSTRUCTION WILL COMPLY TO ALL APPLICABLE BUILDING CODES. ROBERT BLANEY DESIGN WILL NOT ACCEPT RESPONSIBILITY FOR VARIATIONS OR MODIFICATION OF THESE PLANS.

Window Schedule ALL FLOORS					
Level	Mark	Sill Height	Width	Height	Area
MAIN FLOOR	S1		4' - 0"	4' - 0"	16 ft²
MAIN FLOOR	S2		4' - 0"	4' - 0"	16 ft²
MAIN FLOOR	W2	3' - 0"	3' - 0"	7' - 0"	21 ft²
MAIN FLOOR	W3	3' - 0"	3' - 0"	7' - 0"	21 ft²
MAIN FLOOR	W4	0' - 6"	7' - 6"	7' - 6"	56 ft²
MAIN FLOOR	W5	4' - 0"	2' - 0"	4' - 0"	8 ft²
MAIN FLOOR	W6	2' - 0"	2' - 6"	6' - 0"	15 ft²
MAIN FLOOR	W7	2' - 0"	2' - 6"	6' - 0"	15 ft²
2ND FLOOR	W8	3' - 0"	5' - 0"	7' - 0"	35 ft²
2ND FLOOR	W9	2' - 0"	6' - 0"	6' - 0"	36 ft²
2ND FLOOR	W10	4' - 0"	4' - 0"	4' - 0"	16 ft²
2ND FLOOR	W11	3' - 0"	5' - 0"	5' - 0"	25 ft²
2ND FLOOR	W12	3' - 0"	3' - 0"	5' - 0"	15 ft²
BASEMENT	W13	5' - 0"	5' - 0"	4' - 0"	20 ft²
BASEMENT	W14	4' - 0"	4' - 0"	4' - 0"	16 ft²
BASEMENT	W15	5' - 0"	5' - 0"	4' - 0"	20 ft²
BASEMENT	W16	5' - 0"	6' - 0"	4' - 0"	24 ft²
2ND FLOOR	W17	4' - 0"	2' - 0"	4' - 0"	8 ft²

Door Schedule EXTERIOR				
Level	Mark	Width	Height	Function
MAIN FLOOR	3	4' - 0"	8' - 0"	Exterior
MAIN FLOOR	4	3' - 0"	8' - 0"	Exterior
BASEMENT	21	3' - 0"	8' - 0"	Exterior
GARAGE SLAB	25	3' - 0"	6' - 8"	Exterior

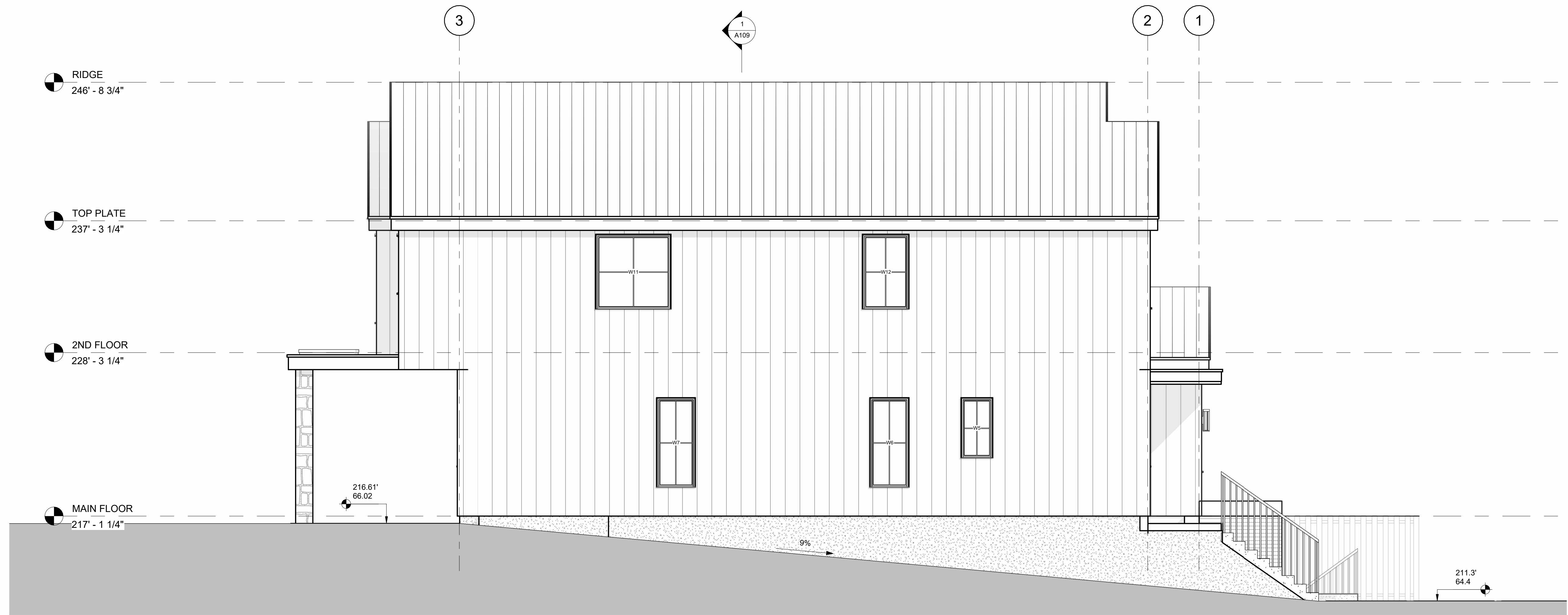

1 WEST
1/4" = 1'-0"

LEGEND	
BOARD & BATTEN (WHITE)	A
BOARD & BATTEN (BROWN)	B
HORIZONTAL CEDAR (BROWN)	C
STONE (TBD)	D
STANDING SEAM METAL (CHARCOAL)	E



5464 PATRICIA BAY HIGHWAY,
VICTORIA BC V8Y 2N9

(604) 626-6020
ROBERTBLANEYDESIGN@GMAIL.COM
WWW.ROBERTBLANEYDESIGN.COM

REVISIONS
ISSUED FOR: IFR
REVIEW SET: 03/06/21

PROJECT:
LOT A
652 EAST 4TH ST.
NORTH VANCOUVER

DRAWING TITLE:
ELEVATIONS - WEST

SHEET:
A107

DRAWN BY: JP

24X36 SCALE: 1/4" = 1'-0"

START DATE: 05.03.23

PROJECT NUMBER: Project Number

COPYRIGHT RESERVED.
THIS DRAWING AND DESIGN ARE AND SHALL AT ALL TIMES REMAIN THE EXCLUSIVE PROPERTY OF ROBERT BLANEY DESIGN AND CANNOT BE USED OR REPRODUCED WITHOUT WRITTEN CONSENT. WRITTEN DIMENSIONS SHALL HAVE PRECEDENCE OVER SCALED DIMENSIONS. CONTRACTOR SHALL VERIFY AND SHALL BE RESPONSIBLE FOR ALL DIMENSIONS AND CONDITIONS ON THE JOB AND THIS OFFICE SHALL BE INFORMED OF ANY VARIATIONS FROM THE DIMENSIONS AND CONDITIONS AS SHOWN ON THIS DRAWING. CONTRACTORS SHALL ENSURE THAT ALL CONSTRUCTION WILL COMPLY TO ALL APPLICABLE BUILDING CODES. ROBERT BLANEY DESIGN WILL NOT ACCEPT RESPONSIBILITY FOR VARIATIONS OR MODIFICATION OF THESE PLANS.

Window Schedule ALL FLOORS					
Level	Mark	Sill Height	Width	Height	Area
MAIN FLOOR	S1		4' - 0"	4' - 0"	16 ft²
MAIN FLOOR	S2		4' - 0"	4' - 0"	16 ft²
MAIN FLOOR	W2	3' - 0"	3' - 0"	7' - 0"	21 ft²
MAIN FLOOR	W3	3' - 0"	3' - 0"	7' - 0"	21 ft²
MAIN FLOOR	W4	0' - 6"	7' - 6"	7' - 6"	56 ft²
MAIN FLOOR	W5	4' - 0"	2' - 0"	4' - 0"	8 ft²
MAIN FLOOR	W6	2' - 0"	2' - 6"	6' - 0"	15 ft²
MAIN FLOOR	W7	2' - 0"	2' - 6"	6' - 0"	15 ft²
2ND FLOOR	W8	3' - 0"	5' - 0"	7' - 0"	35 ft²
2ND FLOOR	W9	2' - 0"	6' - 0"	6' - 0"	36 ft²
2ND FLOOR	W10	4' - 0"	4' - 0"	4' - 0"	16 ft²
2ND FLOOR	W11	3' - 0"	5' - 0"	5' - 0"	25 ft²
2ND FLOOR	W12	3' - 0"	3' - 0"	5' - 0"	15 ft²
BASEMENT	W13	5' - 0"	5' - 0"	4' - 0"	20 ft²
BASEMENT	W14	4' - 0"	4' - 0"	4' - 0"	16 ft²
BASEMENT	W15	5' - 0"	5' - 0"	4' - 0"	20 ft²
BASEMENT	W16	5' - 0"	6' - 0"	4' - 0"	24 ft²
2ND FLOOR	W17	4' - 0"	2' - 0"	4' - 0"	8 ft²

Door Schedule EXTERIOR				
Level	Mark	Width	Height	Function
MAIN FLOOR	3	4' - 0"	8' - 0"	Exterior
MAIN FLOOR	4	3' - 0"	8' - 0"	Exterior
BASEMENT	21	3' - 0"	8' - 0"	Exterior
GARAGE SLAB	25	3' - 0"	6' - 8"	Exterior

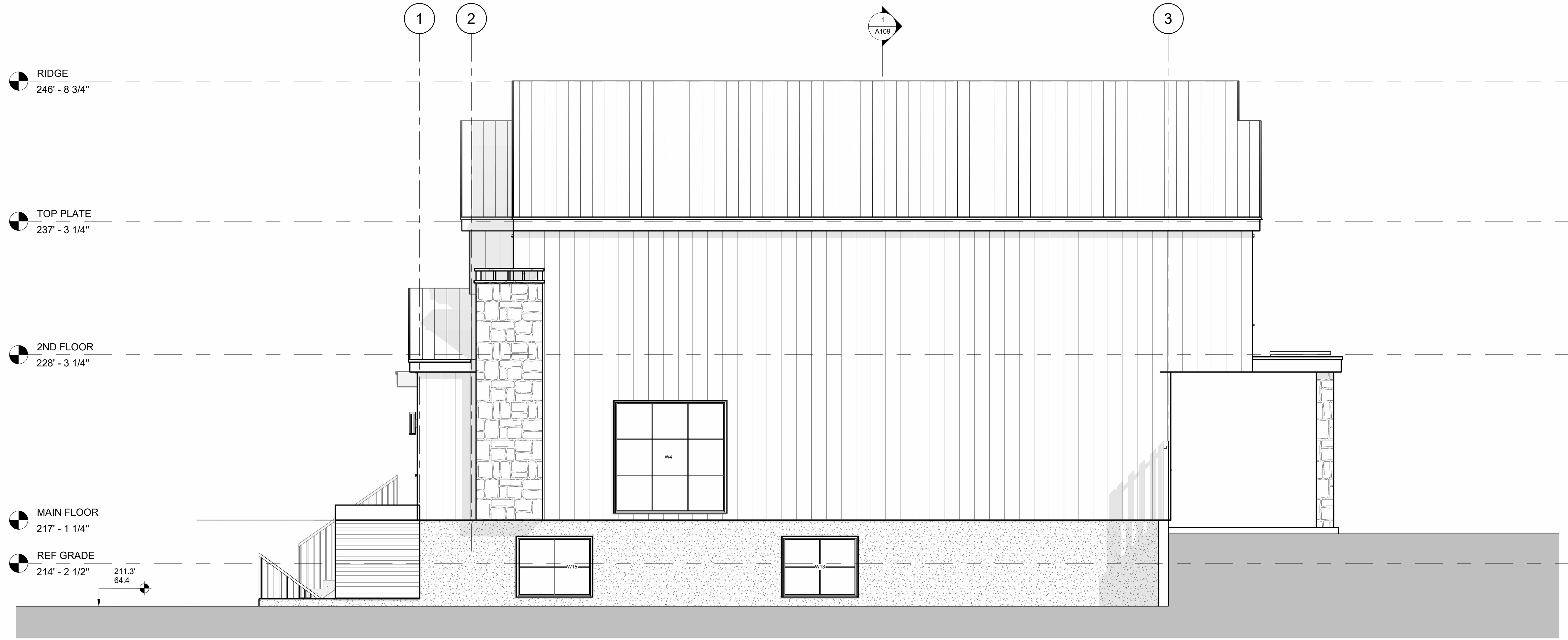

1 EAST
1/4" = 1'-0"

LEGEND	
BOARD & BATTEN (WHITE)	A
BOARD & BATTEN (BROWN)	B
HORIZONTAL CEDAR (BROWN)	C
STONE (TBD)	D
STANDING SEAM METAL (CHARCOAL)	E



5464 PATRICIA BAY HIGHWAY,
VICTORIA BC V8Y 2N9

(604) 626-6020
ROBERTBLANEYDESIGN@GMAIL.COM
WWW.ROBERTBLANEYDESIGN.COM

REVISIONS
ISSUED FOR: IFR
REVIEW SET: 05/03/23

PROJECT:
LOT A
652 EAST 4TH ST.
NORTH VANCOUVER

DRAWING TITLE:
ELEVATIONS - EAST

SHEET:
A108

DRAWN BY: JP
24X36 SCALE: 1/4" = 1'-0"
START DATE: 05.03.23
PROJECT NUMBER: Project Number

COPYRIGHT RESERVED.
THIS DRAWING AND DESIGN ARE AND SHALL AT ALL TIMES REMAIN THE EXCLUSIVE PROPERTY OF ROBERT BLANEY DESIGN AND CANNOT BE USED OR REPRODUCED WITHOUT WRITTEN CONSENT. WRITTEN DIMENSIONS SHALL HAVE PRECEDENCE OVER SCALED DIMENSIONS. CONTRACTOR SHALL VERIFY AND SHALL BE RESPONSIBLE FOR ALL DIMENSIONS AND CONDITIONS ON THE JOB AND THIS OFFICE SHALL BE INFORMED OF ANY VARIATIONS FROM THE DIMENSIONS AND CONDITIONS AS SHOWN ON THIS DRAWING. CONTRACTORS SHALL ENSURE THAT ALL CONSTRUCTION WILL COMPLY TO ALL APPLICABLE BUILDING CODES. ROBERT BLANEY DESIGN WILL NOT ACCEPT RESPONSIBILITY FOR VARIATIONS OR MODIFICATION OF THESE PLANS.

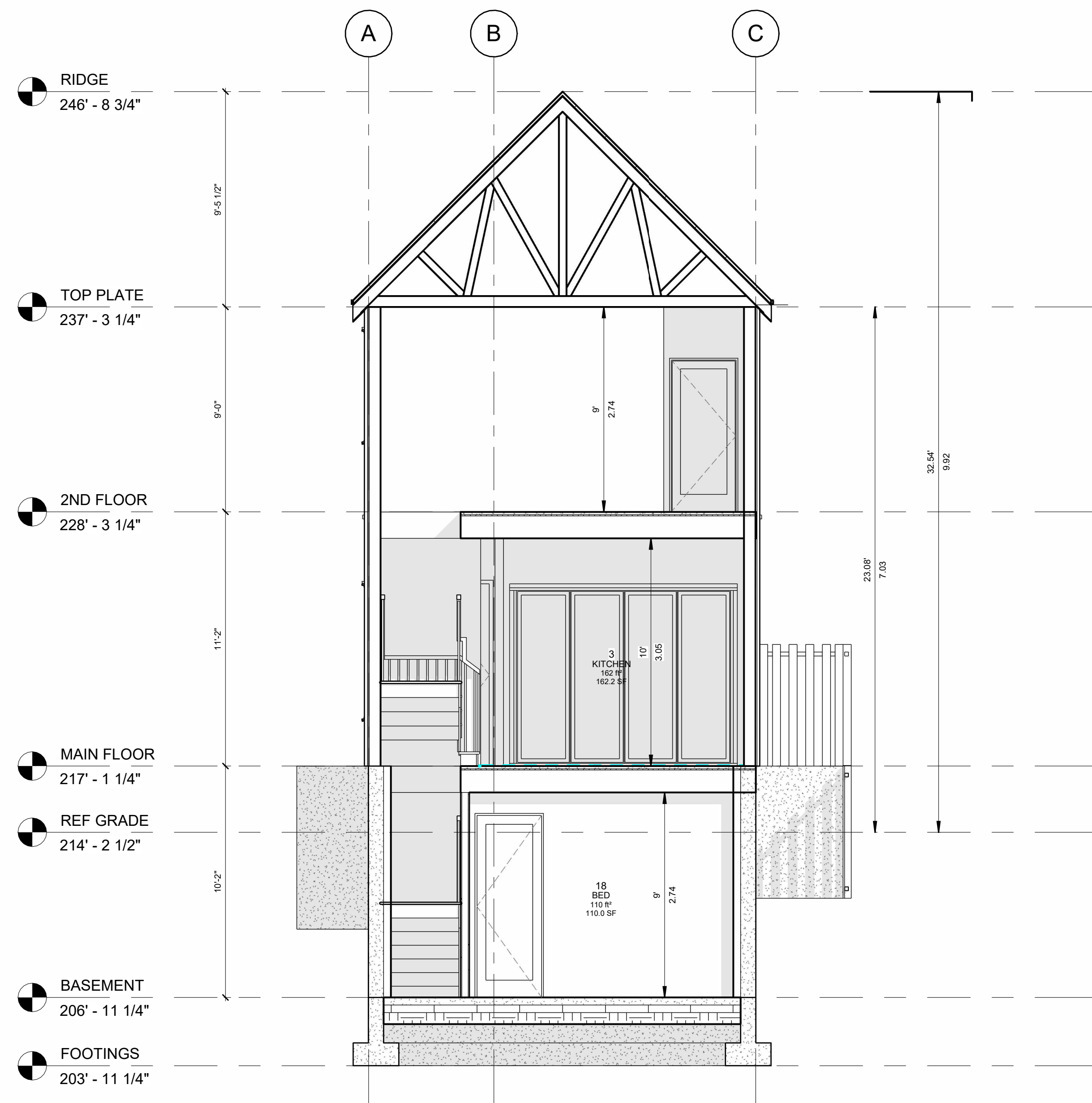

W1 EXTERIOR WALL (ABOVE GRADE)

CLADDING
 1/2" PURLINS OR RAIN-SCREEN SYSTEM
 2" XPS RIGID INSUL.
 TYVEK SEALED & TAPED
 1/2" PLYWOOD SHEATHING
 2X6" STUDS @ 16" O.C
 BATT INSULATION (R22)
 6MIL POLY V.B
 1/2" G.W.B PAINTED
 AIR FILM (INTERIOR)

W2 FURRED FOUNDATION WALL

DRAINAGE MAT W/ FILTER FABRIC
 2 COATS OF BITUMINOUS SEALANT
 8" FOUNDATION WALL
 2X4" STUDS @ 16" O.C
 BATT INSULATION (R22)
 6MIL POLY V.B.
 1/2" G.W.B
 AIR FILM (INTERIOR)

W3 FOUNDATION WALL

DRAINAGE MAT W/ FILTER FABRIC
 2 COATS OF BITUMINOUS SEALANT
 8" CONCRETE WALL

W4 INTERIOR WALL - 2x6"

1/2" G.W.B BOTH SIDES
 2X6" STUDS @ 16" O.C

F1 FLOOR OVER CONDITIONED SPACE

FLOOR FINISH
 1-1/2" CONCRETE TOPPING
 3/4" T&G FLOOR SHEATHING GLUED & SCREWED
 11-7/8" TJI JOISTS @ 12" O.C
 1/2" G.W.B PAINTED

F2 FLOOR OVER UNCONDITIONED SPACE

FLOOR FINISH
 1-1/2" CONCRETE TOPPING
 3/4" T&G FLOOR SHEATHING GLUED & SCREWED
 11-7/8" TJI JOISTS @ 16" O.C
 SPRAY FOAM CLOSED CELL INSUL (R28)

F3 BASEMENT SLAB

FLOOR FINISH
 4" REINFORCED CONCRETE SLAB
 6MIL POLY V.B
 3" RIGID INSULATION UNDER SLAB (R16)
 6" MIN. COMPACTED GRANULAR BASE
 RADON GAS VENTED

F4 PATIO SLAB/DRIVEWAY ON GRADE

4" REINFORCED CONCRETE SLAB
 6" MIN. COMPACTED GRANULAR BASE

R1 TRUSS ROOF

STANDING SEAM METAL
 UNDERLAYMENT
 3/4" ROOF SHAETHING
 2X4" CROSS STRAPPING @ 24" O.C
 ENGINEERED TRUSSES @ 24" O.C
 BLOWN INSULATION (R50)
 6MIL POLY V.B. TAPED AND SEALED
 1/2" G.W.B PAINTED
 AIR FILM (INTERIOR)

R2 FLAT ROOF

2 LAYERS TORCH ON ROOFING
 3/4" ROOF SHAETHING
 2X4" CROSS STRAPPING @ 16" O.C
 16" TGI RAFTERS @ 16" O.C
 BATT INSULATION (R28)
 6MIL POLY V.B. TAPED AND SEALED
 1/2" G.W.B PAINTED
 AIR FILM (INTERIOR)

1 Section 1
 1/4" = 1'-0"



5464 PATRICIA BAY HIGHWAY,
 VICTORIA BC V8Y 2N9
 (604) 626-6020
 ROBERTBLANEYDESIGN@GMAIL.COM
 WWW.ROBERTBLANEYDESIGN.COM

REVISIONS
 ISSUED FOR: IFR
 REVIEW SET: 03/07/21

PROJECT:
 LOT A
 652 EAST 4TH ST.
 NORTH VANCOUVER

DRAWING TITLE:
**SECTIONS &
 ASSEMBLIES**

SHEET:
A109

DRAWN BY: JP
 24X36 SCALE: 1/4" = 1'-0"
 PROJECT NUMBER: Project Number
 START DATE: 05.03.23

COPYRIGHT RESERVED.
 THIS DRAWING AND DESIGN ARE AND SHALL AT ALL TIMES REMAIN THE EXCLUSIVE PROPERTY OF ROBERT BLANEY DESIGN AND CANNOT BE USED OR REPRODUCED WITHOUT WRITTEN CONSENT. WRITTEN DIMENSIONS SHALL HAVE PRECEDENCE OVER SCALED DIMENSIONS. CONTRACTOR SHALL VERIFY AND SHALL BE RESPONSIBLE FOR ALL DIMENSIONS AND CONDITIONS ON THE JOB AND THIS OFFICE SHALL BE INFORMED OF ANY VARIATIONS FROM THE DIMENSIONS AND CONDITIONS AS SHOWN ON THIS DRAWING. CONTRACTORS SHALL ENSURE THAT ALL CONSTRUCTION WILL COMPLY TO ALL APPLICABLE BUILDING CODES. ROBERT BLANEY DESIGN WILL NOT ACCEPT RESPONSIBILITY FOR VARIATIONS OR MODIFICATION OF THESE PLANS.

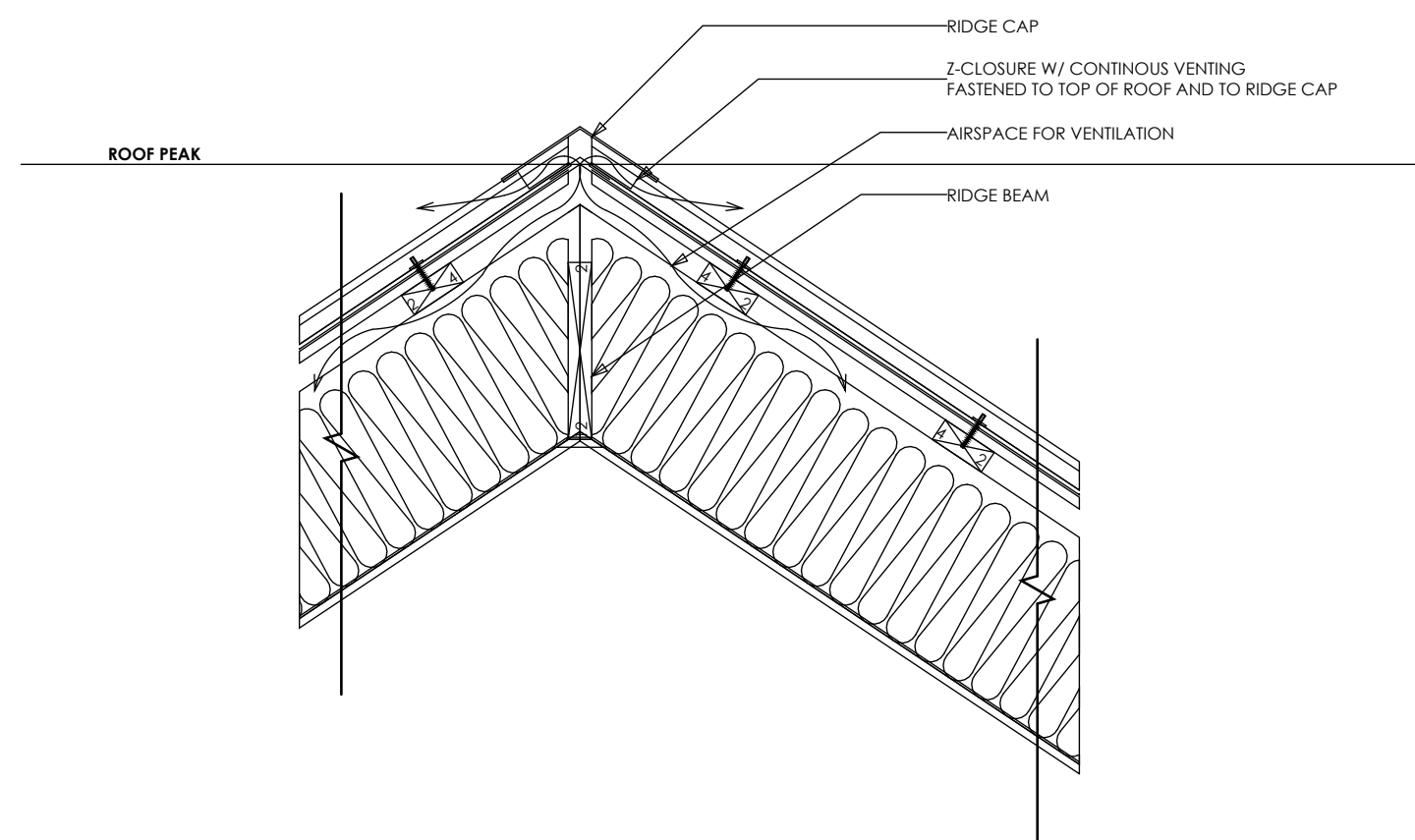

9 RIDGE VENTING - VAULT
1" = 1'-0"

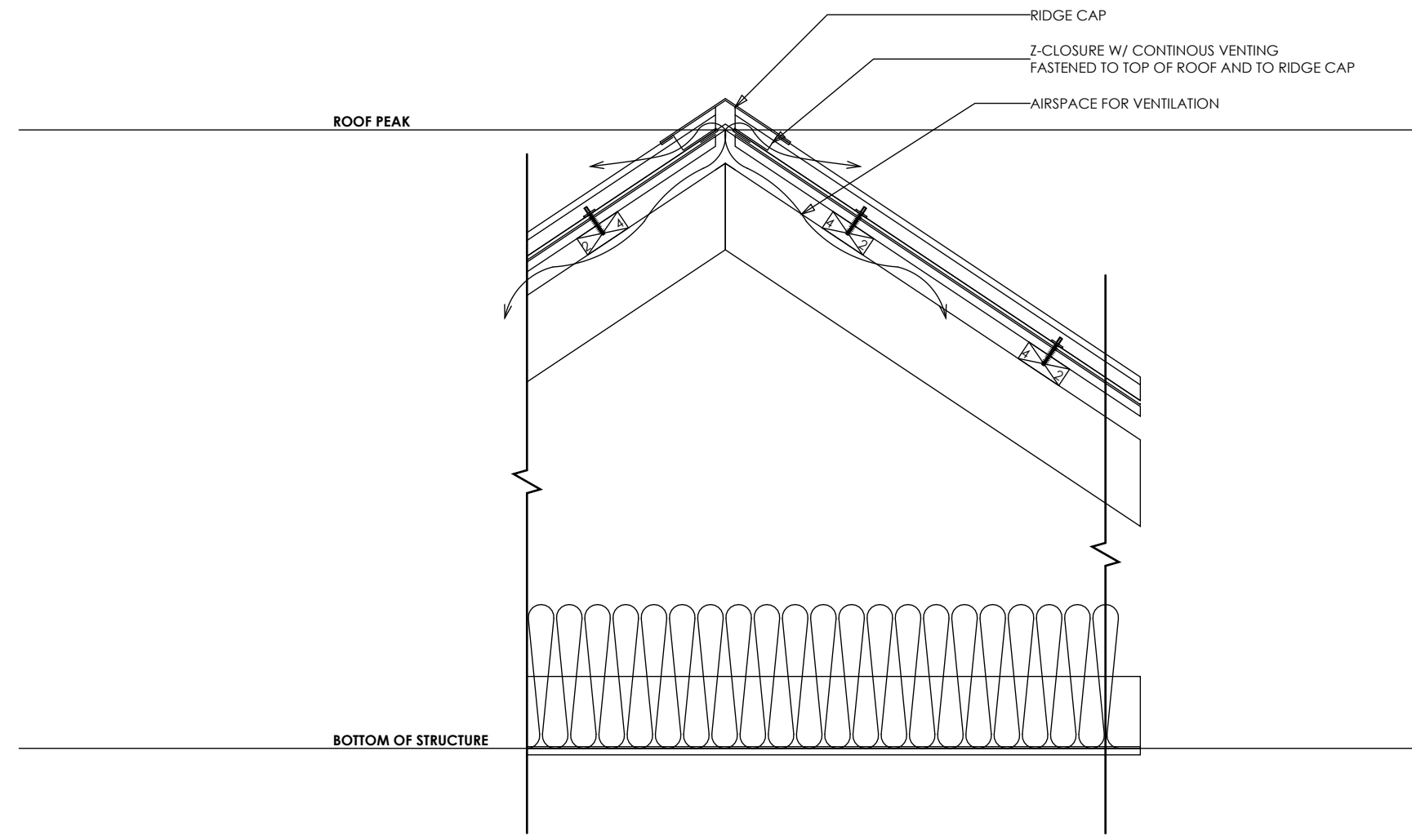

8 RIDGE VENTING - TRUSS
1" = 1'-0"

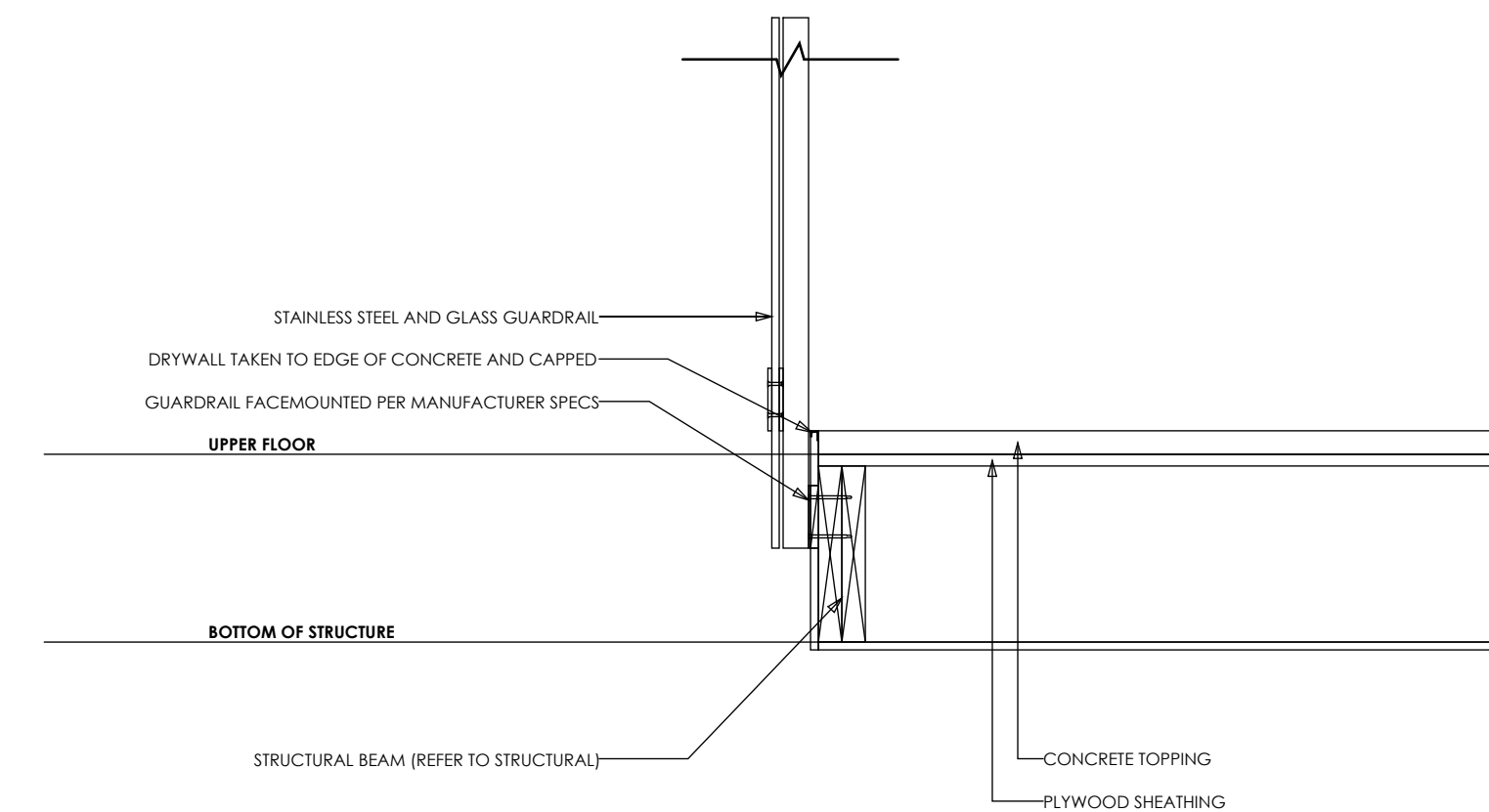

10 GUARDRAIL
1" = 1'-0"

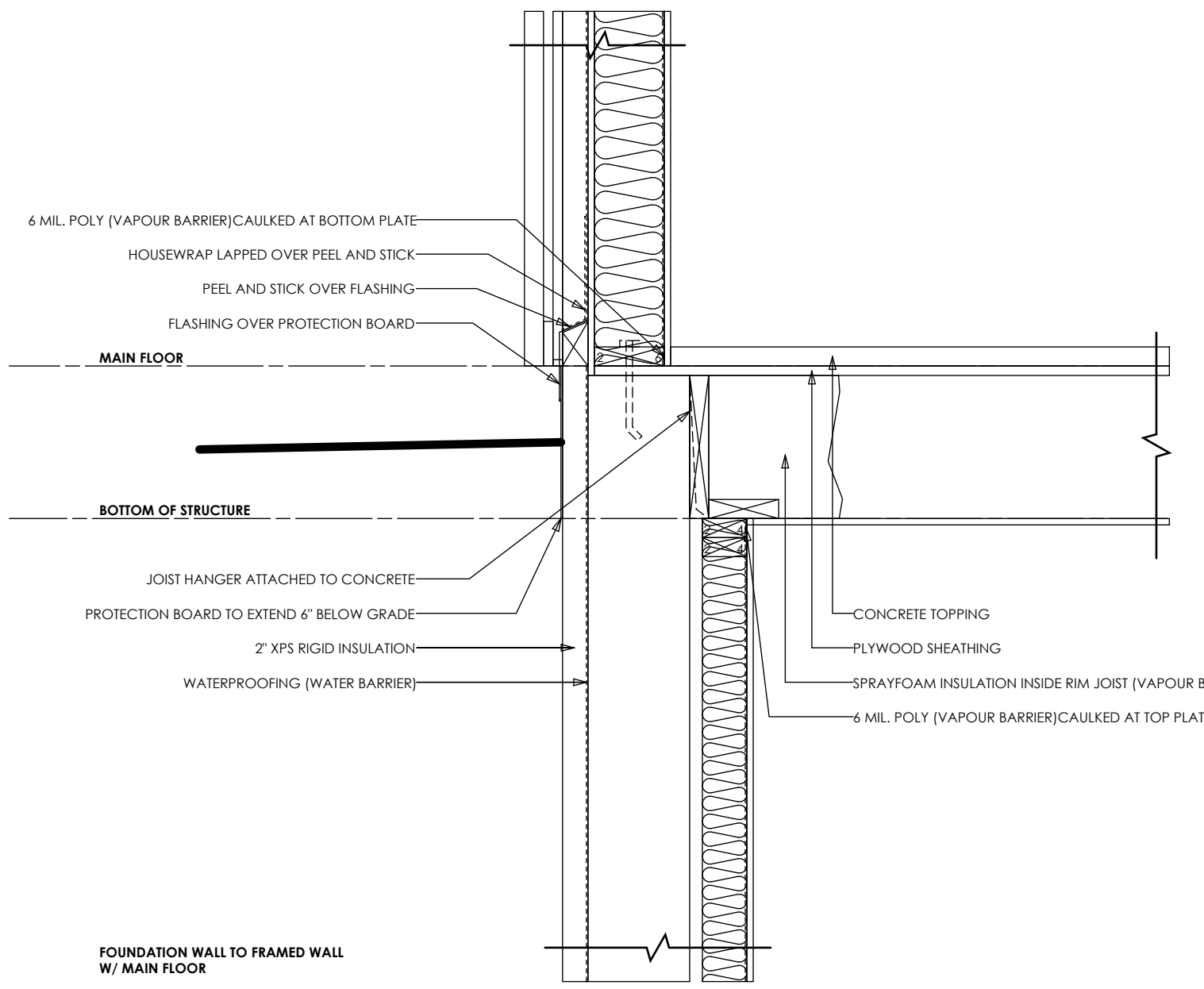

5 FOUNDATION TO MAIN
1" = 1'-0"

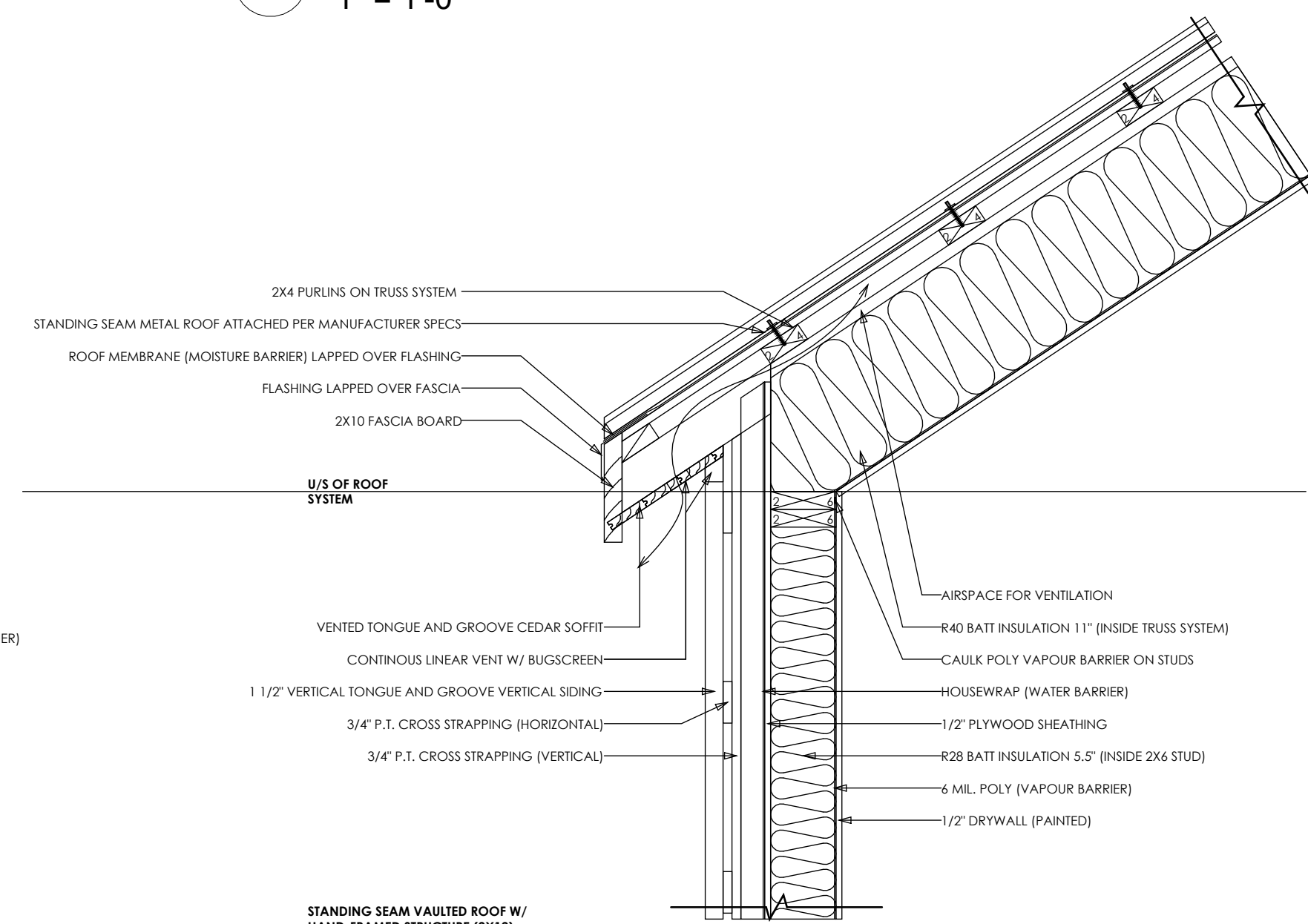

7 2ND TO ROOF
1" = 1'-0"

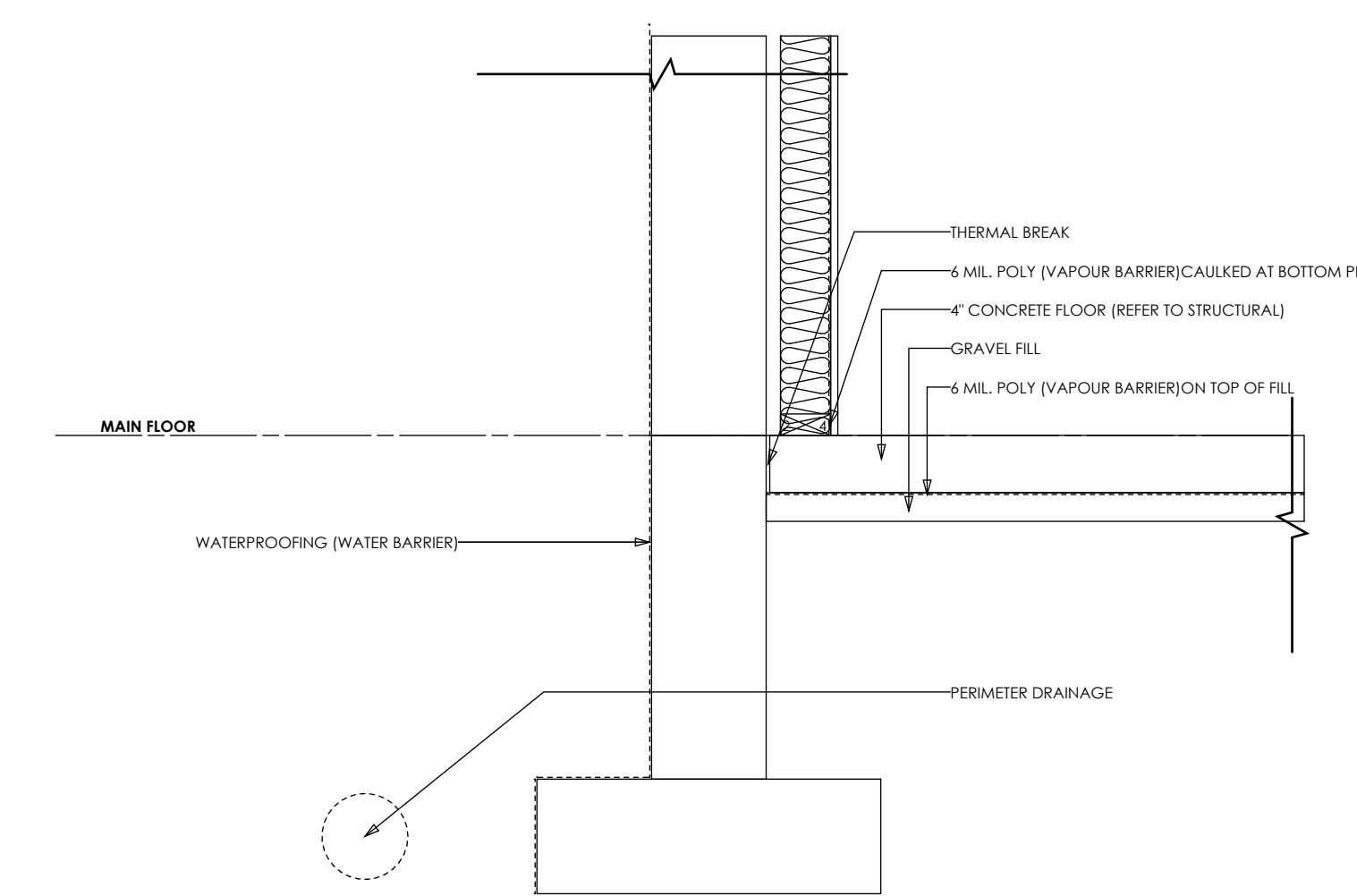

4 FOOTING TO FOUNDATION
1" = 1'-0"

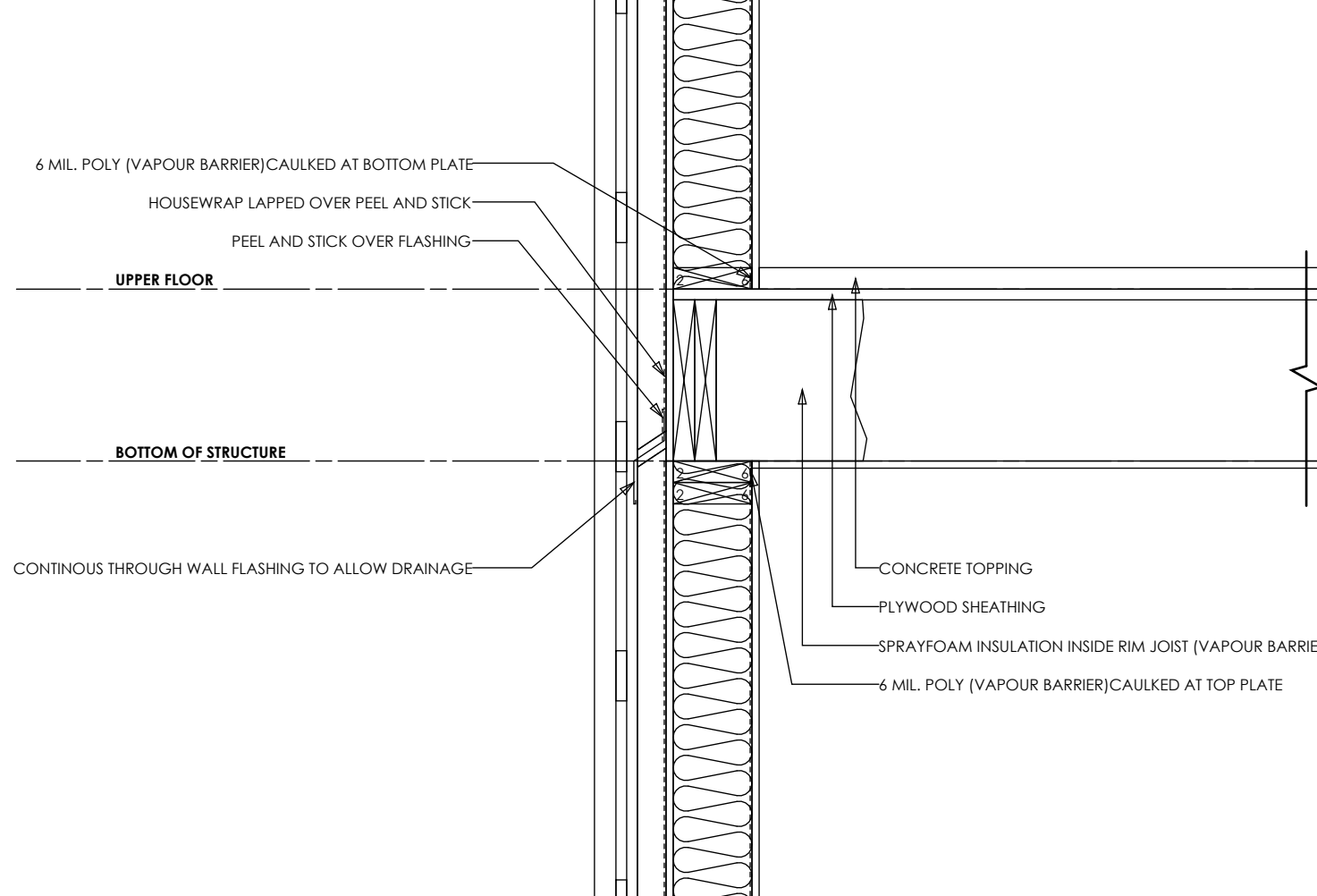

6 MAIN TO 2ND
1" = 1'-0"

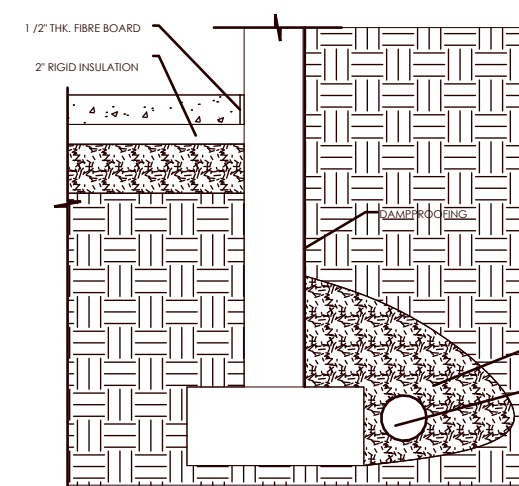

2 FOUNDATION

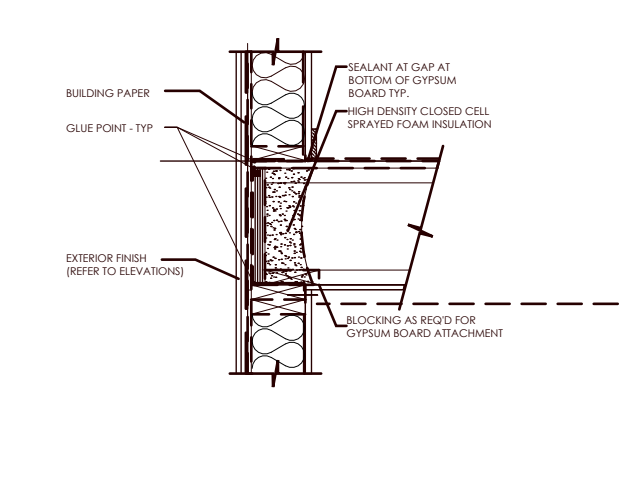

3 FLOOR JOIST

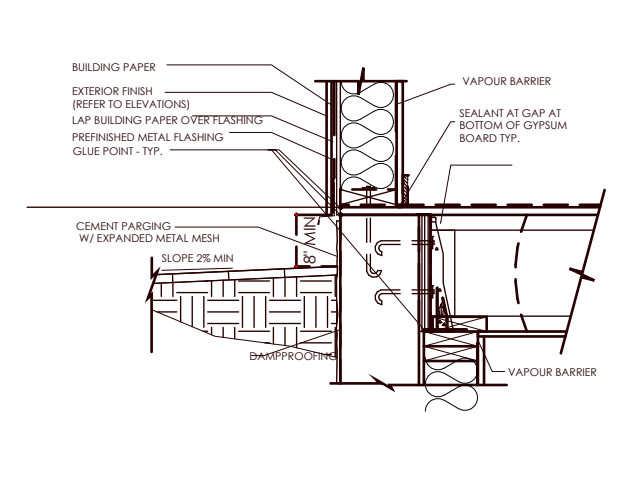

4 FLOOR JOIST

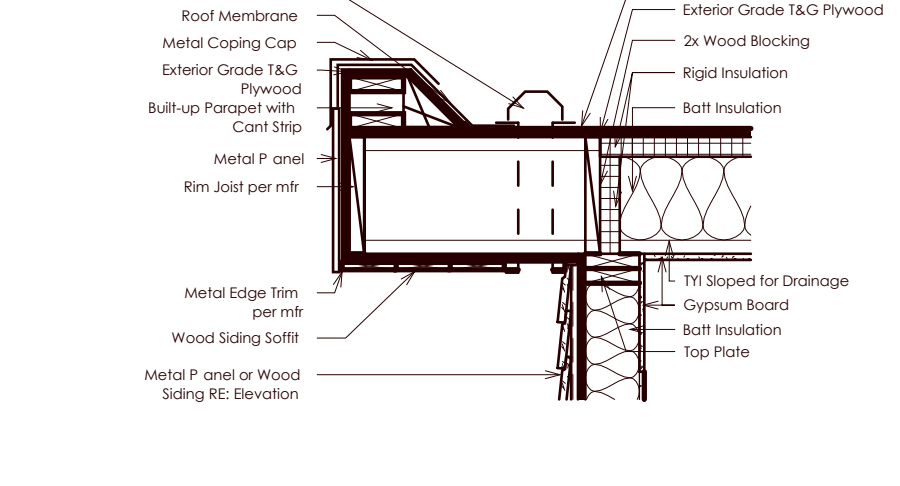

5 FLAT ROOF O.H

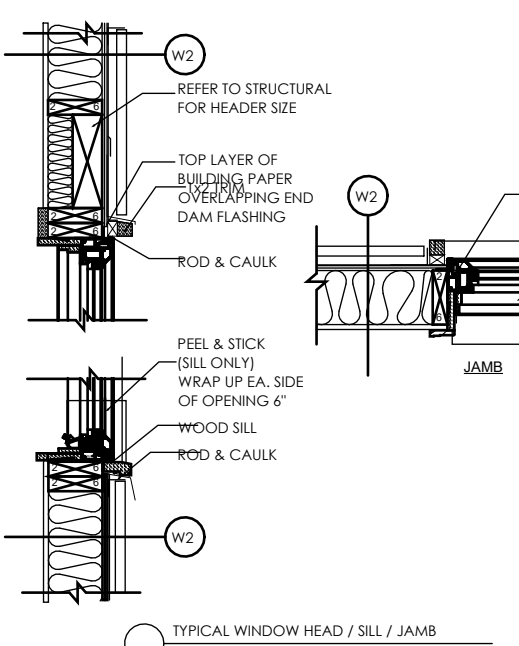

TYPICAL WINDOW HEAD / SILL / JAMB
SCALE 1" = 8"

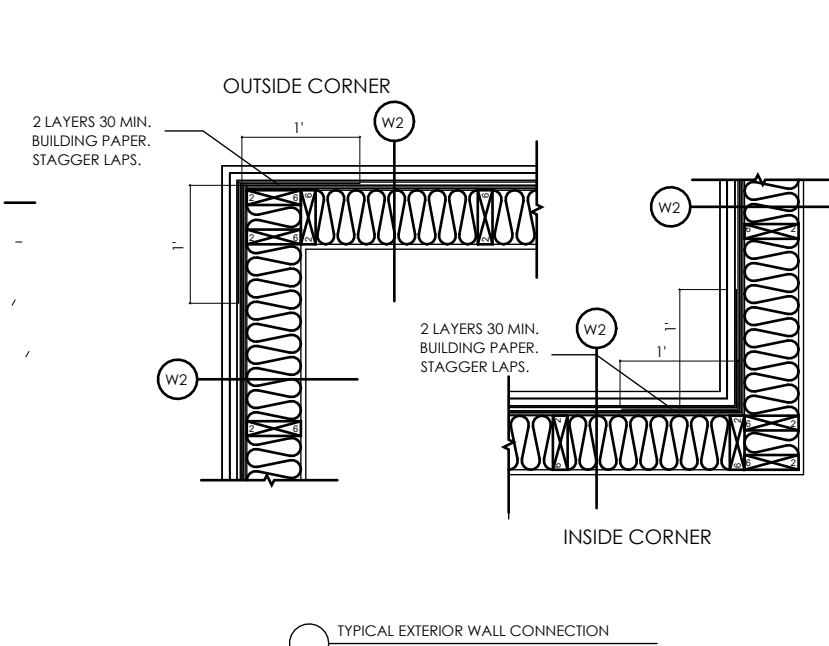

TYPICAL EXTERIOR WALL CONNECTION
SCALE 1" = 8"

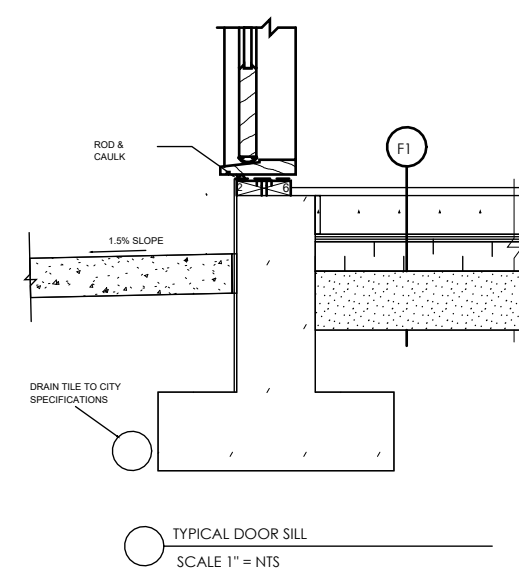

TYPICAL DOOR SILL
SCALE 1" = 8"

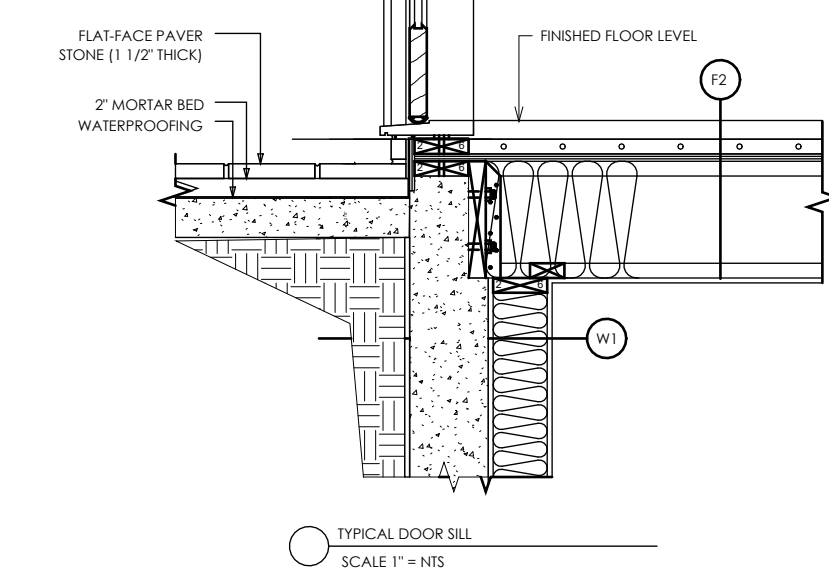

TYPICAL DOOR SILL
SCALE 1" = 8"

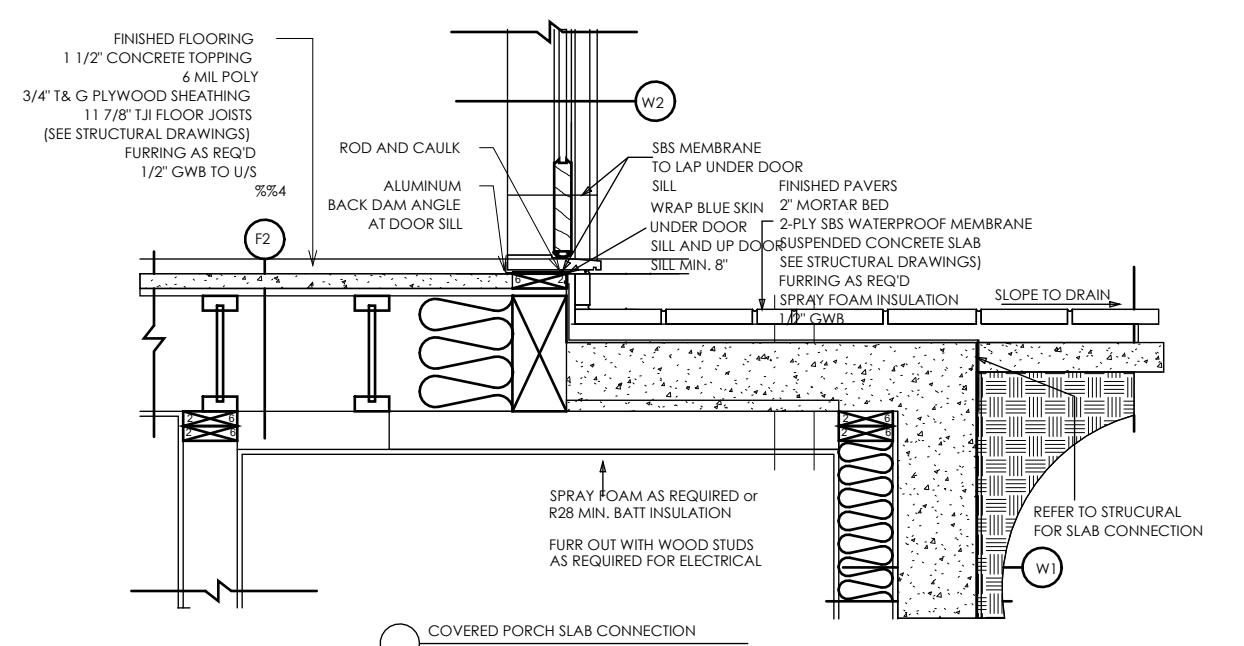

COVERED PORCH SLAB CONNECTION
SCALE 1" = 8"

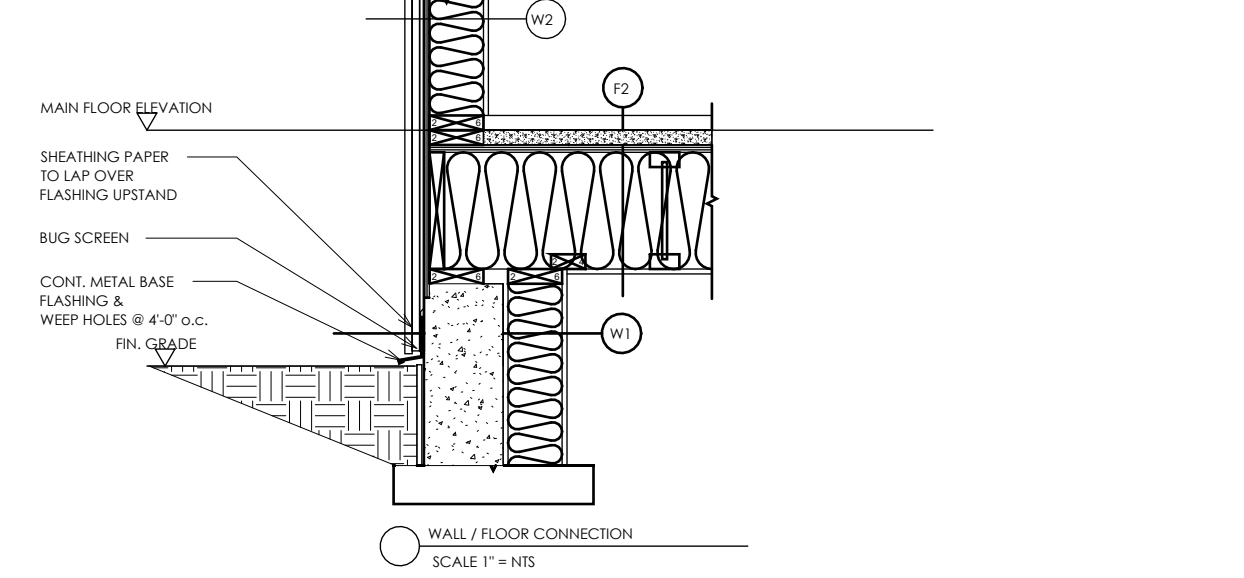

WALL / FLOOR CONNECTION
SCALE 1" = 8"

REVISIONS	
ISSUED FOR:	IFR
REVIEW SET:	02/03/22

PROJECT:
LOT A
652 EAST 4TH ST.
NORTH VANCOUVER

SHEET:

A110

DRAWN BY:

JP

24X36 SCALE:

As indicated

PROJECT NUMBER:

Project Number

START DATE:

05.03.23

DRAWING TITLE:
DETAILS

COPYRIGHT RESERVED.
THIS DRAWING AND DESIGN ARE AND SHALL AT ALL TIMES REMAIN THE EXCLUSIVE PROPERTY OF ROBERT BLANEY DESIGN AND CANNOT BE USED OR REPRODUCED WITHOUT WRITTEN CONSENT. WRITTEN DIMENSIONS SHALL HAVE PRECEDENCE OVER SCALED DIMENSIONS. CONTRACTOR SHALL VERIFY AND SHALL BE RESPONSIBLE FOR ALL DIMENSIONS AND CONDITIONS ON THE JOB AND THIS OFFICE SHALL BE INFORMED OF ANY VARIATIONS FROM THE DIMENSIONS AND CONDITIONS AS SHOWN ON THIS DRAWING. CONTRACTORS SHALL ENSURE THAT ALL CONSTRUCTION WILL COMPLY TO ALL APPLICABLE BUILDING CODES. ROBERT BLANEY DESIGN WILL NOT ACCEPT RESPONSIBILITY FOR VARIATIONS OR MODIFICATION OF THESE PLANS.



5464 PATRICIA BAY HIGHWAY,
VICTORIA BC V8Y 2N9

(604) 626-6020
ROBERTBLANEYDESIGN@GMAIL.COM
WWW.ROBERTBLANEYDESIGN.COM

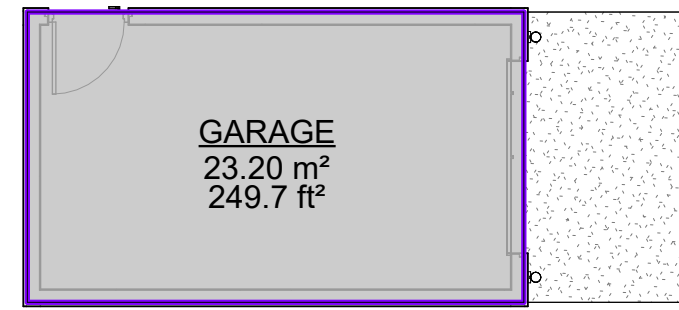
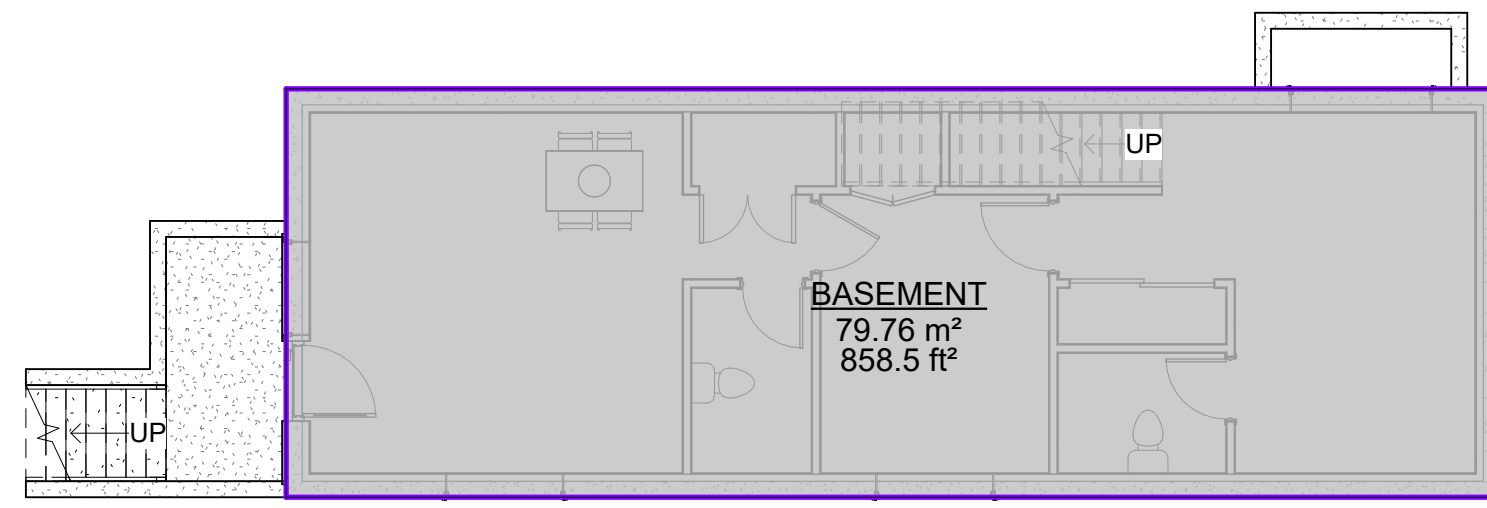

Area Schedule (Gross Building)			
Name	Area	Level	Perimeter
MAIN	839 ft²	MAIN FLOOR	135' - 0"
2ND	868 ft²	2ND FLOOR	139' - 0"
BASEMENT	859 ft²	BASEMENT	135' - 0"
GARAGE	250 ft²	GARAGE SLAB	65' - 6"
	2816 ft²		

3 BASEMENT
1/8" = 1'-0"

4 GARAGE
1/8" = 1'-0"

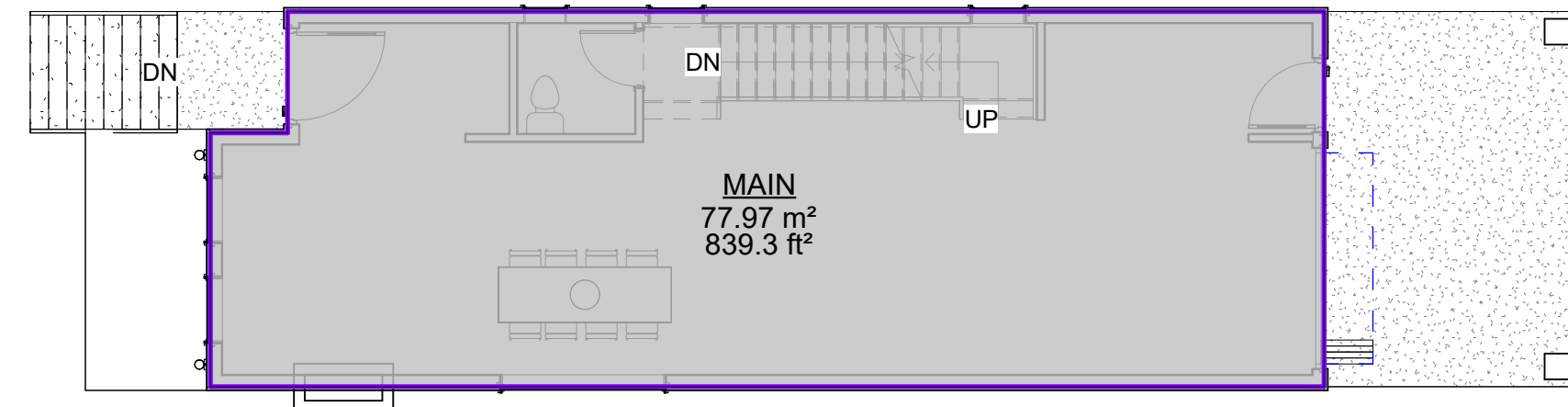

1 MAIN FLOOR
1/8" = 1'-0"

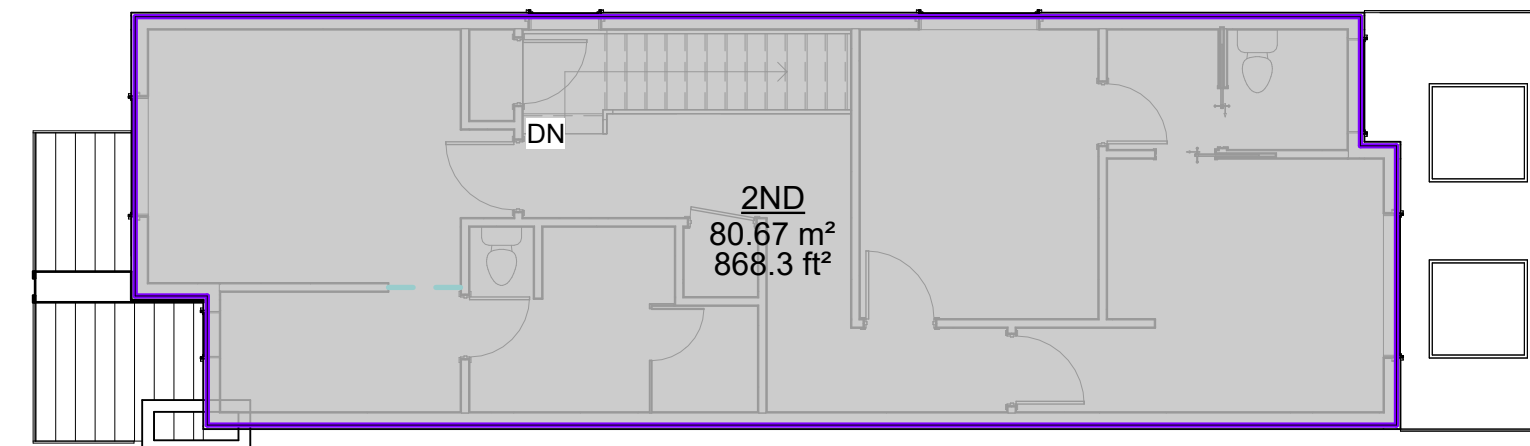

2 2ND FLOOR
1/8" = 1'-0"



5464 PATRICIA BAY HIGHWAY,
VICTORIA BC V8Y 2N9

(604) 626-6020
ROBERTBLANEYDESIGN@GMAIL.COM
WWW.ROBERTBLANEYDESIGN.COM

REVISIONS
ISSUED FOR: IFR
REVIEW SET: 08/11/22

PROJECT:
LOT A
652 EAST 4TH ST.
NORTH VANCOUVER

DRAWING TITLE:
F.A.R

SHEET:
A111

DRAWN BY: JP

24X36 SCALE: 1/8" = 1'-0"

PROJECT NUMBER: Project Number

START DATE: 05.03.23

COPYRIGHT RESERVED.
THIS DRAWING AND DESIGN ARE AND SHALL AT ALL TIMES REMAIN THE EXCLUSIVE PROPERTY OF ROBERT BLANEY DESIGN AND CANNOT BE USED OR REPRODUCED WITHOUT WRITTEN CONSENT. WRITTEN DIMENSIONS SHALL HAVE PRECEDENCE OVER SCALED DIMENSIONS. CONTRACTOR SHALL VERIFY AND SHALL BE RESPONSIBLE FOR ALL DIMENSIONS AND CONDITIONS ON THE JOB AND THIS OFFICE SHALL BE INFORMED OF ANY VARIATIONS FROM THE DIMENSIONS AND CONDITIONS AS SHOWN ON THIS DRAWING. CONTRACTORS SHALL ENSURE THAT ALL CONSTRUCTION WILL COMPLY TO ALL APPLICABLE BUILDING CODES. ROBERT BLANEY DESIGN WILL NOT ACCEPT RESPONSIBILITY FOR VARIATIONS OR MODIFICATION OF THESE PLANS.

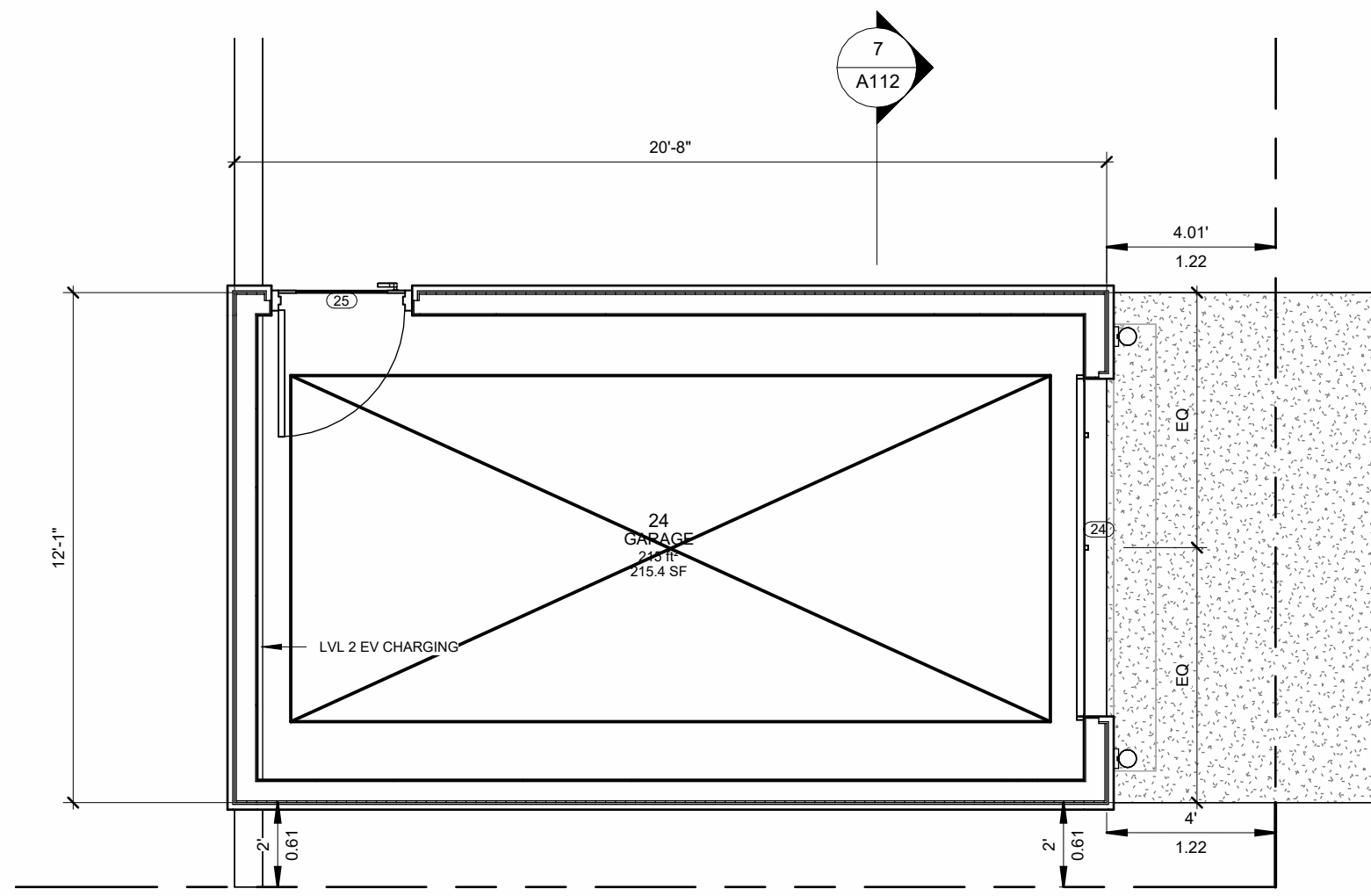

1 GARAGE FLOOR PLAN
1/4" = 1'-0"

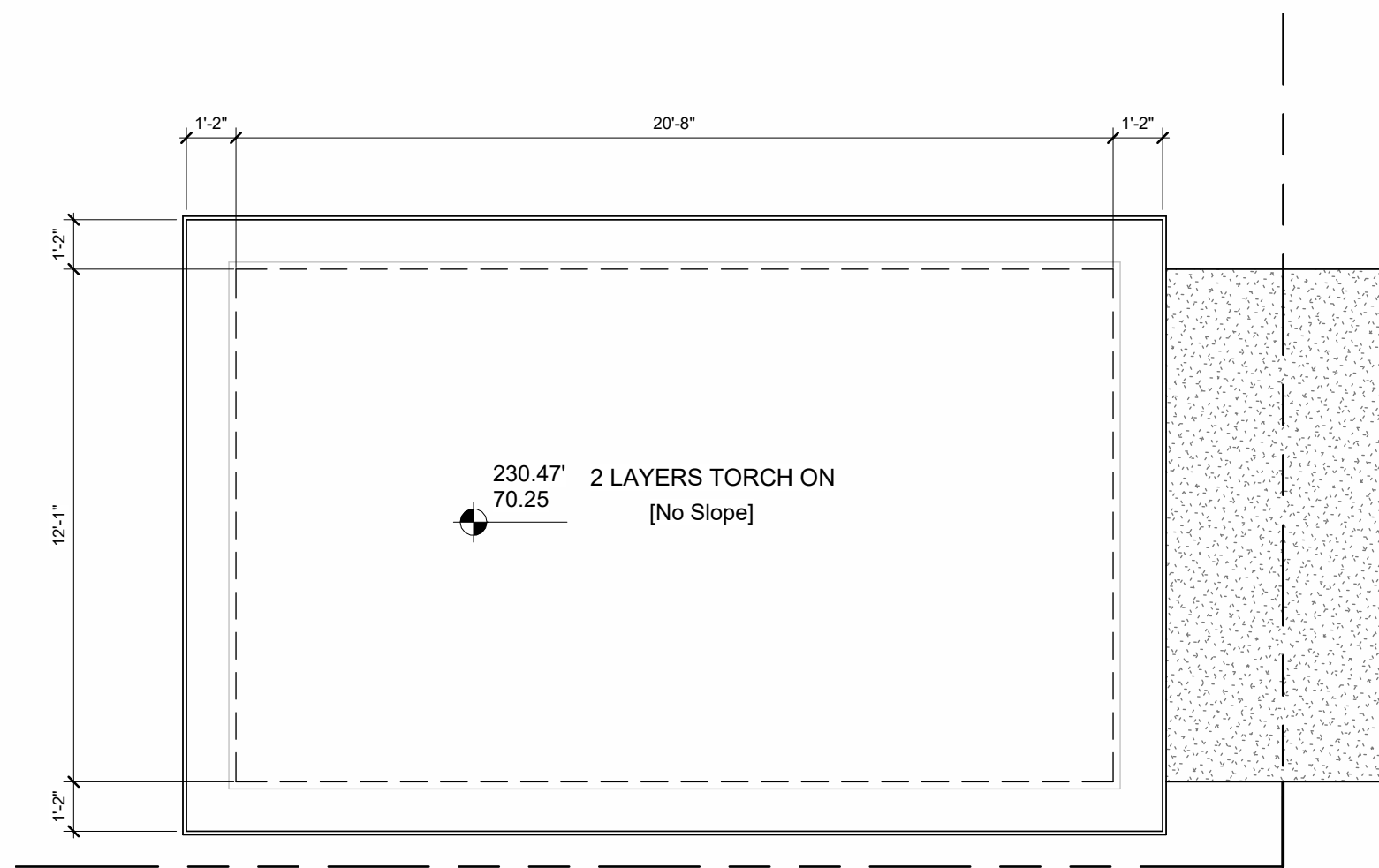

2 GARAGE ROOF PLAN
1/4" = 1'-0"

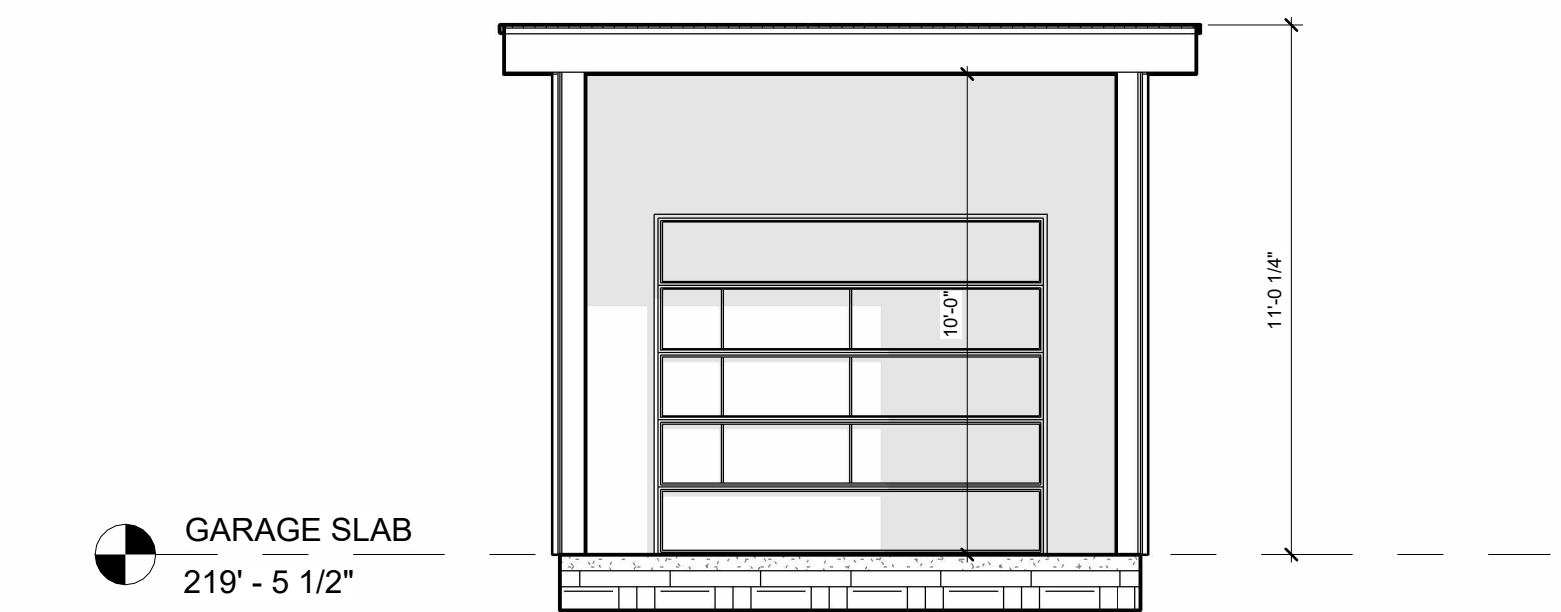

7 GARAGE SECTION
1/4" = 1'-0"

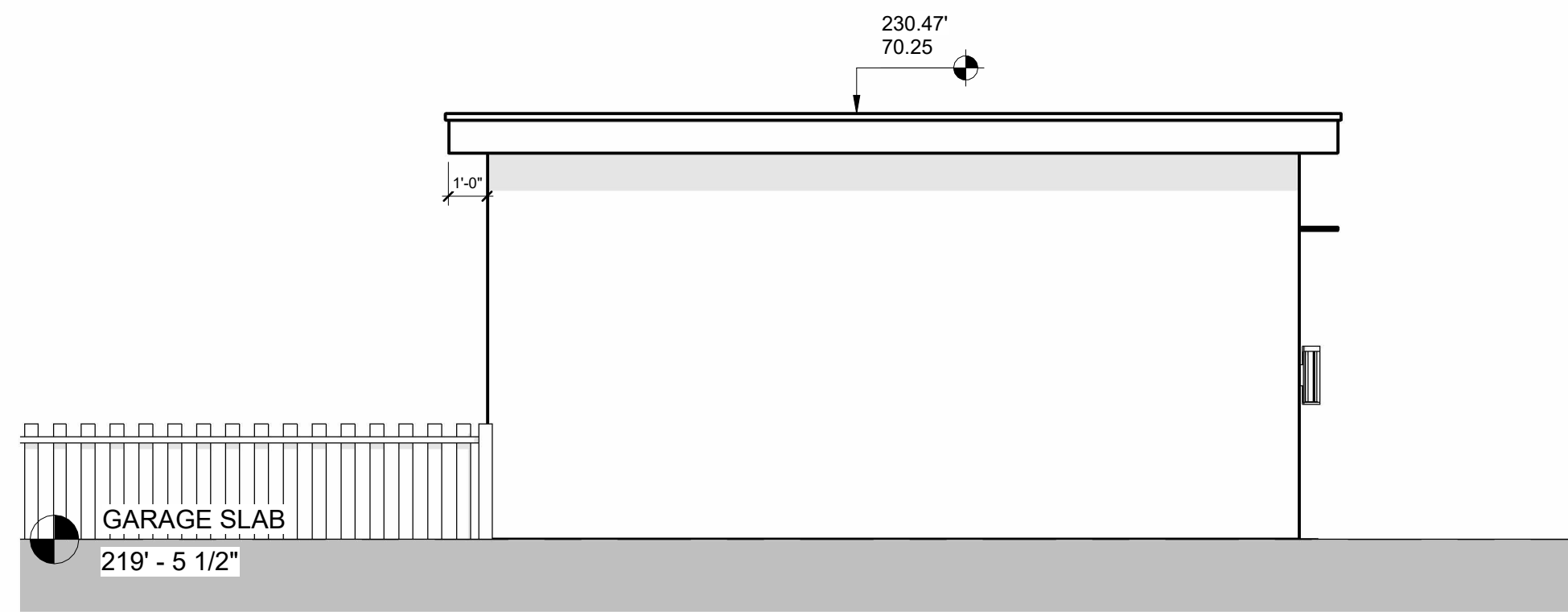

3 GARAGE EAST
1/4" = 1'-0"

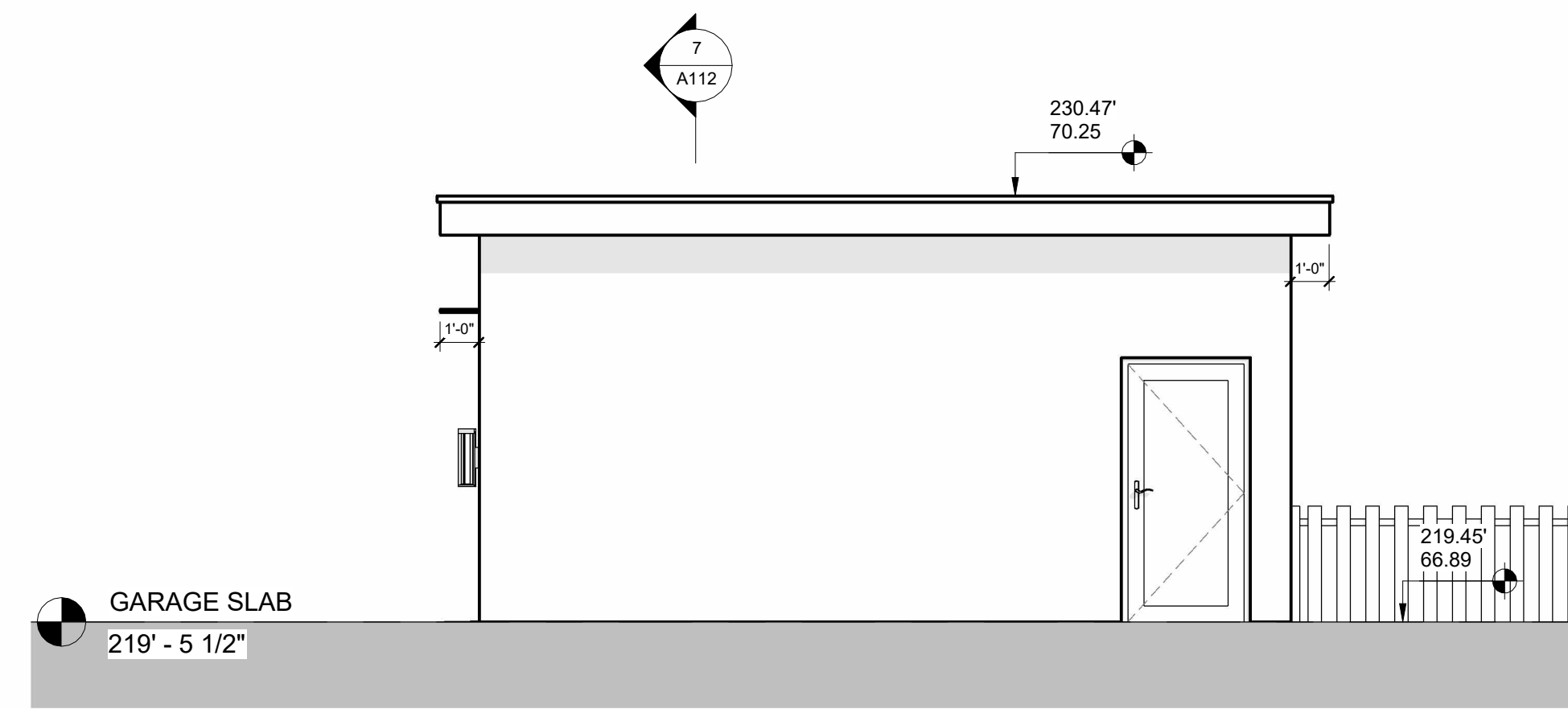

6 GARAGE WEST
1/4" = 1'-0"

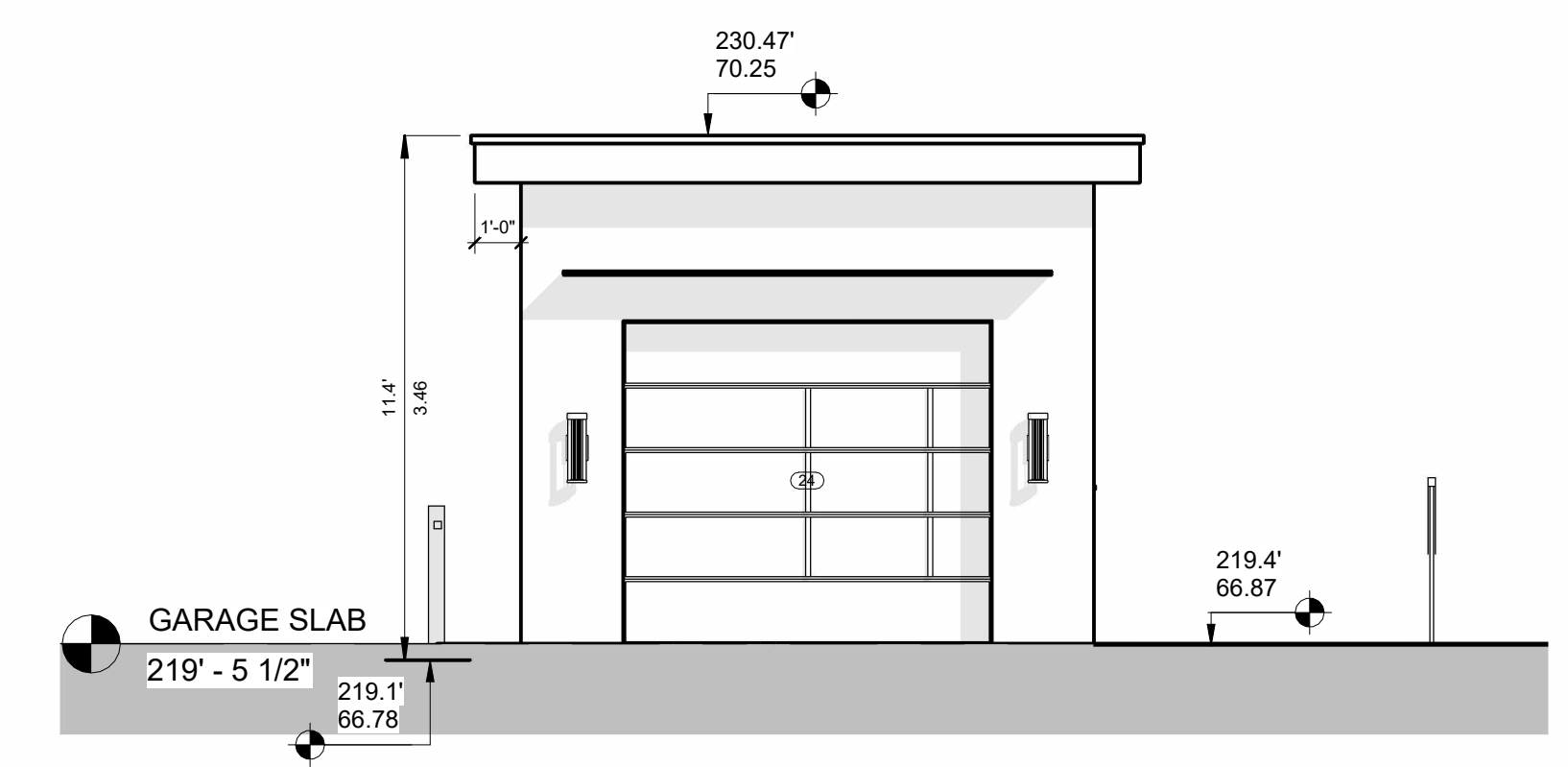

4 GARAGE NORTH
1/4" = 1'-0"

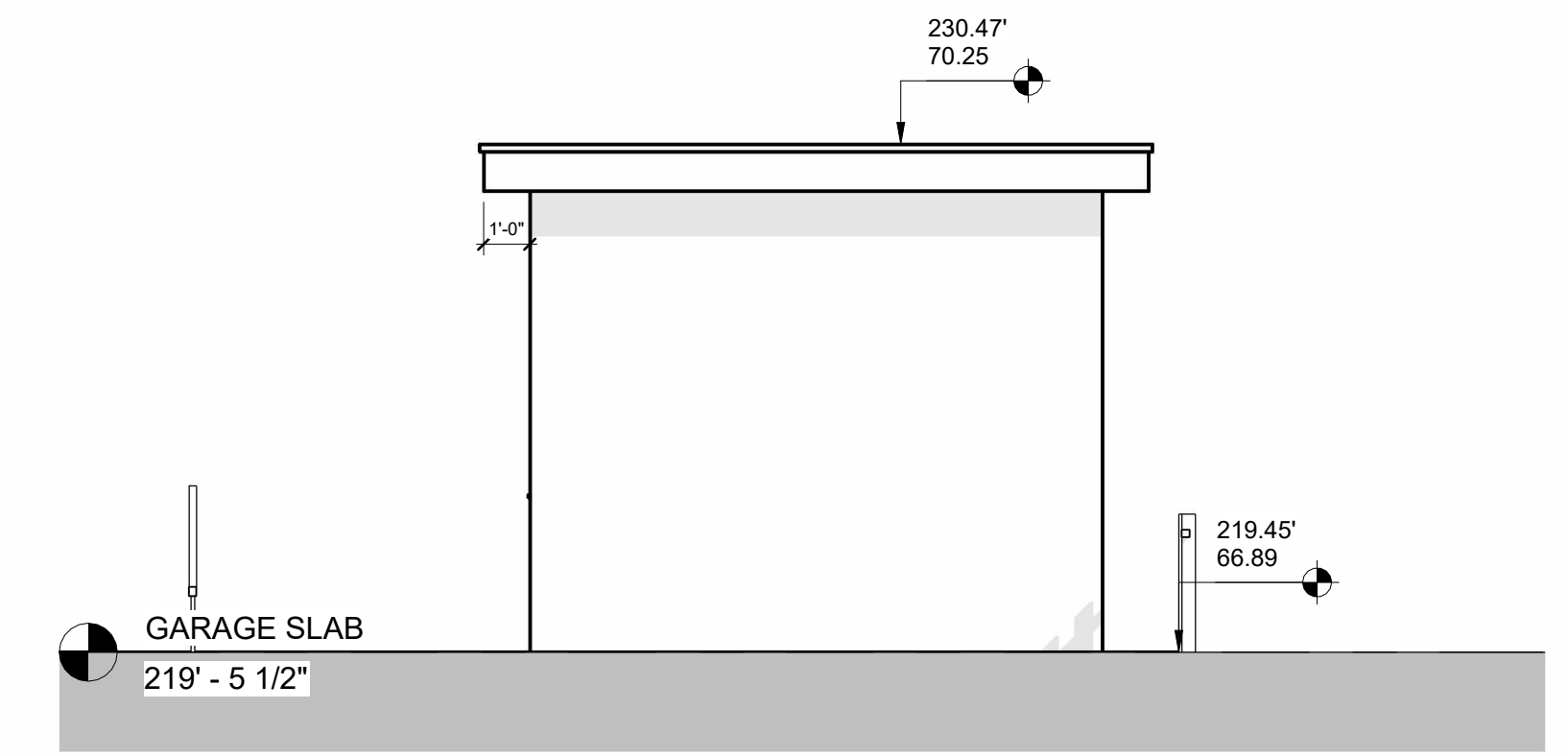

5 GARAGE SOUTH
1/4" = 1'-0"



5464 PATRICIA BAY HIGHWAY,
VICTORIA BC V8Y 2N9

(604) 626-6020
ROBERTBLANEYDESIGN@GMAIL.COM
WWW.ROBERTBLANEYDESIGN.COM

REVISIONS
ISSUED FOR: IFR
REVIEW SET: 05/17/23

PROJECT:
LOT A
652 EAST 4TH ST.
NORTH VANCOUVER

DRAWING TITLE:
GARAGE

SHEET:

A112

DRAWN BY:
JP

24X36 SCALE:
1/4" = 1'-0"

START DATE:
05.03.23

PROJECT NUMBER:
Project Number

COPYRIGHT RESERVED.

THIS DRAWING AND DESIGN ARE AND SHALL AT ALL TIMES REMAIN THE EXCLUSIVE PROPERTY OF ROBERT BLANEY DESIGN AND CANNOT BE USED OR REPRODUCED WITHOUT WRITTEN CONSENT. WRITTEN DIMENSIONS SHALL HAVE PRECEDENCE OVER SCALED DIMENSIONS. CONTRACTOR SHALL VERIFY AND SHALL BE RESPONSIBLE FOR ALL DIMENSIONS AND CONDITIONS ON THE JOB AND THIS OFFICE SHALL BE INFORMED OF ANY VARIATIONS FROM THE DIMENSIONS AND CONDITIONS AS SHOWN ON THIS DRAWING. CONTRACTORS SHALL ENSURE THAT ALL CONSTRUCTION WILL COMPLY TO ALL APPLICABLE BUILDING CODES. ROBERT BLANEY DESIGN WILL NOT ACCEPT RESPONSIBILITY FOR VARIATIONS OR MODIFICATION OF THESE PLANS.